

TC25

Rugged Smartphone



User Guide for Android™ 8.1.0 Oreo



ZEBRA

Copyright

ZEBRA and the stylized Zebra head are trademarks of Zebra Technologies Corporation, registered in many jurisdictions worldwide. Google, Android, Google Play and other marks are trademarks of Google LLC; Oreo is a trademark of Mondelez International, Inc. group. All other trademarks are the property of their respective owners. ©2019 Zebra Technologies Corporation and/or its affiliates. All rights reserved.

COPYRIGHTS & TRADEMARKS: For complete copyright and trademark information, go to www.zebra.com/copyright.

WARRANTY: For complete warranty information, go to www.zebra.com/warranty.

END USER LICENSE AGREEMENT: For complete EULA information, go to www.zebra.com/eula.

Terms of Use

- Proprietary Statement

This manual contains proprietary information of Zebra Technologies Corporation and its subsidiaries (“Zebra Technologies”). It is intended solely for the information and use of parties operating and maintaining the equipment described herein. Such proprietary information may not be used, reproduced, or disclosed to any other parties for any other purpose without the express, written permission of Zebra Technologies.

- Product Improvements

Continuous improvement of products is a policy of Zebra Technologies. All specifications and designs are subject to change without notice.

- Liability Disclaimer

Zebra Technologies takes steps to ensure that its published Engineering specifications and manuals are correct; however, errors do occur. Zebra Technologies reserves the right to correct any such errors and disclaims liability resulting therefrom.

- Limitation of Liability

In no event shall Zebra Technologies or anyone else involved in the creation, production, or delivery of the accompanying product (including hardware and software) be liable for any damages whatsoever (including, without limitation, consequential damages including loss of business profits, business interruption, or loss of business information) arising out of the use of, the results of use of, or inability to use such product, even if Zebra Technologies has been advised of the possibility of such damages. Some jurisdictions do not allow the exclusion or limitation of incidental or consequential damages, so the above limitation or exclusion may not apply to you.

Revision History

Changes to the original guide are listed below:

Change	Date	Description
-01 Rev A	3/2018	Initial Release

Table of Contents

Copyright	2
Terms of Use	2
Revision History	2
Table of Contents.....	3
About This Guide.....	11
Configurations	11
Chapter Descriptions	11
Notational Conventions	12
Related Documents and Software	12
Service Information	12
Provide Documentation Feedback	13
Getting Started.....	14
Unpacking	14
Features	15
Setup	17
Installing a microSD Card	17
Installing the SIM Card	19
Charging the Battery	20
Charging Indicators	22
Google Account Setup	23
Zebra Visibility Services	23
Replacing the microSD Card	24
Replacing the SIM Card	26
Accessing Device Settings	27
Battery Management	27
Monitoring Battery Usage	28

Table of Contents

Low Battery Notification	28
Battery Optimization	29
Turning Off the Radios	29
Setting the Date and Time	29
Display Settings	30
Setting the Screen Brightness	30
Setting Screen Rotation	30
Setting Screen Timeout	30
Setting Font Size	31
Setting Screen Rotation	32
Setting Display Size	32
Setting the Charge LED	32
General Sound Setting	33
Using the Device	35
Google Mobile Services	35
Home Screen	35
Home Screen	36
Setting Home Screen Rotation	37
Status Bar	37
Status Icons	37
Notification Icons	39
Managing Notifications	40
Setting App Notifications	40
Viewing Notification Settings for All Apps	41
Controlling Lock Screen Notifications	41
Quick Access Panel	41
Editing Icons on Quick Settings	42
App Shortcuts and Widgets	43
Adding an App Shortcut to the Home Screen	43
Adding a Widget to the Home Screen	43
Moving Items on the Home Screen	44
Removing an App Shortcut or Widget from the Home Screen	44
Folders	44
Creating a Folder	44
Naming Folders	44
Removing a Folder	45
Home Screen Wallpaper	45
Using the Touchscreen	45
On-Screen Keyboards	45
Editing Text	46
Entering Numbers, Symbols and Special Characters	46

Table of Contents

Hiding On-Screen Keyboard	46
Switching Language Keyboards	46
Configuring the Keyboard	47
AOSP Keyboard	47
GMS Keyboard	47
Do Not Disturb Feature	47
Limit Sounds and Vibrations	47
Total Silence	48
Alarms Only	48
Priority Notifications Only	48
Automatically Block Sounds and Vibrations	49
Silence Sounds During Certain Times	49
Silence Sounds During Events and Meetings	49
Turn Sounds Back On	50
Override Do Not Disturb for Specific Apps	50
Apps	51
Accessing Apps	53
Switching Between Recent Apps	54
Un-Locking the Screen	55
Resetting the Device	57
Performing a Soft Reset	57
Performing a Hard Reset	57
Suspend Mode	58
Transferring Files with a Host Computer via USB	58
Transferring Files	58
Transferring Photos	59
Disconnect from the Host Computer	59
Calls	60
Introduction	60
Emergency Calling	60
Audio Modes	60
Using a Bluetooth Headset	60
Adjusting Audio Volume	60
Making a Call Using the Dialer	61
Dialer Dialing Options	62
Making a Call Using Contacts	62
Using the Dialer	63
Using the Contacts App	63
Making a Conference Call on GSM	65
Making a Conference Call on GSM	67

Table of Contents

Making a Call Using a Bluetooth Headset	70
Answering Calls	70
Call Settings	71
Applications	73
Camera	74
Taking Photos	74
Taking a Panoramic Photo	75
Recording Videos	75
Photo Settings	76
Rear Camera	77
Video Settings	77
Rear Camera	78
Contacts	78
Adding a Contact	78
Editing Contacts	78
Deleting Contacts	79
DataWedge Demonstration	80
Scanner Selection	81
Diagnostic Tool	81
Settings	84
Battery Test Information	84
GPS Test Information	85
System Test Information	85
WLAN Test Information	85
WWAN Test Information	85
Bluetooth Test Information	86
Files	87
Gallery	88
Working with Albums	89
Sharing an Album	90
Getting Album Information	90
Deleting an Album	90
Working with Photos	91
Cropping a Photo	91
Setting a Photo as a Contact Icon	91
Sharing a Photo	92
Deleting a Photo	92
Working with Videos	92
Watching Videos	92
Sharing a Video	92
Deleting a Video	93

Table of Contents

Photos	94
Working with Albums	95
Deleting an Album	96
Working with Photos	96
Viewing and Browsing Photos	96
Cropping a Photo	97
Setting a Photo as a Contact Icon	98
Sharing a Photo	98
Deleting a Photo	99
Working with Videos	99
Watching a Video	99
Sharing a Video	99
Deleting a Video	99
PTT Express Voice Client	100
PTT Audible Indicators	100
PTT Notification Icons	100
Enabling PTT Communication	101
Selecting a Talk Group	101
PTT Communication	101
Creating a Group Call	102
Responding with a Private Response	102
Disabling PTT Express Voice Client Communication	102
RxLogger	102
Enabling Logging	104
RxLogger Utility	105
Sound Recorder	105
Data Capture.....	107
Imaging	107
Operational Modes	107
RS507/RS507x Hands-Free Imager	108
RS6000 Bluetooth Ring Scanner	109
Scanning Considerations	109
Barcode Scanning with Internal SE2100 Imager	109
SE2100 Picklist Mode	110
SE2100 Basic MultiBarcode Mode	111
Barcode Scanning with Internal SE4710 Imager	112
SE4710 Basic MultiBarcode Mode	113
Scanning with RS6000 Bluetooth Ring Scanner	114
Scanning with RS507/RS507X Hands-Free Imager	115
Pairing the RS507/RS507X/RS6000 Hands-Free Imager	117
Pairing Using Simple Serial Interface	117
Pairing Using Bluetooth Human Interface Device	117

Table of Contents

DataWedge	119
Enabling DataWedge	119
Disabling DataWedge	119
Wireless	120
Wireless Wide Area Networks	120
Sharing the Mobile Data Connection	120
Enabling USB Tethering	120
Enabling Bluetooth Tethering	121
Enabling Wi-Fi Hotspot	121
Configuring the Wi-Fi Hotspot	121
Cellular Network Settings	122
Disabling Data When Roaming	122
Enhanced 4G LTE Mode	122
Indonesian configurations do not support LTE.	122
Using Search for MicroCell	122
Configuring the Access Point Name	122
Locking the SIM Card	123
Data Usage	123
Setting Data Usage Warning	124
Setting Data Limit	124
Wireless Local Area Networks	124
Connecting to a Wi-Fi Network	125
Removing a Wi-Fi Network	126
Bluetooth	126
Adaptive Frequency Hopping	127
Security	127
Bluetooth Profiles	128
Bluetooth Power States	129
Bluetooth Radio Power	129
Enabling Bluetooth	129
Disabling Bluetooth	129
Discovering Bluetooth Device(s)	130
Changing the Bluetooth Name	130
Connecting to a Bluetooth Device	130
Selecting Profiles on the Bluetooth Device	130
Unpairing a Bluetooth Device	131
Accessories	132
Accessories	132
1-Slot Base Charge Only Cradle	134
Charging the Device	135

Table of Contents

Battery Charging	136
Charging Temperature	136
1-Slot Ethernet Cradle	137
USB/Ethernet Communication	137
Ethernet LED Indicators	138
Establishing Ethernet Connection	139
Charging the Device	139
Battery Charging	140
Charging Temperature	140
5-Slot Charge Only Cradle	141
Charging the TC20	141
Battery Charging	142
Charging Temperature	142
Extended Power Pack	143
Installation	143
Charging	143
Power Pack Charging	145
Charging Temperature	146
Check Power Level	146
Resetting the Extended Power Pack	147
Trigger Handle	148
Installing the Optional Lanyard	148
Inserting the Device into the Trigger Handle	149
Removing the Device from the Trigger Handle	150
Wrist/Arm Mount	152
Wrist/Arm Mount Installation	152
Device Installation	153
Device Removal	155
Scanning	155
Strap Installation	156
Hand Strap	158
Soft Holster	161
Adjusting the Holster	161
Maintenance and Troubleshooting	164
Maintaining the TC25	164
Display Best Practices	164
Image Retention	164
Long-Term Storage	164
Cleaning Instructions	165
Approved Cleanser Active Ingredients	165
Harmful Ingredients	165

Table of Contents

Cleaning Instructions	165
Special Cleaning Notes	165
Cleaning Materials Required	165
Cleaning Frequency	166
Cleaning the TC25	166
Housing	166
Display	166
Camera and Exit Window	166
Connector Cleaning	166
Cleaning Cradle Connectors	166
Troubleshooting	167
TC25	167
Technical Specifications	170
TC25	170
Index.....	174

About This Guide

This guide provides information about using the TC25 Rugged Smartphone and accessories.



NOTE: Screens and windows pictured in this guide are samples and can differ from actual screens. This guide applies to model numbers: TC25AJ, TC25BJ, and TC25CJ.

Configurations

This guide covers the following configurations:

Table 1 *Configurations*

Configuration	Radios	Operating System Android 8.1.0	Memory RAM/Flash	Data Capture	8 MP Camera	Access Door
TC25AJ-10B101xx	WAN/LAN/PAN	GMS	2 GB/16 GB	SE2100	Yes	Blank
TC25AJ-10C102xx	WAN/LAN/PAN	GMS	2 GB/16 GB	SE4710	No	2-Pin
TC25BJ-10B101xx	WAN/LAN/PAN	GMS	2 GB/16 GB	SE2100	Yes	Blank
TC25BJ-10C102xx	WAN/LAN/PAN	GMS	2 GB/16 GB	SE4710	No	2-Pin

NOTE: Indonesia configurations do not support LTE.

Chapter Descriptions

Topics covered in this guide are as follows:

- [Getting Started](#) provides information on getting the TC25 up and running for the first time.
- [Using the Device](#) provides information for operating the TC25.
- [Calls](#) provides instructions for making phone calls.
- [Applications](#) provides information on using applications installed on the TC25.
- [Data Capture](#) provides information on capture barcode data.
- [Wireless](#) provides information on the various wireless options.

- [Accessories](#) provides information on using the accessories for the TC25.
- [Maintenance and Troubleshooting](#) includes instructions on cleaning and provides troubleshooting solutions for potential problems during TC25 operation.
- [Technical Specifications](#) provides the technical specifications for the TC25.

Notational Conventions

The following conventions are used in this document:

- **Bold** text is used to highlight the following:
 - Dialog box, window and screen names
 - Drop-down list and list box names
 - Check box and radio button names
 - Icons on a screen
 - Key names on a keypad
 - Button names on a screen.
- Bullets (•) indicate:
 - Action items
 - Lists of alternatives
 - Lists of required steps that are not necessarily sequential.
 - Sequential lists (e.g., those that describe step-by-step procedures) appear as numbered lists.

Related Documents and Software

The following documents provide more information about the TC25 rugged smartphone.

- TC25 Quick Reference Guide, p/n MN-003052-xx
- TC25 Regulatory Guide, p/n MN-003053-xx
- TC25 Rugged Smartphone Integrator Guide, p/n MN-003307-xx

For the latest version of this guide and all guides, go to: zebra.com/support.

Service Information

If you have a problem with your equipment, please use the Self-Help support resources available at www.zebra.com. If the support provided via the Self-Help resources is not sufficient, you may contact Zebra Global Customer Support for your region. Contact information is available at: zebra.com/support.

When contacting support, please have the following information available:

- Serial number of the unit
- Model number or product name
- Software type and version number.

Zebra responds to calls by email, telephone or fax within the time limits set forth in support agreements.

If your problem cannot be solved by Zebra Customer Support, you may need to return your equipment for servicing and will be given specific directions. Zebra is not responsible for any damages incurred during



shipment if the approved shipping container is not used. Shipping the units improperly can possibly void the warranty.

If you purchased your Zebra business product from a Zebra business partner, contact that business partner for support.

Provide Documentation Feedback

If you have comments, questions, or suggestions about this guide, send an email to EVM-Techdocs@zebra.com.

Getting Started

This chapter provides information for getting the device up and running for the first time.

Unpacking

Carefully remove all protective material from the device and save the shipping container for later storage and shipping.

1. Verify that the following were received:
 - touch computer
 - Regulatory Guide.
2. Inspect the equipment for damage. If any equipment is missing or damaged, contact the Global Customer Support center immediately.
3. Prior to using the device for the first time, remove the protective shipping film that covers the scan window, display and camera window.

Features

Figure 1 TC25 Front View

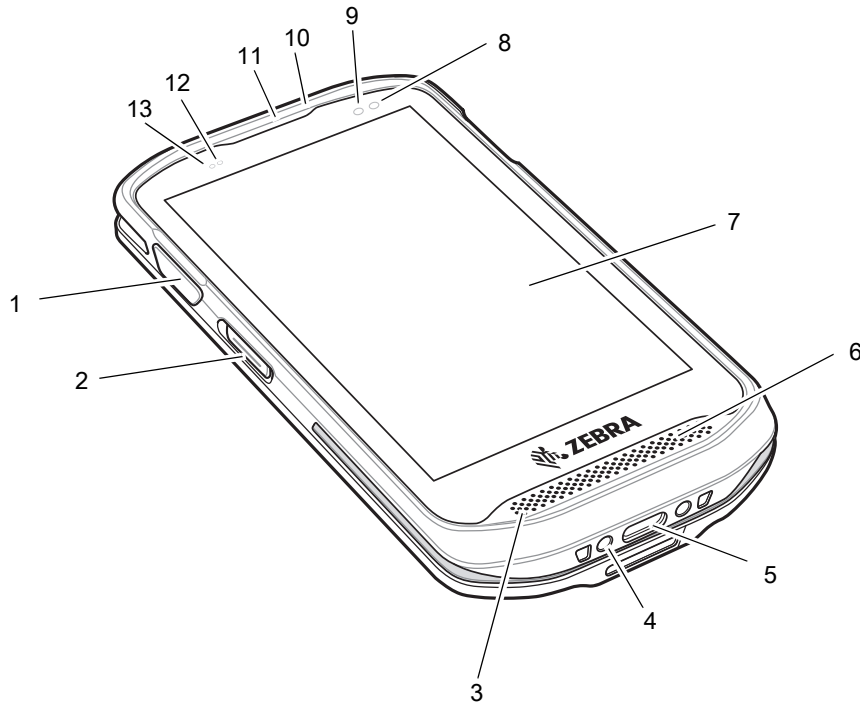

Table 2 Front View Features

Number	Item	Function
1	Scan Button	Initiates data capture (programmable). Yellow button: TC25 with SE4710 imager. Gray button: TC25 with SE2100 imager.
2	PTT Button	Initiates push-to-talk communications (programmable).
3	Microphone	Use for communications in Handset mode.
4	Power Contacts	Provides power for charging the TC25.
5	USB-C Connector	Provides USB host and client communications, and device charging via cables and accessories.
6	Speaker	Provides audio output for video and music playback. Provides audio in speakerphone mode.
7	Touch Screen	Displays all information needed to operate the TC25.
8	Charging/Notification LED	Indicates battery charging status while charging and application generated notifications.
9	Data Capture LED	Indicates data capture status.
10	Microphone	Use for communications in Speakerphone mode.
11	Receiver	Use for audio playback in Handset mode.

Table 2 Front View Features (Continued)

Number	Item	Function
12	Light Sensor	Determines ambient light for controlling display backlight intensity.
13	Proximity Sensor	Determines proximity for turning off display when in handset mode.

Figure 2 TC25 Rear View

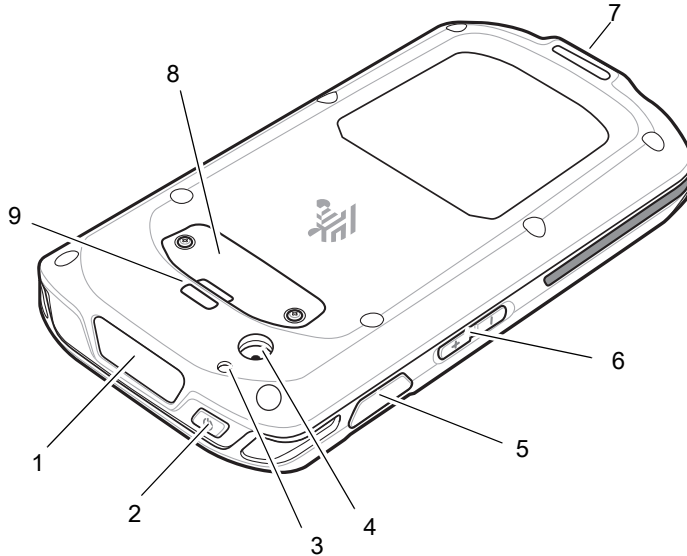

Table 3 Back View Features

Number	Item	Function
1	Imager Window	Provides data capture using the imager.
2	Power Button	Turns the display on and off. Press and hold to reset the device or power off the device.
3	Camera Flash	Provides illumination for the camera.
4	Camera	Takes photos and videos.
5	Scan Button	Initiates data capture.
6	Volume Up/Down Button	Increase and decrease audio volume.
7	Hand Strap Mount Point	Provides latching point for the hand strap.
8	Access Door	Provides access to microSD card slot and SIM card slot. Optional 2-Pin Access Door is available on device with the SE4710 imager for use with the Trigger Handle.
9	Hand Strap Mount Point	Provides latching point for the hand strap.

Setup

Perform this procedure to start using the TC2X for the first time.

1. Install a micro secure digital (SD) card (optional).
2. Installing a nano SIM card
3. Charge the TC25.
4. Power on the TC25.

Installing a microSD Card

The microSD card slot provides secondary non-volatile storage. The slot is located under the access door. Refer to the documentation provided with the card for more information, and follow the manufacturer's recommendations for use.



CAUTION: Use proper electrostatic discharge (ESD) precautions to avoid damaging the microSD card. Proper ESD precautions include, but are not limited to, working on an ESD mat and ensuring that the operator is properly grounded.

1. Using a 0# Phillips screwdriver, remove two screws securing the access door.

Figure 3 Remove Access Door

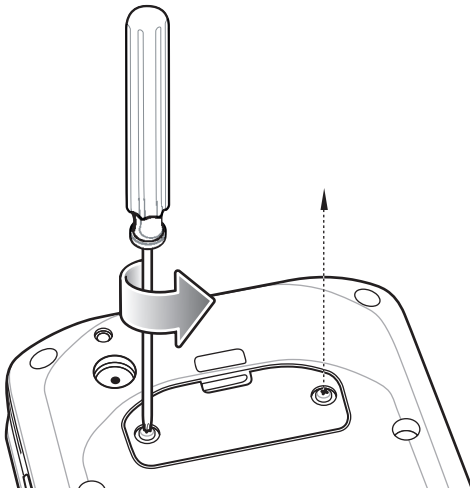

2. Remove access door.

Figure 4 Remove Access Door

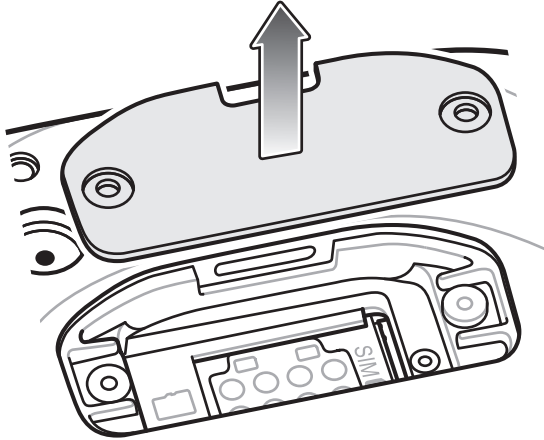

3. Align the microSD card with the SD card slot.

Figure 5 Align microSD Card

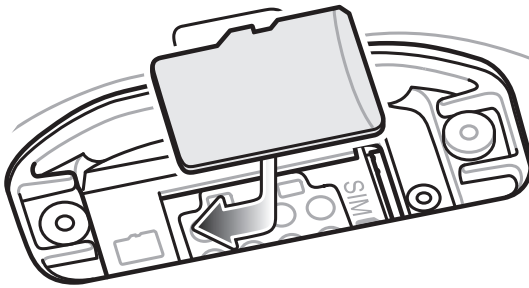

4. Push the microSD card into the SD card slot.

Figure 6 Push microSD Card into the SD Card Slot

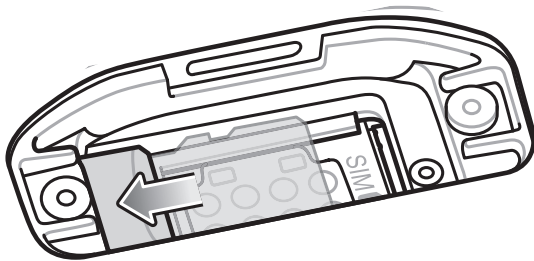

5. Replace the access Door.

6. Secure the access door using the two screws.

Figure 7 Secure Access Door

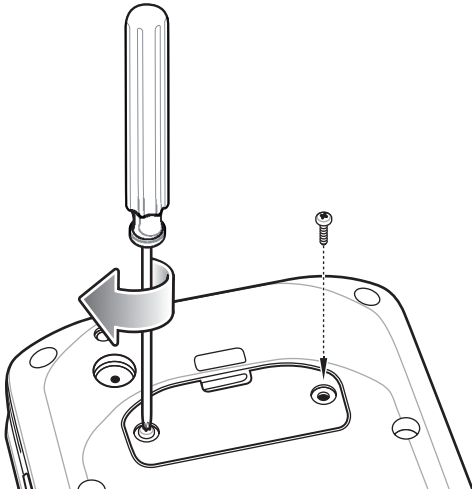

Installing the SIM Card



NOTE: Only use a nano SIM card.

Only use nano SIM cards that meet the ETSI TS102.221 standard for nano SIM cards, form factor 4FF (0.67 mm thick). Do not use SIM cards that are cut from thicker mini or micro SIM cards.



CAUTION: Use proper electrostatic discharge (ESD) precautions to avoid damaging the SIM card. Proper ESD precautions include, but not limited to, working on an ESD mat and ensuring that the user is properly grounded.

1. Using a 0# Phillips screwdriver, remove two screws securing the access door.

Figure 8 Remove Access Door

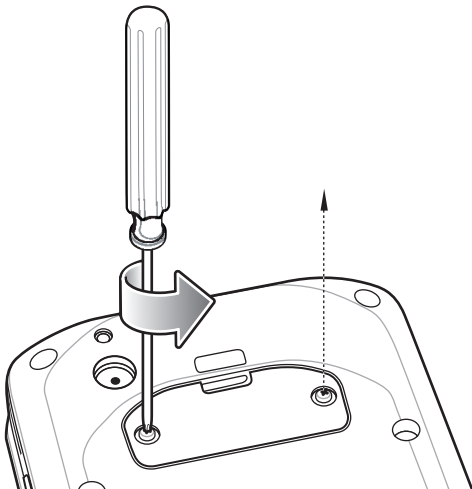

2. Align the SIM card with the SIM card slot with the contacts facing down and the cut edge toward the top of the device.

Figure 9 Align SIM Card with Slot

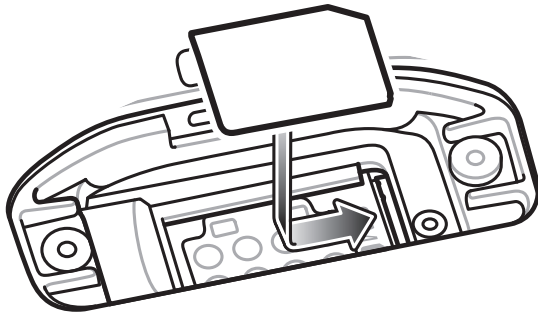

3. Push the SIM card in until it locks into the slot.

Figure 10 Push SIM Card into Slot

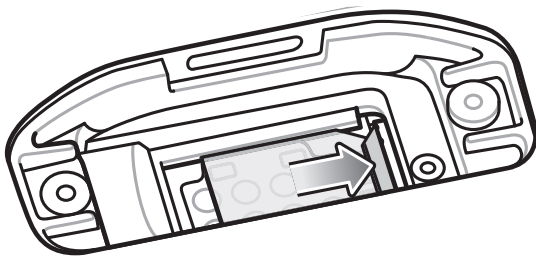

4. Re-install the access door.

Figure 11 Replace Access Door

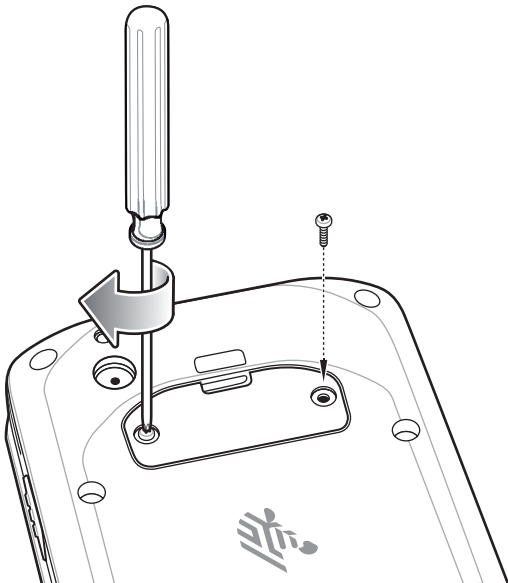

Charging the Battery

Before using the TC25 for the first time, charge the internal battery until the green Charging/Notification light emitting diode (LED) remains lit. To charge the TC25 use a USB-C cable or a cradle with the appropriate

power supply. For information about the accessories available for the TC25 see Accessories for more information.

The internal battery charges from fully depleted to 90% in approximately four hours and from fully depleted to 100% in approximately five hours.



NOTE: In many cases the 90% charge provides plenty of charge for daily use. A full 100% charge lasts for approximately 10 hours of use.

Use only Zebra charging accessories and batteries. Charge batteries at room temperature with the TC25 in sleep mode.

Charge batteries in temperatures from 0°C to 40°C (32°F to 104°F). The TC25 or accessory always performs battery charging in a safe and intelligent manner. At higher temperatures (e.g. approximately +37°C (+98°F)) the TC25 or accessory may for small periods of time alternately enable and disable battery charging to keep the battery at acceptable temperatures. The TC25 or accessory indicates when charging is disabled due to abnormal temperatures via its LED and a notification appears on the display.

To charge the main battery:

1. Connect the charging accessory to the appropriate power source.
2. Insert the TC25 into a cradle or attach to a cable. The TC25 turns on and begins charging. The Charging/Notification LED blinks amber while charging, then turns solid green when fully charged.

Figure 12 Charging with Cradle

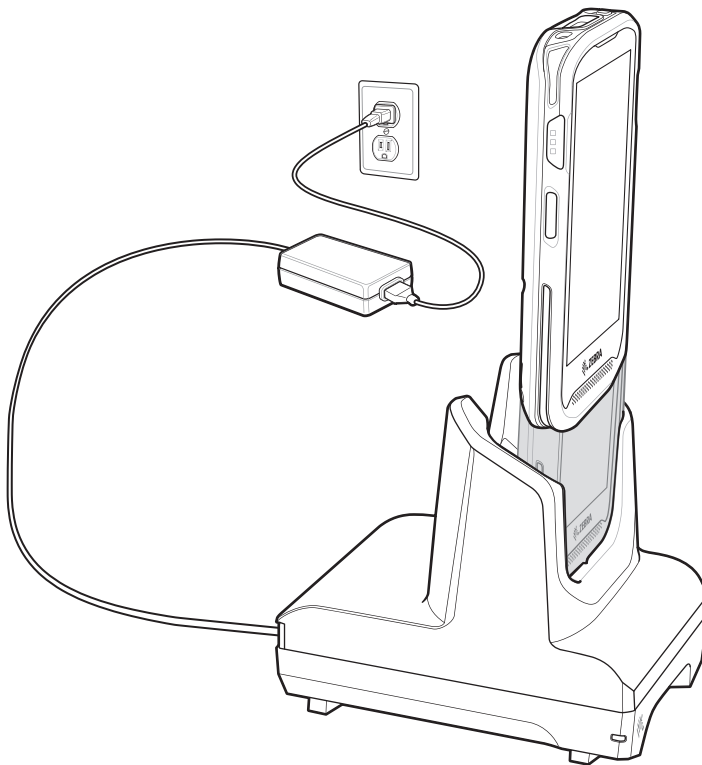

IMPORTANT: Use only the Zebra USB-C Cable for charging.

Figure 13 Charging with USB Cable

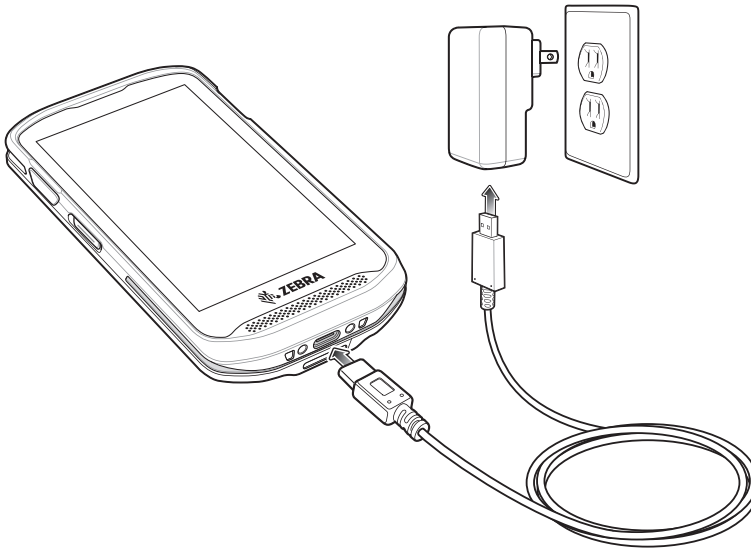



Charging Indicators

Table 4 Charging/Notification LED Charging Indicators

State	LED	Indication
Off		TC25 is not charging. TC25 is not inserted correctly in the cradle or connected to a power source. Charger/cradle is not powered.
Slow Blinking Amber (1 blink every 4 seconds)		TC25 is charging.
Slow Blinking Red (1 blink every 4 seconds)		TC25 is charging but the battery is at end of useful life. See system administrator for battery replacement services.
Solid Green		Charging complete.
Solid Red		Charging complete but the battery is at end of useful life. See system administrator for battery replacement services.

Table 4 Charging/Notification LED Charging Indicators (Continued)

State	LED	Indication
Fast Blinking Amber (2 blinks/second)		Charging error, e.g.: <ul style="list-style-type: none"> • Temperature is too low or too high. • Charging has gone on too long without completion (typically eight hours).
Fast Blinking Red (2 blinks/second)		Charging error but the battery is at end of useful life., e.g.: <ul style="list-style-type: none"> • Temperature is too low or too high. • Charging has gone on too long without completion (typically eight hours). See system administrator for battery replacement services.

Google Account Setup



NOTE: The device has to be connected to the internet in order to set up a Google™ account. A Google account is only required on devices with GMS software.

The first time the device starts, the Setup Wizard displays. Follow the on-screen instructions to set up a Google account, configure Google Pay™ for purchasing items from the Google Play™ store, to enter your personal information, and enable backup/restore features.

Zebra Visibility Services

The device captures and provides device analytics to a system administrator. The first time the device boots (or after a Factory reset), the **Zebra Services** agreement screen displays.

Figure 14 Zebra Services



Touch the **Device Data** switch to disable the device from sending analytics data.

Replacing the microSD Card

To replace the microSD card:

1. Press the Power button until the menu appears.
2. Touch **Power off**.
3. Touch **OK**.
4. If hand strap is attached, remove the hand strap.
5. Using a #0 Phillips screwdriver, remove two screws securing the access door.
6. Remove access door.

Figure 15 Remove Access Door

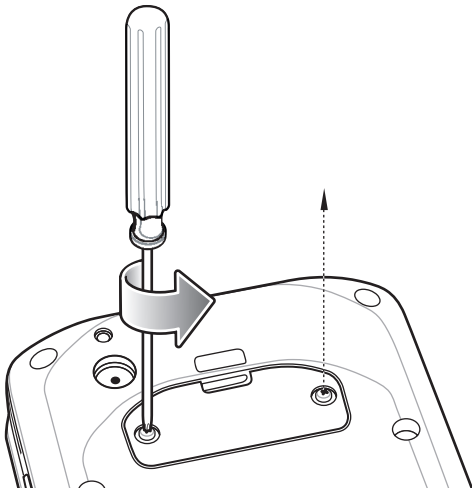

7. Slide the microSD card out of the SD card slot.

Figure 16 Align microSD Card

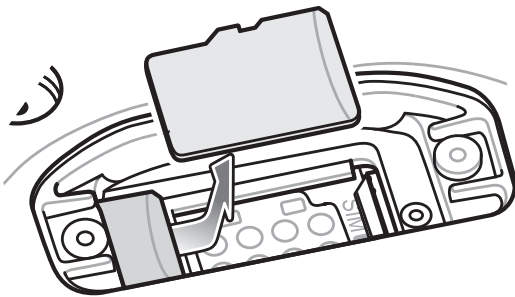

8. Lift the microSD card.
9. Align the replacement microSD card with the SD card slot.

Figure 17 Align microSD Card

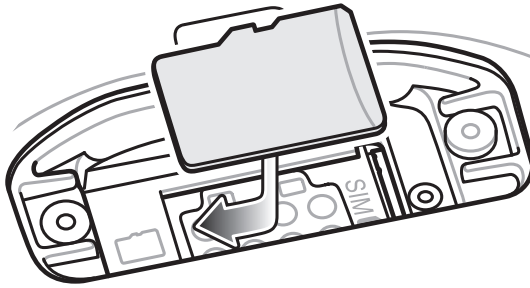

10. Push the microSD card into the SD card slot.

Figure 18 Push microSD Card into the SD Card Slot

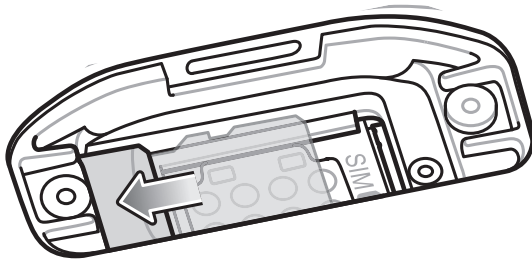

11. Replace the access Door.

12. Secure the access door using the two screws.

Figure 19 Secure Access Door

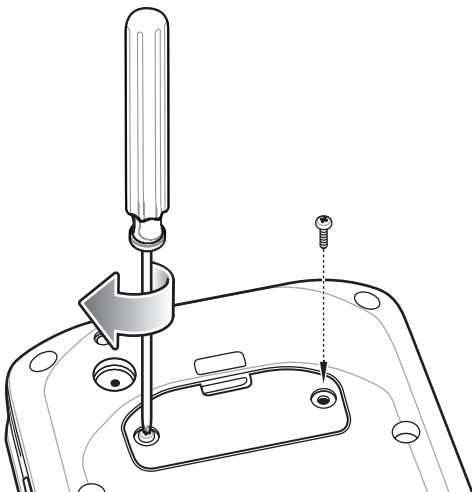

13. Replace the hand strap, if required.

14. Press and hold the Power button to turn on the device.

Replacing the SIM Card



NOTE: Only use a nano SIM card.



CAUTION: Access door must be replaced and securely seated to ensure proper device sealing. TC25 must be powered off when replacing the SIM card.

To replace the SIM card:

1. Press the Power button until the menu appears.
2. Touch **Power off**.
3. Touch **OK**.
4. If hand strap is attached, slide the hand strap clip up toward the top of the TC25 and then lift.
5. Using a 0# Phillips screwdriver, remove two screws securing the access door.

Figure 20 Remove Access Door

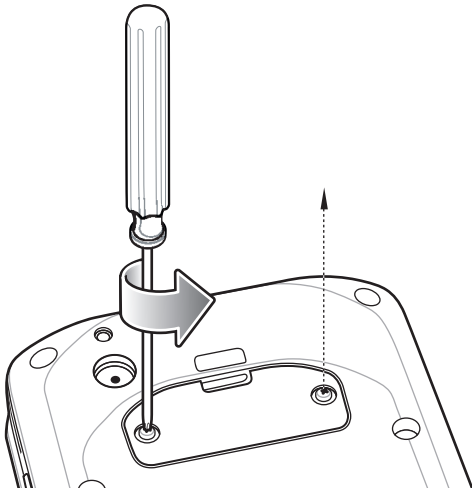

6. Push the SIM card in to eject the card.
7. Remove the SIM card from the slot.
8. Align the replacement SIM card with the SIM card slot with the contacts facing down and the cut edge toward the top of the device.

Figure 21 Align SIM Card with Slot

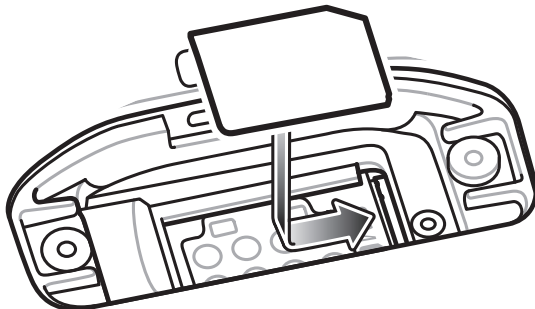

9. Push the SIM card in until it locks into the slot.

Figure 22 Push SIM Card into Slot

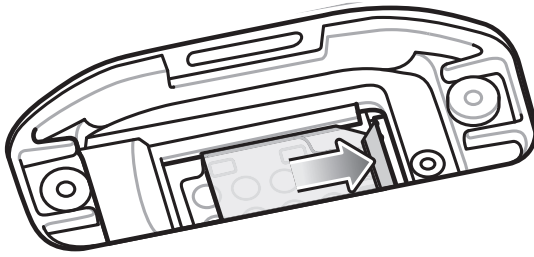

10. Re-install the access door.

Figure 23 Replace Access Door

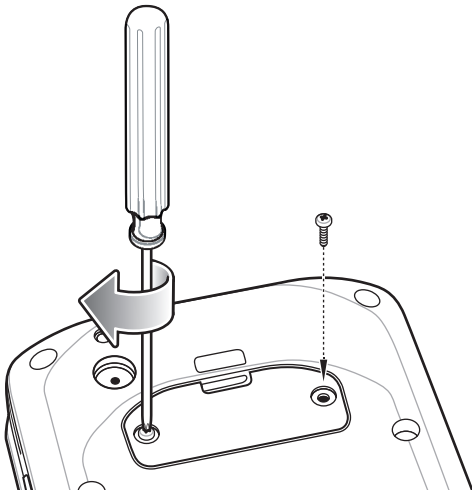



11. Replace the hand strap, if required.

12. Press and hold the Power button to turn on the TC25.

Accessing Device Settings

To access device settings:

1. Swipe down from the Status bar to open the Quick Settings bar and then touch .
2. On the Home screen, swipe up from the bottom of the screen and touch .

Battery Management



NOTE: Prior to checking the battery charge level, remove the device from any AC power source (cradle or cable).

To check the charge status of the main battery, open **Settings** and touch **System > About phone > Battery Information**.

Battery present status indicates if the battery is present and **Battery level** lists the battery charge (as a percentage of fully charged). The battery percentage can also be viewed next to the battery icon in the quick access panel. Swipe down with two fingers from the status bar to open the quick access panel.

Monitoring Battery Usage

The **Battery** screen provides battery charge details, power management options, and a list of apps that consume the most battery power.

Use the power management options to extend battery life, or touch an app to display details about its power consumption. Different apps display different information. Some apps include buttons that open screens with settings to adjust power use. Use the **DISABLE** or **FORCE CLOSE** buttons to turn off apps that consume too much power.

1. Swipe down from the Status bar to open the Quick Settings bar and then touch .
2. Touch **Battery**.

Figure 24 Battery Screen



Low Battery Notification

When the battery charge level drops below 20%, the device displays a notice to connect the device to power. The user should charge the battery using one of the charging accessories.

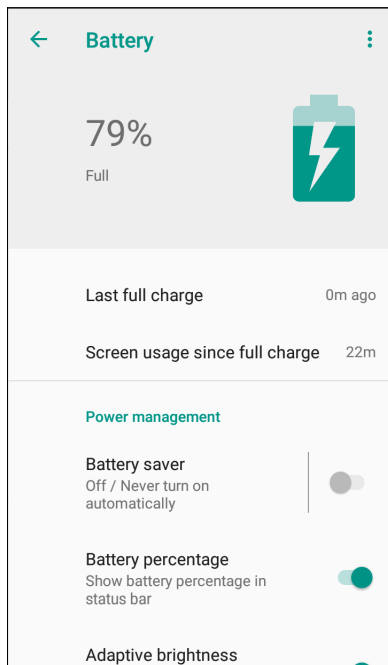
When the battery charge drops below 10%, the device displays a notice to connect the device to power. The user must charge the battery using one of the charging accessories.

When the battery charge drops below 4%, the device turns off. The user must charge the battery using one of the charging accessories.

Figure 25 Low Battery Notification

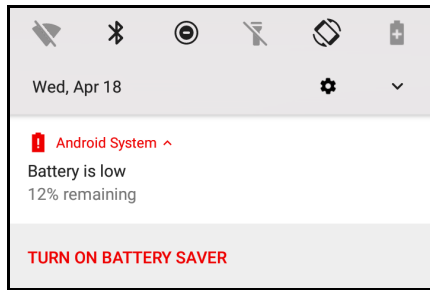

Battery Optimization

Observe the following battery saving tips:

- Set the screen to turn off after a short period of non-use.
- Reduce screen brightness.
- Turn off all wireless radios when not in use.
- Turn off automatic syncing for Email, Calendar, Contacts, and other apps.
- Minimize use of apps that keep the device from suspending, for example, music and video apps.

Turning Off the Radios

To turn off all the radios:

1. Press the Power button until the menu appears.
2. Touch **Airplane mode**. The airplane icon ✈ appears in the Status bar indicating that all the radios are off.

Setting the Date and Time

You are only required to set the time zone or set the date and time if the wireless LAN does not support Network Time Protocol (NTP).

To set the date and time:

1. Swipe down from the Status bar to open the Quick Settings bar and then touch ⚙.
2. Touch **System > Date & time**.
3. Touch **Automatic date & time** to disable automatic date and time synchronization.
4. Touch **Set date**.
5. In the calendar, set today's date.
6. Touch **OK**.
7. Touch **Set time**.
8. Touch the green circle, drag to the current hour and then release.
9. Touch the green circle, drag to the current minute and then release.

10. Touch **AM** or **PM**.
11. Touch **OK**.
12. Touch **Use 24-hour format**.
13. Touch .

Display Settings

Use Display settings to change the screen brightness, enable night light, change the background image, enable screen rotation, set sleep time, and change font size.

Setting the Screen Brightness

To manually set the screen brightness using the touchscreen:

1. Swipe down with two fingers from the Status bar to open the Quick Access panel.
2. Slide the icon to adjust the screen brightness level.

Figure 26 Brightness Slider





To let the device automatically adjust the screen brightness using the built-in light sensor:

1. Swipe down from the status bar to open the quick settings bar and then touch .
2. Touch **Display**.
3. If disabled, touch **Adaptive brightness** to automatically adjust the brightness.
By default, **Adaptive brightness** is enabled. Toggle the switch to disable.
4. Touch .

Setting Screen Rotation

By default, screen rotation is disabled. To enable screen rotation:

1. Swipe down from the status bar and then touch .
2. Touch  **Display**.
3. Touch **When device is rotated** and select **Rotate to contents of the screen** to set the TC25 to automatically switch orientation when the TC25 is rotated.
4. Touch .

Setting Screen Timeout

To set the screen sleep time:

1. Swipe down from the Status bar to open the Quick Settings bar and then touch .

2. Touch **Display > Advanced > Sleep**.
3. Select one of the sleep values.
 - **15 seconds**
 - **30 seconds**
 - **1 minute** (default)
 - **2 minutes**
 - **5 minutes**
 - **10 minutes**
 - **30 minutes** (default).
4. Touch .

Setting Font Size

To set the size of the font in system apps:

1. Swipe down from the Status bar to open the Quick Settings panel and then touch .
2. Touch **Display > Advanced**.
3. Touch **Font size**.

Figure 27 Font Settings



4. Select one of the font size values.
 - Small
 - Default
 - Large
 - Largest.

5. Touch ○.

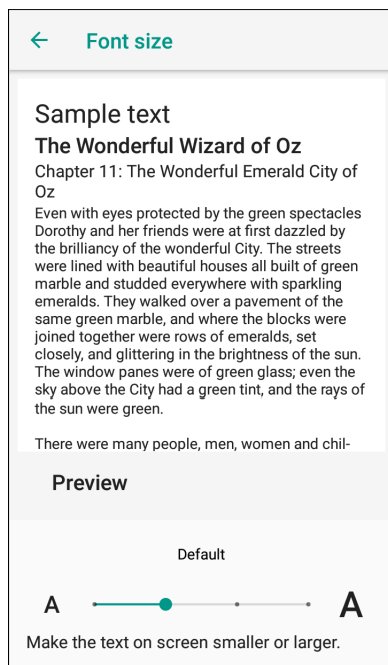
Setting Screen Rotation

By default, screen rotation is enabled.

To disable screen rotation:

1. Swipe down from the Status bar to open the Quick Settings bar and then touch ⚙️.
2. Touch **Display > Advanced**.
3. Touch **Auto-rotate screen**.



NOTE: To change the Home screen rotation, see Setting Home Screen Rotation.

4. Touch ○.

Setting Display Size

By default, display size is set to default.

To change the display size:

1. Swipe down from the Status bar to open the Quick Settings bar and then touch ⚙️.
2. Touch **Display > Advanced**.
3. Touch **Display size**.
4. Touch - and + to change the display size.
 - Small
 - Default
5. Touch ○.

Setting the Charge LED

The user can place the Charging/Notification LED in Standard Mode (default) or Quiet Mode. In Standard Mode, the Charging/Notification LED is on when the device is charging, and the display is on or off. In Quiet Mode, Charging/Notification LED is off when the screen is on and the device is charging, and on when the screen is off and the device is charging.

To enable Quiet Mode:

1. Swipe down from the status bar to open the quick access panel and then touch ⚙️.
2. Touch **Display**.
3. Touch **Charging LED**. The option switch turns green.
4. Touch ○.

General Sound Setting

Use the **Sound** settings to configure media and alarm volumes.

To access sound settings:

1. Swipe down from the Status bar to open the Quick Settings bar and then touch .
2. Touch **Sound**.
3. Touch an option to set sounds.

Figure 28 Sound Screen



- **Media volume** - Controls the music, games, and media volume.
- **Alarm volume** - Controls the alarm clock volume.
- **Ring volume** - Controls the ringtone volume.
- Also vibrate for calls - Switch on or off.
- **Do Not Disturb preferences** - Mutes some or all sounds and vibrations.
 - **Priority only allows** - Use to set the priorities for the following:
 - **Reminders** - Switch on or off.
 - **Events** - Switch on or off.
 - **Alarms** - This is always enabled.
 - **Messages** - Choose to allow messages from anyone, starred contacts, any contact, or none. To star contacts, use the Contacts app.
 - **Calls** - Choose to allow calls from anyone, starred contacts, any contact, or none. To star contacts, use the Contacts app.
 - **Repeat callers** - Choose whether or not the phone rings if the same person calls again within 15 minutes.
 - **Block visual disturbances**
 - **Block when screen is on** - This option prevents notifications from displaying over the screen (peeking) while you are actively using the device.
 - **Block when screen is off** - This option prevents notifications from turning on the screen or pulsing the LED light when a new notification is received while you are not using the device.
 - **Automatic rules** - Choose when to automatically silence the device. Touch a default rule, such as Weekend or Weeknight, or create your own rule. To create your own rule, tap **Add more** and then **Time rule**.

- **Phone ringtone** - Touch to select a sound to play when the phone rings.
- **Advanced** - Touch to display advanced sound options.
 - **Default notification sound** - Touch to select a sound to play for all system notifications.
 - **Default alarm sound** - Touch to select a sound to play for alarms.
 - **Other sounds and vibrations**
 - **Dial pad tones** - Play a sound when pressing keys on dial pad (default - disabled).
 - **Screen locking sounds** - Play a sound when locking and unlocking the screen (default – enabled).
 - **Charging sounds** - Not applicable.
 - **Touch sounds** - Play a sound when making screen selections (default – enabled).
 - **Vibrate on tap** - Vibrate the device when making screen selections (default – disabled).
 - **Emergency alerts** - Touch to configure emergency broadcast settings and notifications.

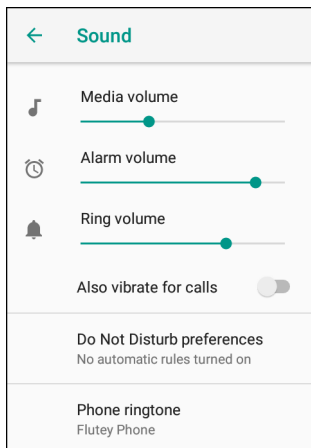
Wake-Up Sources

By default the device wakes from suspend mode when the user presses the power button. The device can be configured to wake when the user presses the PTT on the left side of the device or one of the Scan buttons.



1. Swipe down with two fingers from the status bar to open the quick access panel and then touch .
2. Touch **System > Wake-Up Sources**.
3. Touch one or more of the options:
 - Touch **Key_PTT** checkbox to enable the right scan button. A check appears in the checkbox.
 - Touch **Key_Scan** checkbox to enable the either scan button. A check appears in the checkbox.

Figure 29 Wake-Up Sources

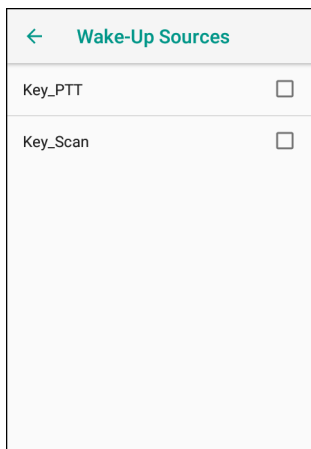

4. Touch .

Using the Device

This chapter explains the buttons, status icons, and controls on the device, and provides basic instructions for using the device including resetting the device and entering data.

Google Mobile Services



NOTE: This section applies to Google Mobile Services (GMS) devices only.

Devices with GMS contain apps and services that provide additional functionality.

GMS includes:

- Apps - GMS adds a variety of Google apps and associated widgets including Chrome, Gmail, Drive, and Maps.
- Services:
 - Speech to Text - Allows for free format speech to text in many languages for both connected and disconnected network. Launch by touching the microphone icon on the keyboard.
 - TalkBack Service - Provides spoken feedback on various parts of the user interface. To enable, go to **Settings > Accessibility**.
 - Network Location Provider - Adds a location provider which uses mobile network tower information and Wi-Fi access point information to provide a location without using GPS. To enable, go to **Settings > Location access**.
 - Widevine DRM - Enables Digital Rights Management (DRM) so that protected streaming video content can be played. Enable DRM Info from the Google Play™ store.
 - Google Cloud Messaging - Allows the device to receive data from the server and other devices on the same connection.
 - Backup and Restore - Allows the users settings and apps to be backed up to a Google server and subsequently restored from that server after a factory reset.
- Google Accounts - Create and use a Google account to synchronize mail, files, music, photos, contacts and calendar events.

Home Screen

Turn on the device to display the Home screen. Depending on the configuration, the Home screen may appear different. Contact your system administrator for more information.

After a suspend or screen time-out, the Home screen displays with the lock slider. Touch the screen and slide up to unlock. For screen locking information, see Un-Locking the Screen.

The Home screen provides additional screens for placement of widgets and shortcuts. Swipe the screen left or right to view the additional screens.



NOTE:

By default, non-GMS devices do not have icons on the Home screen. Icons are shown below for example only.

Home screen icons can be configured by the user and may look different than shown.

Home Screen



Table 5 Home Screen Items

Item	Description
1 — Status Bar	Displays the time, status icons (right side), and notification icons (left side). For more information see Status Bar on page 37 and Managing Notifications on page 40 .
2 — Widgets	Launches stand-alone applications that run on the Home screen. See App Shortcuts and Widgets on page 43 for more information.
3 — Back	Displays the previous screen.
4 — Home	Displays the Home screen.
5 — Recent Button	Displays recently used applications.
6 — All Apps	Opens the APPS window.
7 — Folder	Contains apps.
8 — Shortcut Icons	Opens applications installed on the device. See App Shortcuts and Widgets on page 43 for more information.

The Home screen provides four additional screens for placement of widgets and shortcuts. Swipe the screen left or right to view the additional screens.

Setting Home Screen Rotation

By default the **Home** screen rotation is disabled.

To enable **Home** screen rotation:

1. Touch and hold anywhere on the **Home** screen until the options appear.
2. Touch **HOME SETTINGS**.
3. Touch the **Allow Home screen rotation** switch.
4. Touch .
5. Rotate the device.

Figure 30 Rotated Home Screen

Status Bar

The Status bar displays the time, notification icons (left side), and status icons (right side).



NOTE: Some Status icons may not appear in the Status bar if there are too many icons to display.

Figure 31 Notification and Status Icons



If there are more notifications than can fit in the Status bar, two dots display indicating that more notifications exist. Swipe down from the Status bar to open the Notification panel and view all notifications and status.



















Status Icons

Table 6 Status Icons

Icon	Description
	Alarm is active.
	Main battery is fully charged.
	Main battery is partially drained.
	Main battery charge is low.
	Main battery charge is very low.

¹Cellular network icon that appears is dependent upon the carrier/network.























Table 6 *Status Icons (Continued)*

Icon	Description
	Main battery is charging.
	All sounds, except media and alarms, are silenced and vibrate mode is active.
	Do Not Disturb mode active.
	Airplane Mode is active. All radios are turned off.
	Bluetooth is on.
	The device is connected to a Bluetooth device.
	Connected to a Wi-Fi network.
	Not connected to a Wi-Fi network or no Wi-Fi signal.
	Connected to an Ethernet network.
	Speakerphone enabled.
	Portable Wi-Fi hotspot is active.
	Connected to a 4G LTE/LTE-CA network ¹ .
	Connected to a DC-HSPA, HSDPA, HSPA+, HSUPA, LTE/LTE-CA or WCDMA network ¹ .
	Connected to a 1x-RTT (Sprint), EGDGE, EVDO, EVDV or WCDMA network ¹ .
	Connected to a GPRS network ¹ .
	
	Connected to a 1x-RTT (Verizon) network ¹ .
	Roaming from a network.
	No SIM card installed.

¹Cellular network icon that appears is dependent upon the carrier/network.

Notification Icons

Table 7 Notification Icons

Icon	Description
	Main battery is low.
	More notifications are available for viewing.
	Data is syncing.
	Indicates an upcoming event. Non-GMS devices only.
	Indicates an upcoming event. GMS devices only.
	Open Wi-Fi network is available.
	Song is playing.
	Problem with sign-in or sync has occurred.
	Device is uploading data.
	Device is downloading data when animated and download is complete when static.
	Device is connected to or disconnected from virtual private network (VPN).
	Preparing internal storage by checking it for errors.
	USB debugging is enabled on the device.
	Call is in progress.
	One or more voice message is in mailbox.
	Call is on hold.
	Call was missed.
	Headset is connected to the device.
	PTT Express Voice client status. See the PTT Express PTT Notification Icons for a complete list.
	Indicates that RxLogger app is running.
	Indicates the RS6000 is connected to the device.
	Indicates the RS507 or RS6000 is connected to the device in HID mode.

Managing Notifications

Notification icons report the arrival of new messages, calendar events, alarms, and ongoing events. When a notification occurs, an icon appears in the Status bar with a brief description. See Notification Icons for a list of possible notification icons and their description. Open the Notification panel to view a list of all the notifications.

To open the Notification panel, drag the Status bar down from the top of the screen.

Figure 32 Notification Panel

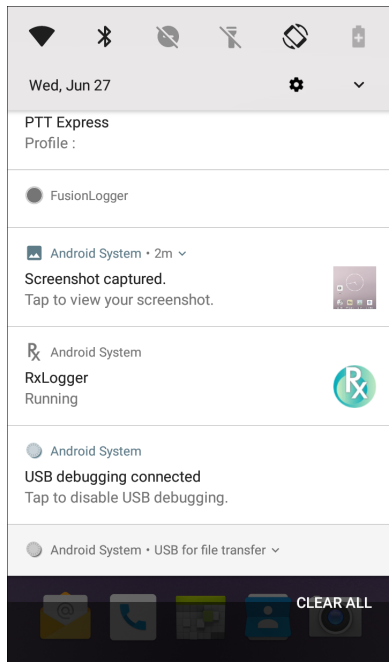

To respond to a notification, open the Notification panel and then touch a notification. The Notification panel closes and the corresponding app opens.

To clear all notifications, open the Notification panel and then touch **CLEAR ALL**. All event-based notifications are removed. Ongoing notifications remain in the list.

To close the Notification panel, swipe the Notification panel up.

Setting App Notifications

To set notification settings for a specific app:

1. Swipe down from the Status bar to open the Quick Settings bar and then touch **⚙️**.
2. Touch **Apps & notifications > Notifications > App notifications**.
3. Select an app.

4. Select an available option:
 - **On / Off** - Select to turn all notifications from this app **On** (default) or **Off**.
 - **Allow notification dot** - Do not allow this app to add a notification dot to the app icon.
 - **Allow interruptions** - Do not allow notifications from this app to make sound, vibrate, or pop notifications on the screen.
 - **Override Do Not Disturb** - Allow these notifications to interrupt when Do Not Disturb is set to Priority Only.
 - **Categories** - Do not allow specific types of notifications from this app.
 - **Additional settings in the app** - Open the app settings.



NOTE: To change the notification settings for an app, slide the notification slightly left or right and touch .

Viewing Notification Settings for All Apps

To view the notification settings for all apps:

1. Swipe down from the Status bar to open the Quick Settings bar and then touch .
2. Touch **Apps & Notifications**.
3. Scroll down to **Notifications** to view how many apps have notifications turned off.
4. To set or view notifications settings for a specific app, see Setting App Notifications.

Controlling Lock Screen Notifications

To control whether notifications can be seen when the device is locked:

1. Swipe down from the Status bar to open the Quick Settings bar and then touch .
2. Touch **Apps & notifications > Notifications**.
3. Touch **On the lock screen** and select one of the following:
 - **Show all notification content** (default)
 - **Don't show notifications at all**.

Quick Access Panel

Use the Quick Access panel to access frequently used settings (for example, Airplane mode).

Figure 33 Quick Settings Bar

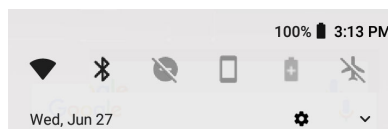

To see the full Quick Access panel:

- If the device is locked, swipe down once.
- If the device is unlocked, swipe down once with two fingers, or twice with one finger.
- If the Quick Settings bar is open, touch the Down arrow.

Figure 34 Quick Access Panel

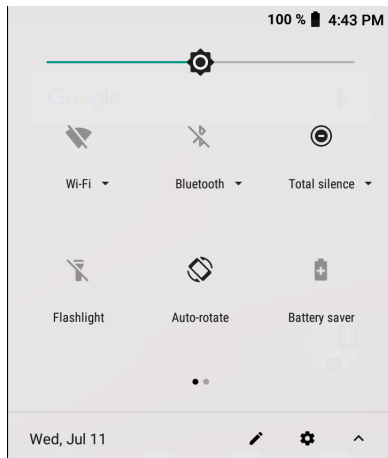

NOTE: Not all icons are pictured. Icons may vary.



To change a setting, touch the icon:

- Display brightness - Use the slider to decrease or increase the brightness of the screen.
- Wi-Fi network - Turn Wi-Fi on or off. To open Wi-Fi settings, touch the Wi-Fi network name.
- Bluetooth settings - Turn Bluetooth on or off. To open Bluetooth settings, touch **Bluetooth**.
- Battery saver - Turn Battery saver mode on or off. When Battery saver mode is on the performance of the device is reduced to preserve battery power.
- Invert colors - Invert the display colors.
- Do not disturb - Control how and when to receive notifications.
- Mobile data - Turns cellular radio on or off. To open Mobile data settings, touch and hold(WAN only).
- Airplane mode - Turn Airplane mode on or off. When Airplane mode is on the device does not connect to Wi-Fi or Bluetooth.
- Auto-rotate - Lock the device's orientation in portrait or landscape mode or set to automatically rotate.
- Flashlight - Turn flashlight on or off. Turn camera flash on or off.
- Night Light - Tint the screen amber to make it easier to look at the screen in dim light. Set Night Light to turn on automatically from sunset to sunrise, or at other times.



Editing Icons on Quick Settings

The first several setting tiles from the Quick Access panel become the Quick Settings bar.



To move a setting tile:

1. Open the Quick Access panel.
2. Touch .
3. Touch and drag a setting tile to another location.
4. Release the tile.
5. Touch  to save tiles and return to the Quick Access panel.

To add a setting tile:

1. Open the Quick Access panel.
2. Touch .
3. Slide the Quick Settings panel up to reveal additional tiles.
4. Touch and drag a setting tile from the **Drag to add tiles** area to the main area.
5. Release the tile.
6. Touch  to save tiles and return to Quick Access panel.

To remove a setting tile:

1. Open the Quick Access panel.
2. Touch .
3. Touch and drag a setting tile to the **Drag here to remove** area.
4. Release the tile.
5. Touch  to save tiles and return to Quick Access panel.

App Shortcuts and Widgets

App shortcuts placed on the Home screen allow quick and easy access to apps. Widgets are self-contained apps placed on the Home screen to access frequently used features.

Adding an App Shortcut to the Home Screen

To add an app shortcut to the Home screen:

1. Go to the desired Home screen.
2. Swipe up from the bottom of the screen.
3. Scroll through the list to find the app icon.
4. Touch and hold the icon until the Home screen appears.
5. Position the icon on the screen and then release.

Adding a Widget to the Home Screen

To add a widget to the Home screen:

1. Go to the desired Home screen.
2. Touch and hold until the menu appears.
3. Touch **WIDGETS**.
4. Scroll through the list to find the widget.
5. Touch and hold the widget until the Home screen appears.
6. Position the widget on the screen and then release.

Moving Items on the Home Screen

To move app shortcuts or widgets on the Home screen:

1. Touch and hold the item until it floats on the screen.
2. Drag the item to a new location. Pause at the edge of the screen to drag the item onto an adjacent Home screen.
3. Lift finger to place the item on the Home screen.

Removing an App Shortcut or Widget from the Home Screen

To remove an app shortcut or widget from the Home screen:

1. Go to the desired Home screen.
2. Touch and hold the app shortcut or widget icon until it floats on the screen.
3. Drag the icon to **X Remove** at the top of the screen and then release.

Folders

Use **Folders** to organize similar applications together. Tap the folder to open and display items in the folder.

Creating a Folder

There must be at least two app icons on the Home screen.

To create a folder:

1. Go to the desired Home screen.
2. Touch and hold one app icon.
3. Drag the icon and stack on top of another icon.
4. Lift and release.

Naming Folders

To name a folder:

1. Touch the folder.

Figure 35 Open Folder

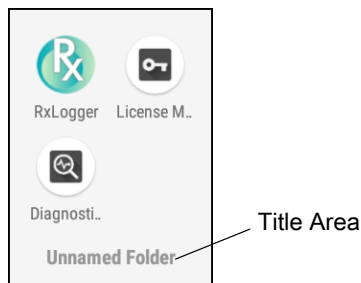

2. Touch the title area and enter a folder name using the keyboard.

3. Touch  on the keyboard.
4. Touch anywhere on the Home screen to close the folder. The folder name appears under the folder.

Removing a Folder

To remove a folder:

1. Touch and hold the folder icon until it enlarges.
2. Drag the folder to **X Remove** and release.

Home Screen Wallpaper

To change the Home screen wallpaper:

1. Touch and hold the screen until the menu appears.
2. Touch **WALLPAPERS**.
3. Touch **Photos** or **Gallery** to select a photo or select one of the pre-installed wallpapers.
4. Touch **Set wallpaper**.

Using the Touchscreen

Use the multi-tap sensitive screen to operate the device.

- Tap - Tap to:
 - Select items on the screen.
 - Type letters and symbols using the on-screen keyboard.
 - Press on-screen buttons.
- Tap and Hold - Tap and hold:
 - An item on the Home screen to move it to a new location or to the trash.
 - An item in Apps to create a shortcut on the Home screen.
 - The Home screen to open a menu for customizing the Home screen.
 - An empty area on the Home screen until the menu appears.
- Drag - Tap and hold an item for a moment and then move finger on the screen until reaching the new position.
- Swipe - Move finger up and down or left and right on the screen to:
 - Unlock the screen.
 - View additional Home screens.
 - View additional app icons in the Launcher window.
 - View more information on an app's screen.
- Double-tap - Tap twice on a web page, map, or other screen to zoom in and out.
- Pinch - In some apps, zoom in and out by placing two fingers on the screen and pinching them together (to zoom out) or spreading them apart (to zoom in).

On-Screen Keyboards



Use the on-screen keyboard to enter text in a text field.

Editing Text

Edit entered text and use menu commands to cut, copy, and paste text within or across applications. Some applications do not support editing some or all of the text they display; others may offer their own way to select text.

Entering Numbers, Symbols and Special Characters

To enter numbers and symbols:

- Touch and hold one of the top-row keys until a menu appears then select a number. Keys with alternate characters display an ellipsis (...) below the character.
- Touch and hold the Shift key with one finger, touch one or more capital letters or symbols to enter them, and then lift both fingers to return to the lowercase keyboard.
- Touch  to switch to the numbers and symbols keyboard.
- Touch the  key on the numbers and symbols keyboard to view additional symbols.

To enter special characters, touch and hold a number or symbol key to open a menu of additional symbols.

- A larger version of the key displays briefly over the keyboard.
- Keys with alternate characters display an ellipsis (...) below the character.

Hiding On-Screen Keyboard

On devices with keypads, the user can hide the on-screen keyboard.



Touch in a text field to display the on-screen keyboard. Touch  at the bottom right corner of the screen.

Figure 36 Hide Keyboard Option

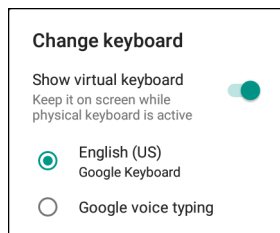

Touch the **Show virtual keyboard** switch to off. The on-screen keyboard automatically disappears.

To show the on-screen keyboard, Touch in a text field. Touch  at the bottom right corner of the screen. Touch the Show virtual keyboard switch to on. The keyboard re-appears.

Switching Language Keyboards

The user can enable multiple language keyboards. The available language codes appear on the space bar.

Figure 37 Keyboard with Multiple Languages

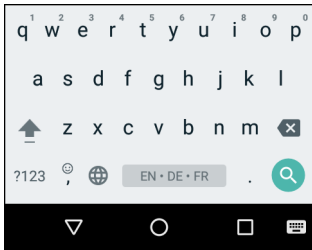

To switch between language keyboard, touch  at the bottom right corner of the screen.

Figure 38 Change Keyboard Option





Select one of the keyboard languages. The keyboard automatically changes to the selected language.

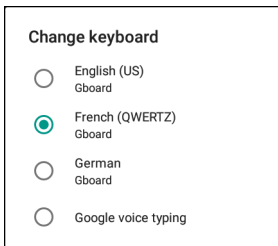

Configuring the Keyboard

To configure the keyboard, See the Keyboard Settings section in the TC20 Touch Computer Integrator Guide for Android 8.1.0 Oreo.

AOSP Keyboard

To configure the keyboard settings, touch and hold  (comma) >  and then select **Android Keyboard Settings (AOSP)**.

GMS Keyboard

To configure the keyboard settings, touch and hold  (comma) >  and then select Gboard Keyboard settings.

Do Not Disturb Feature

This mode mutes the device so that it does not make sounds or vibrate.

For example, use Do Not Disturb to:

- Automatically limit sounds at night or during events
- Mute interruptions other than alarms
- Get alerted to messages only from favorite contacts.

Limit Sounds and Vibrations

Mute the device completely, or let through the important alarms or important calls.

Total Silence

To completely mute the device so that it does not make a sound or vibrate, choose **Total silence**.

In Total silence mode:

- Alarms do not make noise.
- Device does not vibrate or make sounds when receiving a message, or notification.
- Sounds from music, videos, games, and other media are muted.



NOTE: All alarms are silenced in Total silence mode.

1. Swipe down with two fingers from the Status bar to open the Quick Access panel.
2. Touch **Do not disturb > Total silence**.
3. Choose **Until you turn it off** or select a time period.
4. Touch **Done**.

When Total Silence is on,  appears in the quick access panel and the Status bar.

To turn off Total Silence, open quick access panel and touch **Total silence**.

Alarms Only

To mute the device so that you hear alarms, choose **Alarms only**. This option does not mute sounds from music, videos, games, or other media.

1. Swipe down with two fingers from the status bar to open the quick access panel.
2. Touch **Do not disturb > Alarms only**.
3. Choose **Until you turn it off** or select a time period.
4. Touch **Done**.

When Alarms Only is on,  appears in the quick access panel and the Status Bar.

To turn off Alarms Only, open the Quick Access panel and touch **Alarms only**.



NOTE: To quickly turn on Alarms Only, with the screen on, press and hold the Volume Down button until the volume is all the way down. Then, press Volume Down again to turn on Alarms Only.

To turn off Alarms Only, press either the Volume Up or Volume Down button and the touch **END NOW** in the alert message.

Priority Notifications Only

To only be interrupted by important notifications, choose **Priority only**. This option does not mute sounds from music, videos, games, or other media.

Before turning on Priority Only mode, set the notification priorities:

1. Swipe down from the status bar to open the quick settings bar and then touch .
2. Touch **Sound > Do not disturb > Priority only allows**.

3. Set priorities.
 - **Alarms:** Disabled by default.
 - **Reminders** and **Events:** Switch on or off.
 - **Messages** and **Calls:** Choose **From anyone**, **From contacts only**, **From starred contacts only**, or **none**. To star contacts, use the **Contacts** applications.
 - **Repeat callers:** Choose whether to let the device ring if the same person calls again within 15 minutes.

After setting notification priorities, turn on Priority Only mode to limit interruptions. The priority notifications make a sound or vibrate based on the current ringer volume, but other notifications will be silenced.

1. Swipe down with two fingers from the status bar to open the quick access panel.
2. Touch **Do not disturb > Priority only**.
3. Choose **Until you turn it off** or select a time period.
4. Tap **Done**.

When Priority Only is on,  appears in the quick access panel and the Status Bar.

To turn off Priority Only, open quick access panel and touch **Priority only**.

Automatically Block Sounds and Vibrations

Automatically silence the device during certain times or events, turn sounds back on, and override Do Not Disturb mode.

Silence Sounds During Certain Times

To automatically silence the device during certain times, like at night or on weekends:

1. Swipe down from the Status bar to open the Quick Settings bar and then touch .
2. Touch **Sound > Do Not Disturb preferences**.
3. Touch a default **Weekend** or **Weeknight**. Or, to make a new rule, touch **Add more > Time rule**.
4. Enter a rule name.
5. Touch **OK**.
6. Edit the new rule:
 - **Rule name** - Rename the rule.
 - **Days, Start time, and End time** - Set the rule's schedule.
 - **Do Not Disturb preferences** - Choose whether the rule uses **Alarms only**, **Priority only**, or **Total silence**.
 - **Alarm can override end time** - Allow the alarm to continue to make sound until the next alarm begins.
7. Touch the On/Off switch at the top to turn on the rule.



Silence Sounds During Events and Meetings

To automatically silence the device during events or meetings, set an event rules.

1. Swipe down from the Status bar to open the Quick Settings bar and then touch .

2. Touch **Sound > Do Not Disturb preferences**.
3. To edit the default rule, touch **Event**. Or, to create a new rule, touch **Add rule > Event rule**.
4. Edit the rule settings.
 - **Rule name** - Rename the rule.
 - **During events for** - Select which Google Calendar events the rule uses.
 - **Where reply is** - Set to: **Yes, Maybe, or Not replied, Yes or Maybe, or Yes**.
 - **Do Not Disturb preferences** - Choose whether the rule uses **Priority only, Alarms only, or Total silence**.
5. Touch the On/Off switch at the top to turn on the rule.

Turn Sounds Back On

When the device is in Do Not Disturb mode, Alarms only or Priority only display as , or Total silence displays as .

To turn off Do Not Disturb, either:

- In the Quick Access panel, touch **Alarms only, Priority only, or Total silence**.
- Press the Volume Down button and touch **End Now**.

Override Do Not Disturb for Specific Apps

To let through notifications from specific apps:

1. Swipe down from the Status bar to open the Quick Settings bar and then touch .
2. Touch **Apps & notifications > Notifications > App notifications**.
3. Touch an app.
4. Touch **Override Do Not Disturb**.

Apps

The **APPS** screen displays icons for all installed apps. The table below lists the apps installed on the device. Refer to the device Integrator Guide for Android Version 8.1 for information on installing and uninstalling apps.

Table 8 Apps





















Icon	Description
	Bluetooth Pairing Utility – Use to pair the RS507 Hands-free Imager with the device by scanning a barcode.
	Calculator - Provides the basic and scientific arithmetic functions.
	Calendar - Use to manage events and appointments. GMS devices only
	Calendar - Use to manage events and appointments. Non-GMS devices only.
	Camera - Take photos or record videos. For more information see Camera.
	Chrome - Use to access the Internet or intranet. GMS devices only
	Chromium - Use to access the Internet or intranet. Non-GMS devices only.
	Clock - Use to schedule alarms for appointments or as a wake-up.
	Contacts - Use to manage contact information. See Contacts for more information.
	DataWedge - Enables data capture using the imager.
	Diagnostic Tool - Use to diagnose the device.
	Drive - Upload photos, videos, documents, and other files to personal storage site. GMS devices only
	Duo - A one-to-one video calling app.

Table 8 Apps (Continued)

Icon	Description
	DWDemo - Provides a way to demonstrate the data capture features using the imager. See DataWedge Demonstration for more information.
	Email - Use to send and receive email. Non-GMS devices only.
	Files - Organize and manage files on the device. See Files for more information.
	Gallery - Use to view photos stored on the microSD card. For more information, see Gallery for more information. Non-GMS devices only.
	Gmail - Use to send and receive email using a Google email account. GMS devices only
	Google - Launches Google™ search app. GMS devices only
	Hangouts - Use to communicate with friends using text messages and photos. GMS devices only
	Install ATL - Use to download and install the Asset Tracker Lite application from the Zebra Support site. For information on Asset Tracker Lite application, refer to the Asset Tracker Lite User Guide.
	License Manager - Use to manage software licenses on the device.
	Maps - Use to see your location on a map (with public transit, traffic, or satellite overlays). Search for any business or place of interest. Provides turn-by-turn navigation with voice guidance, traffic-avoidance, and alternate routes, for drivers, cyclists, walkers, and users of public transportation. GMS devices only
	Messaging - Send SMS and MMS messages. See Messaging for more information. WAN devices only.
	Phone - Use to dial a phone number when used with some Voice over IP (VoIP) clients (VoIP telephony ready only). WAN devices only.
	Photos - Use to sync photos with Google account. For more information, see Photo Settings. GMS devices only
	Play Movies & TV - View movies and video on your device. GMS devices only

Table 8 Apps (Continued)

Icon	Description
	Play Music - Use to listen to music. GMS devices only
	Play Store - Download music, movies, books, and Android apps and games from the Google Play Store. GMS devices only
	PTT Express - Use to launch PTT Express client for VoIP communication.
	RxLogger - Use to diagnose device and app issues. See the device Integrator Guide for Android Version 8.1 for more information.
	RxLogger Utility - Use to view, backup, and archive RxLogger data.
	Search - Use to search the Web. Requires an Internet connection. Non-GMS devices only.
	Settings - Use to configure the device.
	Sound Recorder - Use to record audio.
	StageNow - Allows the device to stage a device for initial use by initiating the deployment of settings, firmware, and software.
	User Guide Download - Use to download and install User Guide apk.
	Videos - Use to view videos on the device. Non-GMS devices only.
	Voice Search - Use to perform searches by asking questions. GMS devices only
	YouTube - Use to view videos on the YouTube™ web site. GMS devices only

Accessing Apps

All apps installed on the device are accessed using the **APPS** window.

1. On the Home screen, swipe up from the bottom of the screen.

Figure 39 APPS Window Example

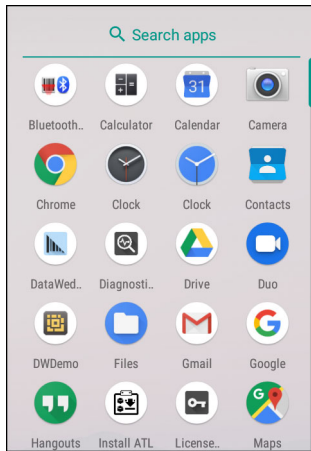

Slide the **APPS** window up or down to view more app icons. Touch an icon to open the app.

Switching Between Recent Apps

To switch between recent apps:

1. Touch . A window appears on the screen with icons of recently used apps.

Figure 40 Recently Used Apps



2. Slide the apps displayed up and down to view all recently used apps.

3. Swipe left or right to remove app from the list and force close the app.
4. Touch an icon to open an app or touch ◀ to return to the current screen.

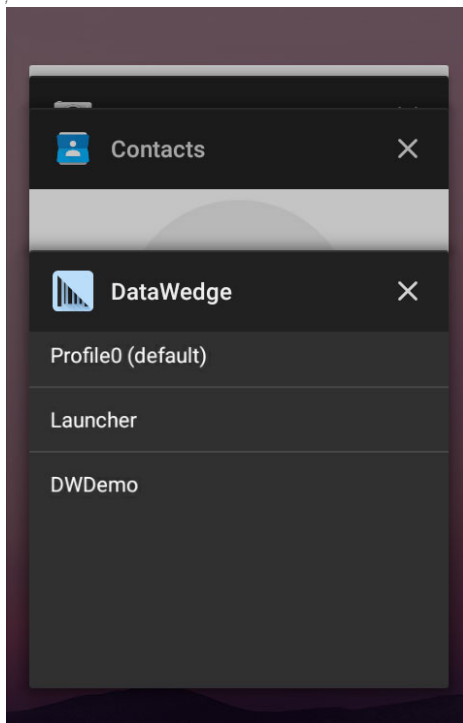
Un-Locking the Screen

Use the Lock screen to protect access to data on the device. Some email accounts require locking the screen. Refer to the device Integrator Guide for information on setting up the locking feature.

When locked, a pattern, PIN, or password is required to unlock the device. Press the Power button to lock the screen. The device also locks after a pre-defined time-out.

Press and release the Power button to wake the device. The Lock screen displays. Swipe the screen up to unlock. If the Pattern screen unlock feature is enabled, the Pattern screen appears instead of the Lock screen. If the PIN or Password screen unlock feature is enabled, enter the PIN or password after unlocking the screen.

Figure 41 Lock Screen

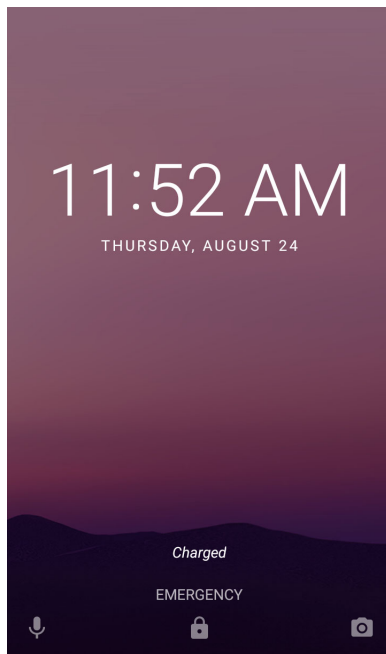

Figure 42 PIN Screen

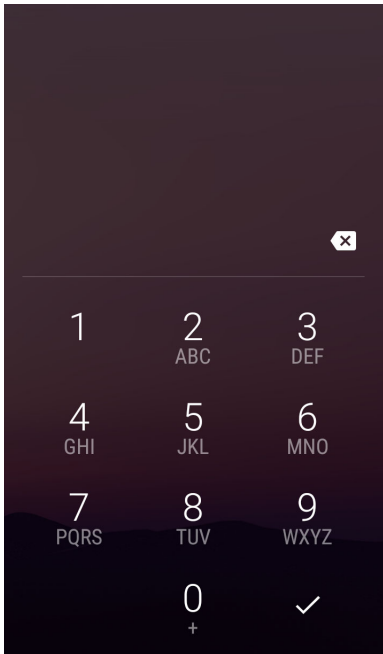

Figure 43 Pattern Screen

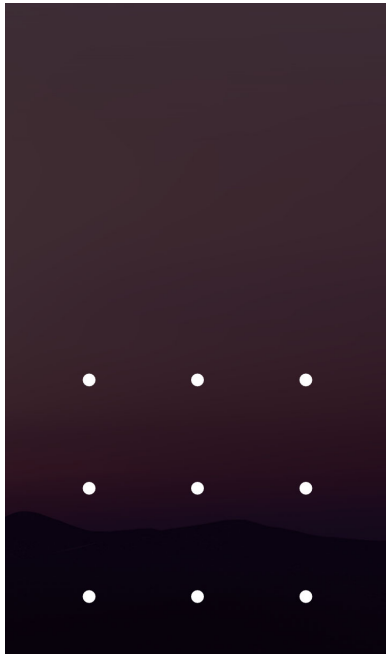
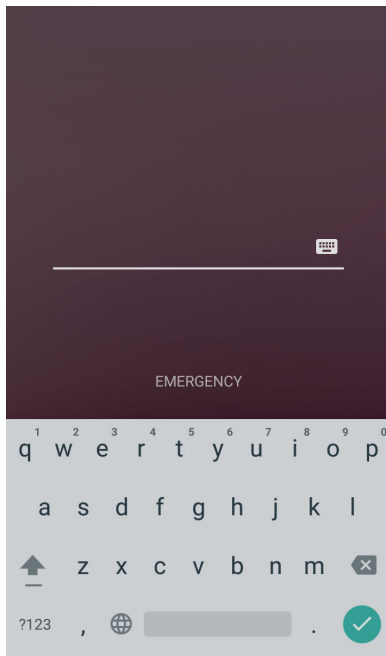

Figure 44 Password Screen



Resetting the Device

There are two reset functions, soft reset and hard reset.

Performing a Soft Reset

Perform a soft reset if applications stop responding.

1. Press and hold the Power button until the menu appears.
2. Touch **Reset**.
3. The device reboots.

Performing a Hard Reset



CAUTION: Performing a hard reset with a microSD card installed in the device may cause damage or data corruption to the microSD card.

Perform a hard reset if the device stops responding.

1. Simultaneously press the Power and Volume Up buttons for at least five seconds.
2. When the screen turns off, release the buttons.
3. The device reboots.

Suspend Mode

The device goes into suspend mode when the user presses the Power button or after a period of inactivity (set in the Display settings window).

To wake the device from Suspend mode, press the Power button. The Lock screen displays. Swipe the screen up to unlock. If the Pattern screen unlock feature is enabled, the Pattern screen appears instead of the Lock screen. If the PIN or Password screen unlock feature is enabled, enter the PIN or password after unlocking the screen.



NOTE: If the user enters the PIN, password or pattern incorrectly five times, they must wait 30 seconds before trying again.

If the user forgets the PIN, password or pattern contact the system administrator.

Transferring Files with a Host Computer via USB

Connect the device to a host computer using a USB cable or a USB cradle to transfer files between the device and the host computer.

When connecting the device to a host computer, follow the host computer's instructions for connecting and disconnecting USB devices, to avoid damaging or corrupting files.

Transferring Files



NOTE: Use Transfer files to copy files between the device (internal memory or microSD card) and the host computer.

1. Connect a USB cable to the device or place the device into a USB cradle.
2. Pull down the Notification panel and touch **USB charging this device**.
By default, **Charge this device** is selected.

Figure 45 Use USB to Dialog Box

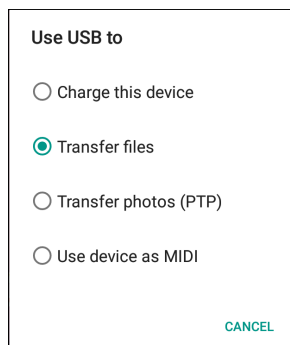

3. Touch **Transfer files**.
4. On the host computer, open a file explorer application.
5. Locate the **device** as a portable device.
6. Open the **SD card** or the **Internal storage** folder.
7. Copy files to and from the device or delete files as required.

Transferring Photos

To transfer photos using Photo Transfer Protocol:



NOTE: Use Photo Transfer Protocol (PTP) to copy photos from either the microSD card or internal memory to the host computer.

1. Connect USB cable to the device or place the device into a USB cradle. See [Accessories](#) for setup information.
2. Pull down the Notification panel and touch **USB charging this device**.
3. Touch **Transfer photos (PTP)**.
4. On the host computer, open a file explorer application.
5. Open the **SD card** or the **Internal storage** folder.
6. Copy or delete photos as required.

Disconnect from the Host Computer

To disconnect the device from the host computer:



CAUTION: Carefully follow the host computer's instructions to unmount the microSD card and disconnect USB devices correctly to avoid losing information.

1. On the host computer, unmount the device.
2. Remove the USB from the device or remove the device from the cradle.

Calls

Introduction

Make a phone call from the **Phone** app, the **Contacts** app, or other apps or widgets that display contact information. This section applies to WWAN devices only.

Emergency Calling

The service provider programs one or more emergency phone numbers, such as 911 or 999, that the user can call under any circumstances, even when the phone is locked, a SIM card is not inserted or the phone is not activated. The service provider can program additional emergency numbers into the SIM card. However, the SIM card must be inserted in the device in order to use the numbers stored on it. See the service provider for additional information.



NOTE: Emergency numbers vary by country. The phone's pre-programmed emergency number(s) may not work in all locations, and sometimes an emergency call cannot be placed due to network, environmental, or interference issues.

Audio Modes

The device offers three audio modes for use during phone calls:

- Handset Mode - Switch audio to the receiver at the top front of the device to use the device as a handset. This is the default mode.
- Speaker Mode - Use the device as a speakerphone.
- Headset Mode - Connect a Bluetooth or wired headset to automatically switch audio to the headset.

Using a Bluetooth Headset

Use a Bluetooth headset for audio communication when using an audio-enabled app. See [Bluetooth on page 126](#) for information on connecting a Bluetooth headset to the device. Set the volume appropriately before putting on the headset. When a Bluetooth headset is connected, the speakerphone is muted.

Adjusting Audio Volume

Use the volume buttons to adjust the phone volume in the following ways:

- Ring and notification volumes when not in a call
- Conversation volume during a call.

Making a Call Using the Dialer

Use the dialer tab to dial phone numbers.



1. On the Home screen touch .
2. Touch .

Figure 46 Dialer Screen







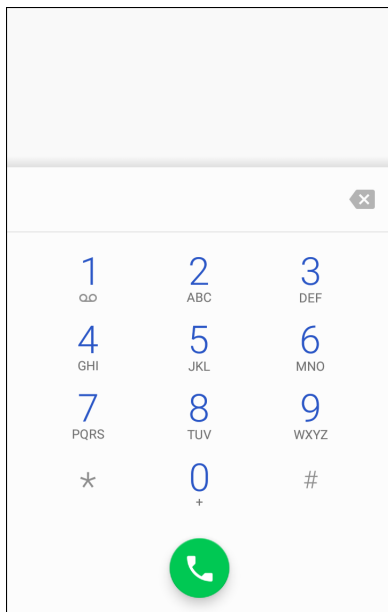



3. Touch the keys to enter the phone number.
4. Touch  below the dialer to initiate the call.

Figure 47 Call in Progress





-  - Send audio to the speakerphone.
 -  - Mute the call.
 -  - Display the dial pad.
 -  - Place the call on hold (not available on all services).
 -  - Create a conference call.
 -  - Increase audio level.
5. Touch  to end the call.

If using a Bluetooth headset, additional audio options are available. Touch the audio icon to open the audio menu.

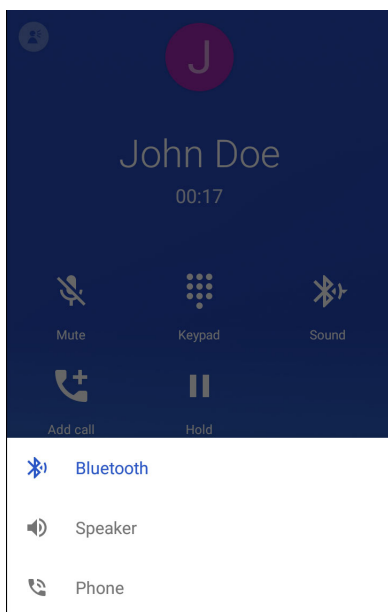
Figure 48 Bluetooth Audio Options



-  - Audio is routed to the Bluetooth headset.
-  - Audio is routed to the speakerphone.
-  - Audio is routed to the earpiece.

Dialer Dialing Options

The dialer provides options to save the dialed number to contacts, send an SMS, or insert pauses and wait into the dial string.

Enter at least one digit to access these options. Touch  to access the following.

- **Add 2-sec pause** - Pause the dialing of the next number for two seconds. Multiple pauses are added sequentially.
- **Add wait** - Wait for confirmation to send the rest of the digits.

Making a Call Using Contacts

There are two ways to make a call using contacts:

- Using the Dialer
- Using the Contacts app.

Using the Dialer





1. On the Home screen touch .
2. Touch the  tab.

Figure 49 Dialer Contacts Tab

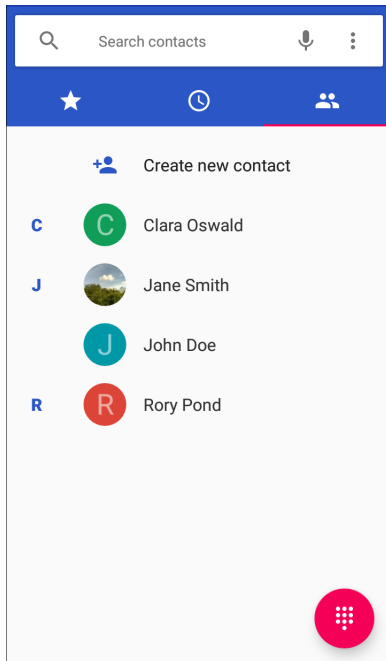

3. Touch the contact.
4. Touch  to initiate the call.
5. Touch  to end the call.

Using the Contacts App

To make a call from the Contacts app:

1. Touch .

Figure 50 Contact app



2. Touch a contact name.

Figure 51 Contact Information

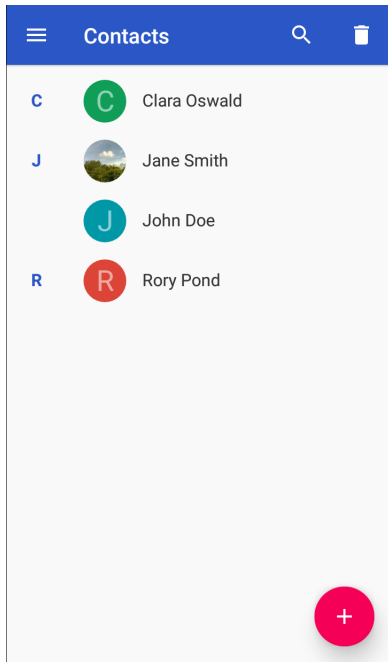
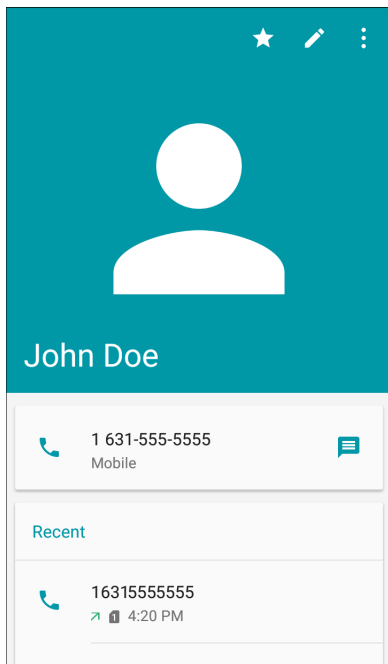

3. Touch to initiate a call.

Making a Conference Call on GSM

To create a conference phone session with multiple people.



NOTE: Conference Calling and the number of conference calls allowed may not be available on all services. Please check with the service provider for Conference Calling availability.







1. On the Home screen touch .
2. Touch .
3. Touch the keys to enter the phone number.
4. Touch  below the dialer to initiate the call.
5. When the call connects, touch .
The first call is placed on hold.
6. Touch .
7. Touch the keys to enter the second phone number.
8. Touch  below the dialer to initiate the call.
9. When the call connects, the first call is placed on hold and the second call is active.

Figure 52 Two Calls



10. Touch  icon to create a conference call with three people.

Figure 53 Merged Calls

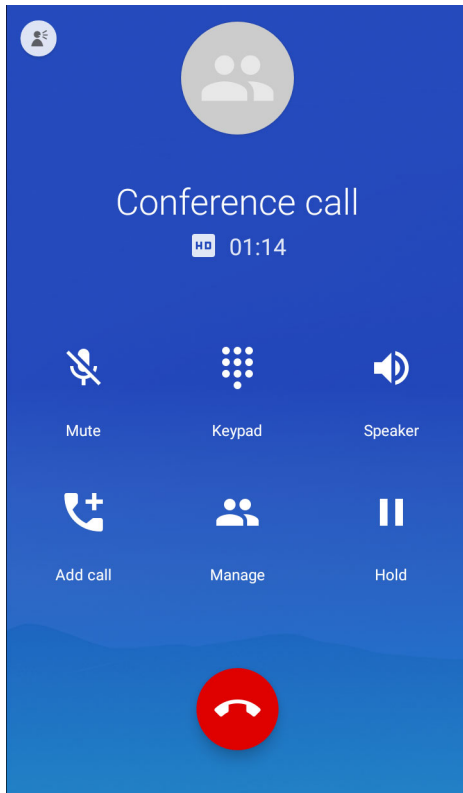



11. Touch  to add another call.

The conference is placed on hold.

12. Touch .

13. Touch the keys to enter another phone number.

14. Touch  below the dialer to initiate the call.



15. Touch  icon to add the third call to the conference.

16. Touch **Manage** to view all callers.

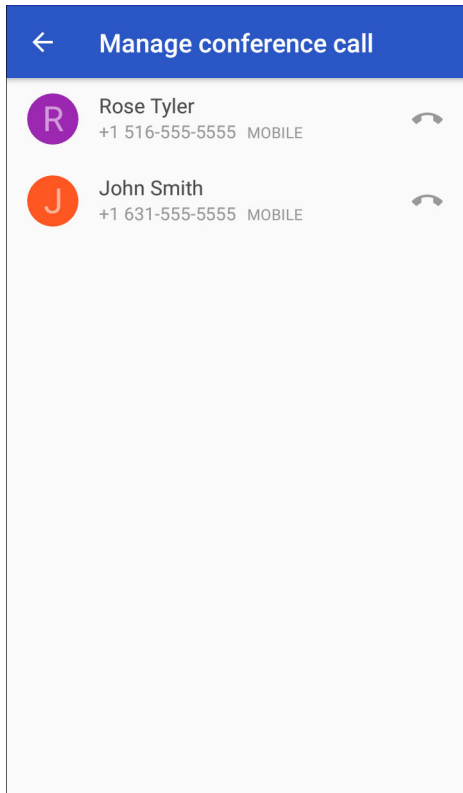
Figure 54 Un-merge Calls



17. To remove a caller from the conference, touch  next to the caller.







To speak privately with one party during a conference call, touch . To include all parties again, touch .

Making a Conference Call on GSM

To create a conference phone session with multiple people.



NOTE: Conference Calling and the number of conference calls allowed may not be available on all services. Please check with the service provider for Conference Calling availability.

1. On the Home screen touch .
2. Touch .
3. Touch the keys to enter the phone number.
4. Touch  below the dialer to initiate the call.
5. When the call connects, touch .
The first call is placed on hold.
6. Touch .
7. Touch the keys to enter the second phone number.
8. Touch  below the dialer to initiate the call.

9. When the call connects, the first call is placed on hold and the second call is active.

Figure 55 Two Calls





10. Touch  icon to create a conference call with three people.

Figure 56 Merged Calls



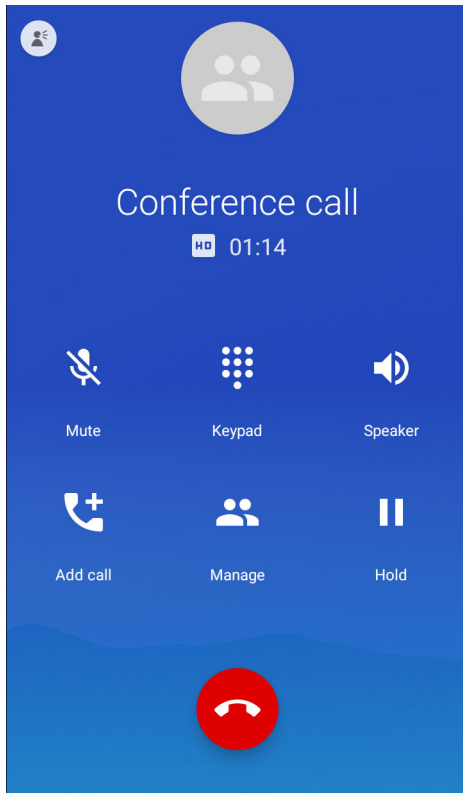

11. Touch  to add another call.

The conference is placed on hold.

12. Touch .

13. Touch the keys to enter another phone number.

14. Touch  below the dialer to initiate the call.



15. Touch  icon to add the third call to the conference.

16. Touch **Manage** to view all callers.

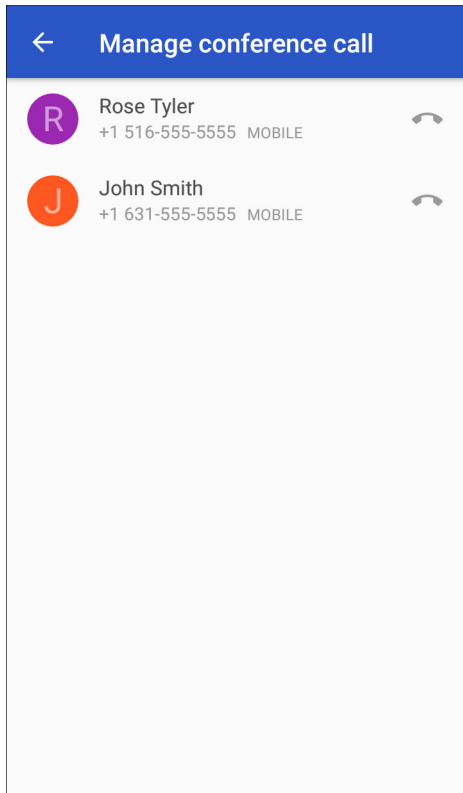
Figure 57 Un-merge Calls



17. To remove a caller from the conference, touch  next to the caller.

To speak privately with one party during a conference call, touch . To include all parties again, touch .

Making a Call Using a Bluetooth Headset

To make a call using a Bluetooth headset:

1. Pair the Bluetooth headset with the device.
2. Press the Call button on the Bluetooth headset.
3. Press the Call button on the Bluetooth headset to end the call.

Answering Calls

When receiving a phone call, the **Incoming Call** screen displays the caller ID and any additional information about the caller that is in the **Contacts** app.

Figure 58 Incoming Call Screen

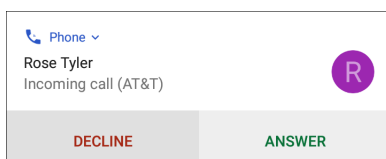



Touch **ANSWER** to answer the call or **DECLINE** to send the caller to voice mail.

If the screen lock is enabled, the user can answer the call without unlocking the device.

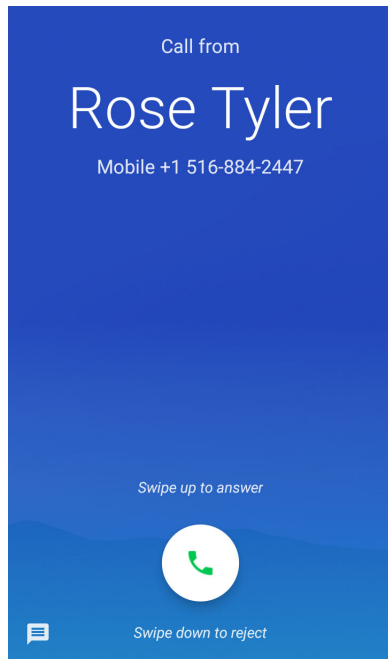
Figure 59 Incoming Call Locked Screen



When a call arrives:

- Touch  and slide up to answer the call.
- Touch  and slide down to send the call to voice mail.
- Touch  to open a list of quick text responses. Touch one to send it to the caller immediately.

When the calls ends, the device remains locked.

If using a Bluetooth headset when a call arrives, touch the Call button on the Bluetooth headset to answer the call. To end the call press the headset Call button.

All incoming calls are recorded in the Phone app Call log tab. If you miss a call, you receive a notification. To silence the ringer before answering the call, press the volume down button on the side of device.

Call Settings



NOTE: Not all options are available for all configurations

To modify phone call settings, on the Home screen touch  >  > **Settings**.

- **Display options**
 - **Sort by** - Set to **First name** or **Last name**.
 - **Name format** - Set to **First name first** or **Last name first**.

- **Sounds and vibrations**
 - **Phone ringtone** - Select a ringtone to sound when an incoming call is received.
 - **Also vibrate for calls** - Check to make the device vibrate when a call is received (default - disabled).
 - **keypad tones** - Check to play a sound when a phone key is touched (default - enabled).
 - **keypad tone length** - Set the tone length to **Normal** (default) or **Long**.
- **Quick responses** - Touch to edit quick responses to use instead of answering a call.
- **Speed dial settings** - Set speed dial contact shortcuts.
- **Calls**
 - **Calling accounts**
 - **Receive incoming calls** - Enable to allow incoming calls (default - disabled).
 - **Call forwarding** - Set to forward incoming calls to a different phone number.



NOTE: Call Forwarding may not be available on all networks. Check with the service provider for availability.

- **Additional settings**
 - **Caller ID** - Set caller ID to reveal the identity of the person making an outgoing call. Options: **Network default** (default), **Hide number**, **Show number**.
- **Call blocking** - Set to block calls and texts from certain phone numbers. Touch **ADD A NUMBER** to block a phone number.
- **Voicemail** - Configure voicemail settings.
 - **Notifications**
 - **Importance** - Set the notification importance to **Urgent**, **High** (default), **Medium**, or **Low**.
 - **Sound** - Select a sound to play when a voicemail is received.
 - **Vibrate** - Set vibrate to **On** (default) or **Off**.
 - **Advanced** - Use toggle switches to enable or disable **Blink link**, **Show notification**, or **Override Do Not Disturb**. Available options vary depending on the Importance setting.
 - **Advanced Settings**
 - **Service** - Set the service provider or other provider for voicemail service.
 - **Setup** - Select to update the phone number used to access voicemail.
- **Accessibility**
 - **TTY mode** - Touch to set the TTY setting. Use an optional teletypewriter (TTY) with the device to send and receive calls. Plug the TTY into the device headset jack and set the device to operate in one of the TTY modes.



NOTE: Use a TSB-121 compliant cable (provided by the TTY manufacturer) to connect the TTY to the device.

Set the device volume to a middle level setting for proper operation. If you experience a high number of incorrect characters, adjust the volume as needed to minimize the error rate.

For optimal performance, the device should be at least 30 cm (12 inches) from the TTY. Placing the device too close to the TTY may cause high error rates.

- **TTY off** - TTY is off (default)
- **TTY Full** - Transmit and receive TTY characters
- **TTY HCO** - Transmit TTY characters, but receive by listening to earpiece
- **TTY VCO** - Receive TTY characters, but transmit by speaking into microphone.

Applications

This section describes the applications installed on the device.

Camera

This section provides information for taking photos and recording videos using the integrated digital cameras.



NOTE: The device saves photos and videos on the microSD card, if installed and the storage path is changed manually. By default, or if a microSD card is not installed, the device saves photos and videos on the internal storage.

Taking Photos





NOTE: See Photo Settings for camera setting descriptions.

1. Swipe up from the bottom of the Home screen and touch **Camera**.

Figure 60 Camera Mode



2. If necessary, touch the Camera Mode icon and touch .
3. Frame the subject on the screen.
4. To zoom in or out, press two fingers on the display and pinch or expand fingers. The zoom controls appear on the screen.

5. Touch an area on the screen to focus. The focus circle appears. The two bars turn green when in focus.
6. Touch .

The camera takes a photo and a shutter sound plays.

The photo momentarily displays as a thumbnail in the lower left corner.



Taking a Panoramic Photo

Panorama mode creates a single wide image by panning slowly across a scene.

1. Swipe up from the bottom of the Home screen and touch **Camera**.

Figure 61 Panoramic Mode



2. Touch the Camera Mode icon and touch .
3. Frame one side of the scene to capture.
4. Touch  and slowly pan across the area to capture. A small white square appears inside the button indicating the capture is in progress.

If you are panning too quickly, the message **Too fast** appears.
5. Touch  to end the shot. The panorama appears immediately and a progress indicator displays while it saves the image.

Recording Videos

1. Swipe up from the bottom of the Home screen and touch **Camera**.

2. Touch the camera mode menu and touch .

Figure 62 Video Mode







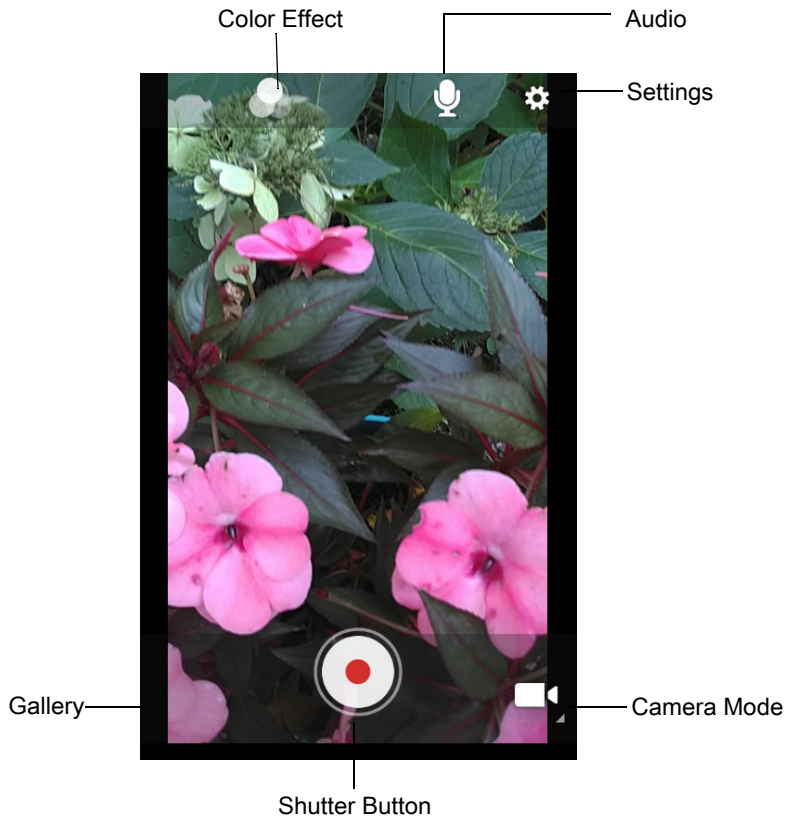





3. Point the camera and frame the scene.
4. To zoom in or out, press two fingers on the display and pinch or expand fingers. The zoom controls appear on the screen.
5. Touch  to start recording.
The video time remaining appears in the top left of the screen.
6. Touch  to the end recording.
The video momentarily displays as a thumbnail in the lower left corner.

Photo Settings

In Photo mode, photo settings appear on screen. Touch  to display the photo settings options.







Rear Camera

- **Flash** - Select whether the camera relies on its light meter to decide whether a flash is necessary, or to turn it on or off for all shots.
 -  **Off** - Disable flash.
 -  **Auto** - Adjust flash automatically depending upon light meter (default).
 -  **On** - Enable flash upon taking a photo.
- **GPS location** - Turn On or Off (default).
- **Picture size** - The size (in pixels) of the photo to: **8M pixels** (default), **5M pixels**, **4M pixels (16:9)**, **3M pixels**, **HD 1080**, **2M pixels**, **1.5M pixels**, **1.3M pixels**, **WXGA**, **HD720**, **1M pixels**, **SVGA**, **WVGA**, **720 x 480**, **VGA**, **CIF**, or **QVGA**.
- **Picture quality** - Set the picture quality setting to: **Low**, **Standard** (default) or **High**.
- **Countdown timer** - Select **Off** (default), **2 seconds**, **5 seconds** or **10 seconds**.
- **Storage** – Set the location to store the photo to: **Phone** or **SD Card**.
- **Continuous Shot** - Select to take a series of photos quickly while holding the capture button. **Off** (default) or **On**.
- **Face Detection** - Select to turn face detection **Off** (default) or **On**.
- **ZSL** - Set the camera to immediately take a picture when the button is pressed (default – enabled).
- **Anti Banding** - Select to prevent the appearance of vertical or horizontal lines (banding) when photographing images on TV and monitor screens. Options: **Off** (default), **50 Hz**, **60 Hz**, or **Auto**.
- **ISO** - Set camera sensitivity to light to: **Auto** (default), **ISO Auto (HJR)**, **ISO100**, **ISO200**, **ISO400**, **ISO800** or **ISO1600**.
- **Exposure** - Set the exposure settings to: **+2**, **+1**, **0**(default), **-1** or **-2**.
- **White balance** - Select how the camera adjusts colors in different kinds of light, to achieve the most natural-looking colors:
 -  **Incandescent** - Adjust the white balance for incandescent lighting.
 -  **Fluorescent** - Adjust the white balance for florescent lighting.
 -  **Auto** - Adjust the white balance automatically (default).
 -  **Daylight** - Adjust the white balance for daylight.
 -  **Cloudy** - Adjust the white balance for a cloudy environment.
- **Chroma Flash** - Sets the camera to take two pictures, one with flash and one without flash. The two images are combined to produce a final image with the sharpness and clarity and bright color tones from a picture with the flash, coupled with the natural colors of a picture without a flash. Options: **Off** (default) or **On**.
- **Redeye reduction** - Helps eliminate redeye effect. Options: **Disabled** (default), or **Enable**.
- **Shutter Sound** - Select to play a shutter sound when taking a photo. Options: **Disable** (default) or **Enable**.

Video Settings

In Video mode, video settings appear on screen. Touch  to display the video settings options.

Rear Camera

- **Flash** - Select whether Rear-facing Camera relies on its light meter to decide whether a flash is necessary, or to turn it on or off for all shots.
 -  **Off** - Disable flash (default).
 -  **Torch** - Turn flash on continuously.
- **Video quality** - Set video quality to: **HD 1080p** (default), **HD 720p**, **SD 480p**, **VGA**, **CIF**, or **QVGA**.
- **Video duration** - Set to: **10 minutes** (default), **30 minutes**, or **no limit**.
- **Storage** – Set the location to store the photo to: **Phone** (default) or **SD Card**.
- **White balance** - Select how the camera adjusts colors in different kinds of light, to achieve the most natural-looking colors.
 -  **Incandescent** - Adjust the white balance for incandescent lighting.
 -  **Fluorescent** - Adjust the white balance for florescent lighting.
 -  **Auto** - Adjust the white balance automatically (default).
 -  **Daylight** - Adjust the white balance for daylight.
 -  **Cloudy** - Adjust the white balance for a cloudy environment.
- **Video High FrameRate** - Select a high frame rate for videos to capture movement more clearly. Options: **Off** (default), **HFR 60**, **HFR 90**, **HFR 120**, **HSR 60**, **HSR 90**, or **HSR 120**.
- **Image Stabilization** - Set to reduce blurry videos due to device movement. Options: **On** or **Off** (default).

Contacts

Use the **Contacts** app to manage contacts.

From a Home or Apps screen, touch **Contacts** to open to the main list of contacts. Contacts are listed in alphabetical order. Swipe up or down to scroll through the list.

Adding a Contact

1. In the **Contacts** app, touch .
2. If there is more than one account with contacts, touch the one you want to use.
3. Type the contact's name and other information. Touch a field to start typing, and swipe down to view all categories.
4. To open a menu with preset labels, such as Home or Work for an email address, touch the label to the right of the item of contact information. Or, to create your own label, touch **Custom** in the menu.
5. Touch the check mark next to **Add New Contact**.

Editing Contacts

1. In the **Contacts** app, touch a contact name to edit.
2. Touch .

3. Edit the contact information.
4. Touch **SAVE**.

Deleting Contacts

1. In the **Contacts** app, touch a contact name to delete.
2. Touch .
3. Touch **Delete**.
4. Touch **DELETE** to confirm.

DataWedge Demonstration



NOTE: DataWedge is enabled on the Home screen. To disable this feature, go to the DataWedge settings and disable the **Launcher** profile.

Use **DataWedge Demonstration** to demonstrate data capture functionality.

Figure 63 DataWedge Demonstration Window

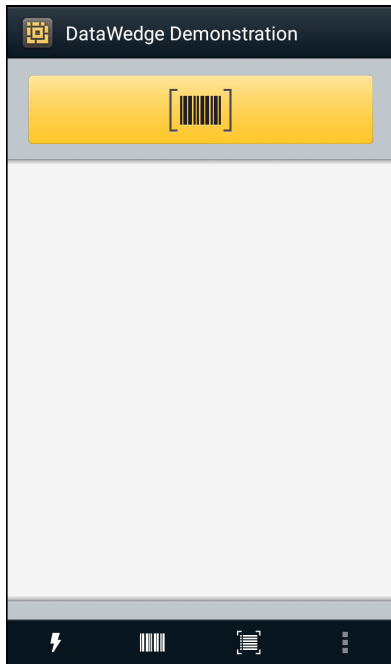

Table 9 DataWedge Demonstration Icons

	Icon	Description
Illumination		Imager illumination is on. Touch to turn illumination off.
		Imager illumination is off. Touch to turn illumination on.
Data Capture		The data capture function is through the internal imager.
		An RS507 or RS6000 Bluetooth imager is connected.
		An RS507 or RS6000 Bluetooth imager is not connected.

Table 9 DataWedge Demonstration Icons (Continued)

	Icon	Description
Scan Mode		Imager is in picklist mode. Touch to change to normal scan mode.
		Imager is in normal scan mode. Touch to change to picklist mode.
		Opens a menu to view the application information or to set the application DataWedge profile.



NOTE: See the device Integrator Guide for Android Version 8.1 for information on DataWedge configuration.

Scanner Selection

To select a scanner, touch > **Settings** > **Scanner selection**.

See Data Capture for more information.

Either press the programmable button or touch the yellow scan button to capture data. The data appears in the text field below the yellow button.

Diagnostic Tool

The **Diagnostic Tool** is a utility that determines the health of the device. Use the Diagnostic Tool to troubleshoot the device.

1. Swipe up from the bottom of the Home screen and touch .

Figure 64 Diagnostic Tool

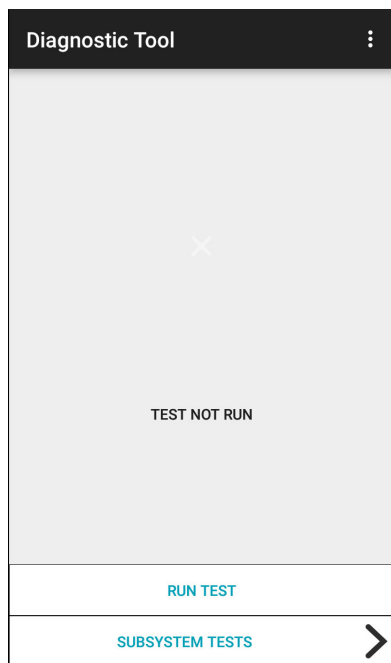

2. Touch **RUN TEST**. The app tests all enabled subsystems (by default, only the Battery and System tests). See Settings to enable subsystem tests.

Figure 65 Test Passed Screen

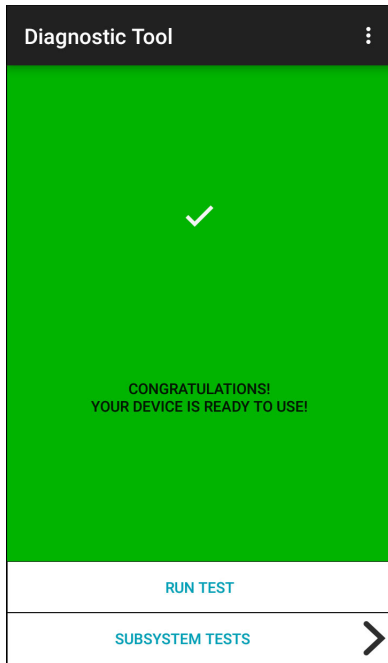
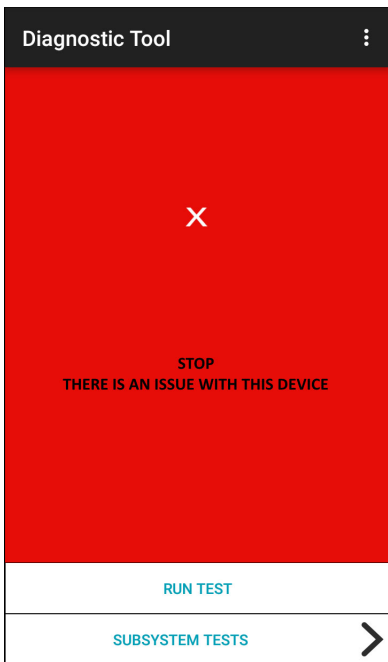
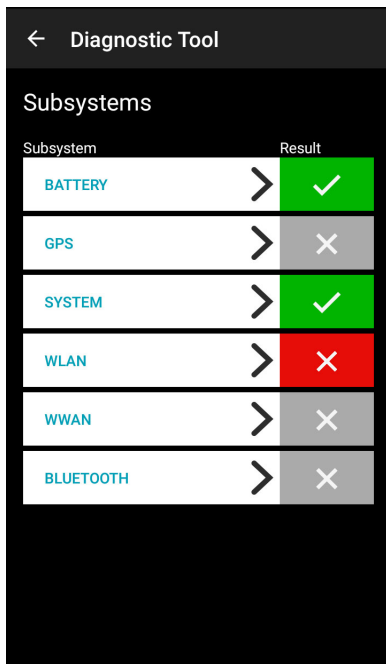

Figure 66 Test Failed Screen



3. To view each subsystem test, touch **Subsystem Tests**.

Figure 67 Subsystem Screen



4. Touch one of the subsystems to view details.

Table 10 Subsystem Test Result Indicators



Status Icon	Description
	Test passed.
	Test failed.
	Test not supported or not enabled.

Figure 68 Battery Subsystem Details



Settings

By default only the Battery and System tests are enabled. To enable other tests:

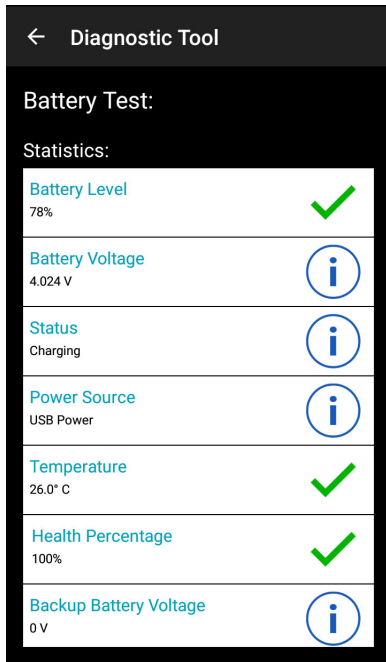
1. Touch **☰** > **Settings**.
2. Touch to the left of the test name. A green box with a checkmark appears.
3. Touch **SAVE**.
4. Touch **Yes** to confirm.
5. Touch **◀**.

Battery Test Information

The Battery Test obtains the following information:

- **Battery Level** - Current battery charge level
- **Battery Voltage** - Current battery voltage
- **Status** - Whether the battery is charging (on AC power) or discharging (on battery power)
- **Power Source** - Whether the device is receiving power from the battery or from an external source
- **Temperature** - Current battery temperature
- **Health Percentage** - Indicates the ratio of present capacity to design capacity at a discharge rate of design capacity.
- **Backup Battery Voltage** - Backup battery voltage.
- **Manufacture Date** - Manufacture date of the battery.

GPS Test Information

The GPS Test obtains the following information (WWAN only):

- **GPS Provider Enabled** - Whether GPS is enabled (true) or disabled (false)
- **Latitude** - Current latitude position
- **Longitude** - Current longitude position
- **Altitude** - Current altitude in meters
- **Bearing** - Current bearing
- **Speed** - Speed in meters per second
- **Accuracy** - GPS accuracy in meters.

System Test Information

Use the System Test to determine if the CPU or memory loads are too high, there are too many processes running on the device, or storage on the device is almost full.

The System Test obtains the following information:

- **CPU Load** - Amount of CPU being used
- **Free Physical Memory** - Amount of RAM available
- **Free Storage** - Amount of internal Flash memory available
- **Process Count** - Number of processes currently running.

WLAN Test Information

If the WiFi radio is not present or disabled, skip this test. This test determines if the device's WLAN configuration is correct or whether there is any connection with an access point or network.

The WLAN test obtains the following information:

- **WLAN Enabled** - WLAN radio is enabled or disabled
- **WLAN Status** - Current status of association with the access point
- **ESSID** - Name of the wireless network
- **BSSID** - MAC address of the connected access point
- **MAC Address** - Device's MAC address
- **Signal** - Strength of the Wi-Fi signal (in dBm)
- **IP Address** - IP address of the device.

WWAN Test Information

The WWAN Test obtains the following information (WWAN only):

- **SIM State** - Current state of the SIM card
- **WAN Type** - Data connection type
- **Signal Strength** - Current cellular signal strength
- **Phone Number** - Phone number assigned to the device

- **Device ID** - Device ID number.

Bluetooth Test Information

The Bluetooth Test obtains the following information:

- **Enabled** - Whether the Bluetooth radio is enabled or disabled
- **Status** - Whether the device is paired to another Bluetooth device
- **Connectable/Discoverable** - Whether the device is discoverable or able to connect
- **Address** - Bluetooth radio MAC address
- **Name** - Bluetooth name for the device.

Files

Use the **Files** app to view and manage files on the device.







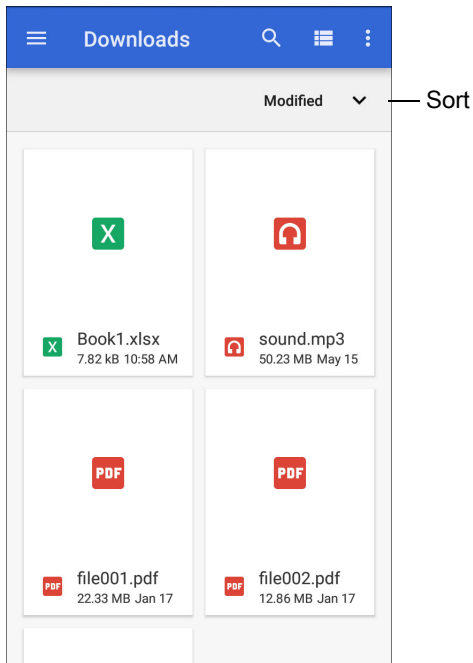

To open **Files**, swipe up from the bottom of the screen and touch .

Figure 69 Files Screen



- Touch and hold an item to open the File Operations menu. Select an option:
 -  - Share the file with other devices.
 -  - Delete the file.
 -  - View additional options.
 - **Open with** - Select which app is used to open the file.
 - **Select all** - Select all folders and files.
 - **Copy to...** - Copy the file.
 - **Move to...** - Move the file or folder to a new location.
 - **Compress** - Compress the selected file(s) into a ZIP file.
 - **Rename** - Rename the file.
- Touch the Sort drop-down to sort files by name, type, size, or date.
-  - View all file locations.
-  - Search for a specific file on the device.
-  /  - Change the folder to display items as a list / grid.
-  - Open the options menu.
 - **New Window** - Create a new Files window.
 - **New Folder** - Create a new folder.
 - **Select all** - Select all folders and files.
 - **Show/Hide internal storage** - Show or hide internal storage.

Gallery



NOTE: The device supports the following image formats: jpeg, gif, png and bmp.

The device supports the following video formats: H.263, H.264 and MPEG4 Simple Profile.

Available on device with AOSP only.

Use Gallery to:

- View photos
- Play videos
- Perform basic editing of photos
- Set photos as wallpaper
- Set photos as a contact photo
- Share photos and videos.

Gallery presents all photos and videos stored on the microSD card and internal memory.

To open **Gallery**, swipe up from the bottom of the Home screen and touch **Gallery**, or in the camera app touch the thumbnail image at the bottom left.

By default, **Gallery** opens to the **Timeline** view.

Figure 70 Gallery - Timeline View







Touch  > **Albums** to view photos sorted by albums or  > **Videos** to view only videos.

Figure 71 Gallery — Albums View

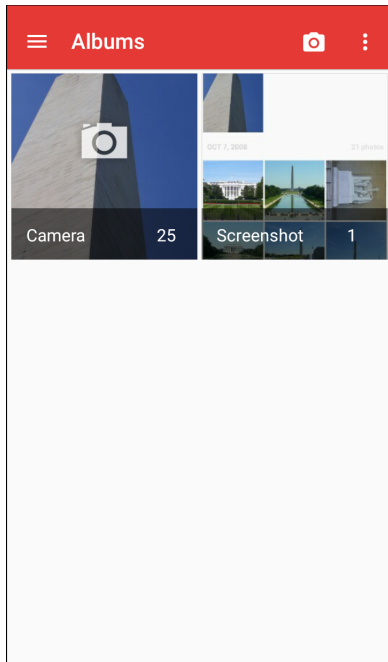

- Touch an album to open it and view its contents. The photos and videos in the album are displayed in chronological order.
- Touch a photo or video in an album to view it.
- Touch  > **Timeline** to return to the default **Gallery** screen.

Working with Albums

Albums are groups of images and videos in folders. Touch an album to open it. The photos and videos are listed in a chronologically ordered grid. The name of the album displays at the top of the screen.

Figure 72 Photos Inside an Album

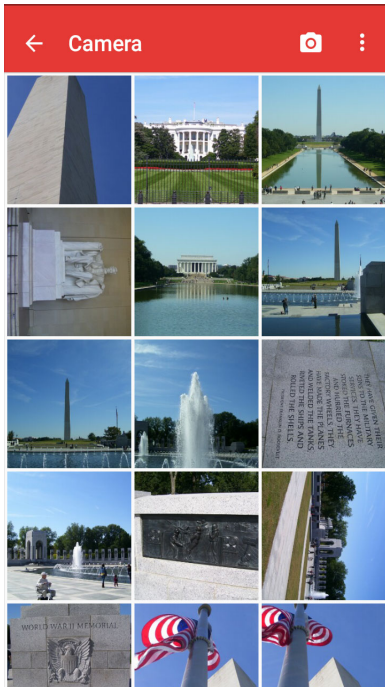

Swipe up or down to scroll through the images.

Sharing an Album

1. Swipe up from the bottom of the Home screen and touch **Gallery**.
2. Touch and hold an album to highlight it.
3. Touch other albums as required.
4. Touch . The Share menu opens.
5. Touch the app to use to share the selected albums.
6. Follow the instructions within the selected app.

Getting Album Information

1. Swipe up from the bottom of the Home screen and touch **Gallery**.
2. Touch and hold an album to highlight it.
3. Touch .
4. Touch **Details**.

Deleting an Album

To delete an album and its contents:

1. Swipe up from the bottom of the Home screen and touch **Gallery**.
2. Touch and hold an album to highlight it.
3. Check other albums to delete.

4. Touch .
5. In the **Delete selected item?** menu, touch **OK** to delete the album.

Working with Photos

Use **Gallery** to view photos on the device and edit and share photos.

Cropping a Photo





1. In **Gallery**, touch a photo to view the controls.
2. Touch  >  > . The cropping tool appears.
3. Use the cropping tool to select the portion of the photo to crop.
 - Drag from the inside of the cropping tool to move it.
 - Drag an edge of the cropping tool to resize it to any proportion.

Figure 73 Cropping Tool

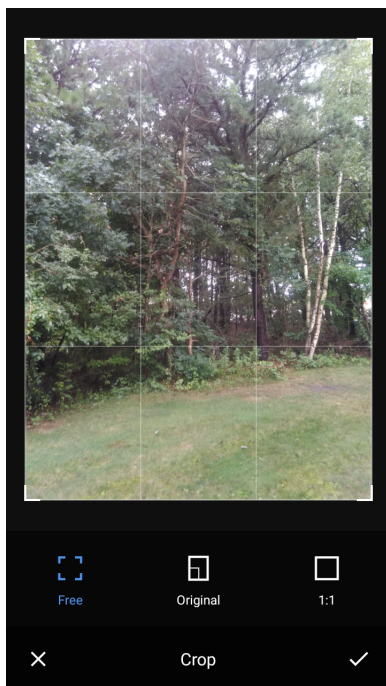

4. Touch  > **SAVE** to save a copy of the cropped photo. The original version is retained.

Setting a Photo as a Contact Icon

1. Swipe up from the bottom of the Home screen and touch **Gallery**.
2. Touch an album to open it.
3. Touch a photo to open it.
4. Touch .
5. Touch **Set picture as**.

6. Touch **Contact photo**.
7. In **Contacts**, touch a contact.
8. Touch the white box and crop the photo accordingly.
9. Touch **SAVE**.

Sharing a Photo

1. Swipe up from the bottom of the Home screen and touch **Gallery**.
2. Touch an album to open it.
3. Touch a photo to open it.
4. Touch .
5. Touch the app to use to share the selected photo.
6. Follow the instructions within the selected app.

Deleting a Photo

1. Swipe up from the bottom of the Home screen and touch **Gallery**.
2. Touch an album to open it.
3. Touch a photo to open it.
4. Touch .
5. Touch **OK** to delete the photo.

Working with Videos

Use **Gallery** to view and share videos.

Watching Videos

1. Swipe up from the bottom of the Home screen and touch **Gallery**.
2. Touch an album to open it.
3. Touch a video.
4. Touch  to play.
5. Touch the screen to view the playback controls.

Sharing a Video

1. Swipe up from the bottom of the Home screen and touch **Gallery**.
2. Touch an album to open it.
3. Touch a video to open it.
4. Touch . The Share menu appears.
5. Touch the app to use to share the selected video.

6. Follow the instructions within the selected app.

Deleting a Video

1. Swipe up from the bottom of the Home screen and touch **Gallery**.
2. Touch an album to open it.
3. Touch a video to open it.
4. Touch .
5. Touch **OK**.

Photos



NOTE: The device supports the following image formats: jpeg, gif, png, and bmp.

The device supports the following video formats: H.263, H.264, and MPEG4 Simple Profile.

Available on device with GMS only.

Use **Photos** to:

- View photos
- Play videos
- Perform basic editing of photos
- Set photos as wallpaper
- Set photos as a contact photo
- Share photos and videos.

Photos presents all photos and videos stored on the microSD card and internal memory.

To open **Photos**, swipe up from the bottom of the Home screen and touch **Photos**.

By default, **Photos** opens to the photos view.

Figure 74 Photos View

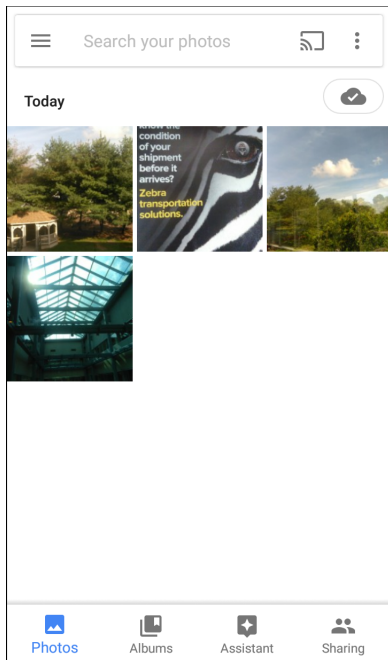

Touch **Albums** to view photos sorted by albums.

Figure 75 Albums View

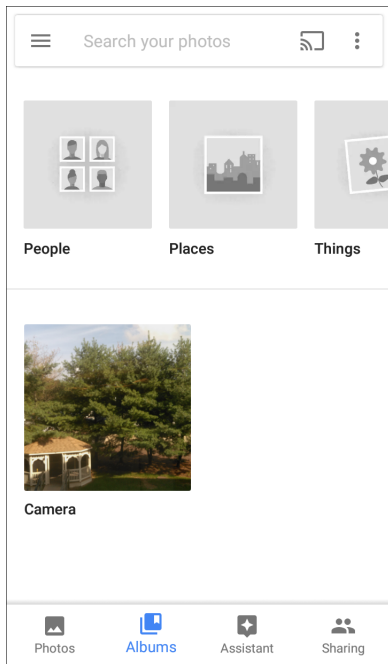

- Touch an album to view its contents. The photos and videos in the album appear in chronological order.
- Touch a photo or video in an album to view it.
- Touch ← to return to the main screen.

Working with Albums

Albums are groups of images and videos in folders. Touch an album to open it. The photos and videos are listed in a chronologically ordered grid. The name of the album displays at the top of the screen.

Figure 76 Photos Inside an Album

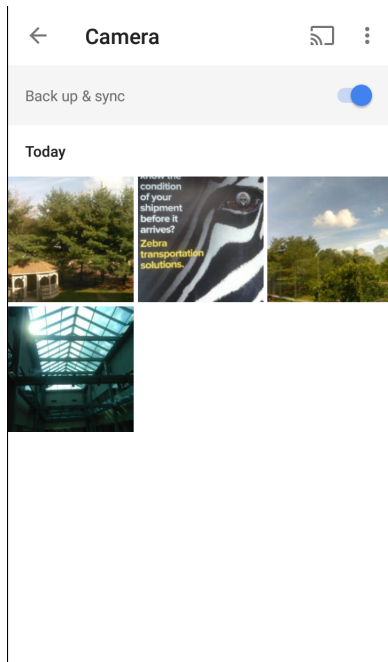

Swipe up to scroll through the images.

Deleting an Album

To delete an album and its contents:

1. Swipe up from the bottom of the Home screen and touch **Photos**.
2. Touch **Albums**.
3. Touch an album.
4. Touch **⋮** > **Select**.
5. Select all photos in the album.
6. Touch **🗑️**.
7. Touch **Move to trash** to delete the album.

Working with Photos

Use **Photos** to view photos on the internal memory and the microSD card.

Viewing and Browsing Photos

1. Swipe up from the bottom of the Home screen and touch **Photos**.
2. Touch a photo.

Figure 77 Photo Example

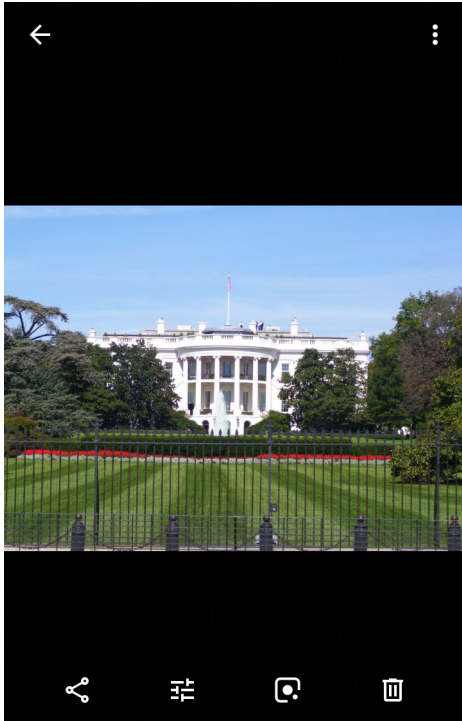

3. Swipe left or right to view the next or previous photo in the album.
4. Turn the device to view the photo in upright (portrait) or sideways (landscape) orientation. The photo is displayed (but not saved) in the new orientation.
5. Touch the photo to view the controls.
6. Double-tap the screen to zoom in, or pinch two fingers together or spread them apart to zoom in or out.
7. Drag the photo to view parts that are not in view.

Cropping a Photo



1. Swipe up from the bottom of the Home screen and touch **Photos**.
2. Touch a photo to view the controls.
3. Touch  > . The cropping tool appears.

Figure 78 Cropping Tool



4. Use the cropping tool to select the portion of the photo to crop.
 - Drag from the inside of the cropping area to move it.
 - Drag an edge of the cropping area to resize it to any proportion.
5. Touch **DONE**.
6. Touch **SAVE** to save a copy of the cropped photo. The original version is retained.

Setting a Photo as a Contact Icon

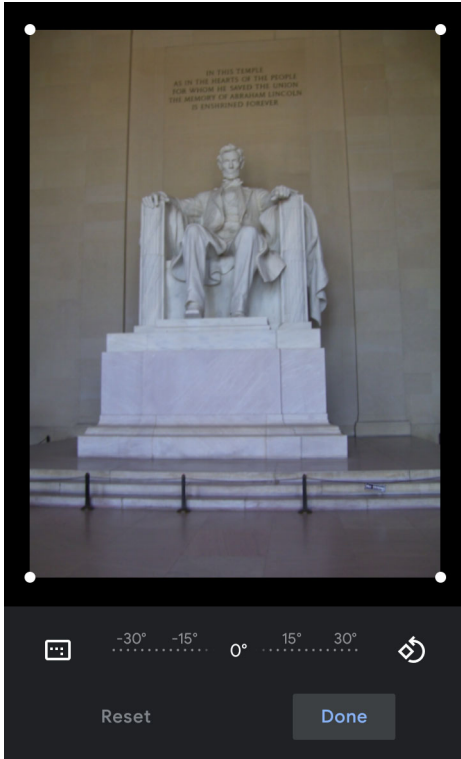
1. Swipe up from the bottom of the Home screen and touch **Photos**.
2. Touch the photo to open it.
3. Touch **⋮** > **Use as**.
4. Touch **Contact photo**.
5. In the **Contacts** app, touch a contact.
6. Touch the white box and crop the photo accordingly.
7. Touch **Done**.

Sharing a Photo

1. Swipe up from the bottom of the Home screen and touch **Photos**.
2. Touch an album to open it.
3. Touch a photo to open it.
4. Touch **🔗**.

5. Touch the app to use to share the selected photo.
6. Follow the instructions within the selected app.

Deleting a Photo

1. Swipe up from the bottom of the Home screen and touch **Photos**.
2. Touch a photo to open it.
3. Touch .
4. Touch **MOVE TO TRASH**.

Working with Videos

Use **Photos** to view and share videos.

Watching a Video

1. Swipe up from the bottom of the Home screen and touch **Photos**.
2. Touch a video to play.
3. Touch the screen to view the playback controls.

Sharing a Video

1. Swipe up from the bottom of the Home screen and touch **Photos**.
2. Touch a video to open it.
3. Touch . The Share menu appears.
4. Touch the app to use to share the selected video.
5. Follow the instructions within the selected app.

Deleting a Video

1. Swipe up from the bottom of the Home screen and touch **Photos**.
2. Touch a video to open it.
3. Touch .
4. Touch **MOVE TO TRASH** to delete the video.

PTT Express Voice Client



NOTE: PTT Express Voice Client enables Push-To-Talk (PTT) communication between disparate enterprise devices. Leveraging existing Wireless Local Area Network (WLAN) infrastructure, PTT Express delivers simple PTT communication without requiring voice communication server.

- **Group Call:** Press and hold the PTT (Talk) button to start communicating with other voice client users.
- **Private Response:** Double-press the PTT button to respond to the originator of the last broadcast or to make a Private Response.

PTT Audible Indicators

The following tones provide helpful cues when using the voice client.

- **Talk Tone:** Double chirp. Plays when the Talk button is depressed. This is a prompt for you to start talking.
- **Access Tone:** Single beep. Plays when another user just finished a broadcast or response. You can now initiate a Group Broadcast or Private Response.
- **Busy Tone:** Continuous tone. Plays when the Talk button is depressed and another user is already communicating on the same talkgroup. Plays after the maximum allowed talk time is reached (60 seconds).
- **Network Tone:**
 - Three increasing pitch beeps. Plays when PTT Express acquires the WLAN connection and the service is enabled.
 - Three decreasing pitch beeps. Plays when PTT Express loses the WLAN connection or the service is disabled.



PTT Notification Icons

Notification icons indicate the current state of the PTT Express Voice client.

Table 11 PTT Express Icon Descriptions

Status Icon	Description
	The PTT Express Voice client is disabled.
	The PTT Express Voice client is enabled but not connected to a WLAN.
	The PTT Express Voice client is enabled, connected to a WLAN, and listening on the Talk Group indicated by the number next to the icon.
	The PTT Express Voice client is enabled, connected to a WLAN, and communicating on the Talk Group indicated by the number next to the icon.
	The PTT Express Voice client is enabled, connected to a WLAN, and in a private response.

Table 11 PTT Express Icon Descriptions (Continued)

Status Icon	Description
	The PTT Express Voice client is enabled and muted.
	The PTT Express Voice client is enabled but it is not able to communicate due to a VoIP telephony call in progress.

Enabling PTT Communication

1. Swipe up from the bottom of the Home screen and touch .
2. Slide the **Enable/Disable Switch** to the **ON** position. The button changes to **ON**.

Selecting a Talk Group

One of 32 Talk Groups can be selected by PTT Express users. However, only one talk group may be enabled at a time on the device. Touch one of the 32 Talk Groups. The selected Talk Group is highlighted.

PTT Communication



NOTE: This section describes the default PTT Express client configuration. See the PTT Express V1.2 User Guide for detailed information on using the client.

PTT communication may be established as a Group Call. When PTT Express is enabled, the PTT button on the left side of the device is assigned for PTT communication.

Figure 79 PTT Button

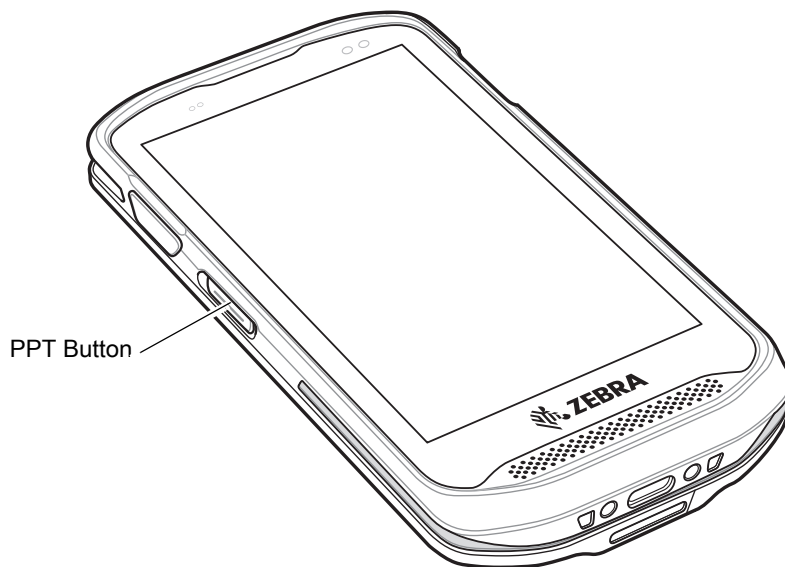

Creating a Group Call

1. Press and hold the PTT button and listen for the talk tone.

If you hear a busy tone, release the button and wait a moment before making another attempt. Ensure that PTT Express and the WLAN are enabled.

2. Start talking after hearing the talk tone.





NOTE: Holding the button for more than 60 seconds (default) drops the call, allowing others to make Group calls. Release the button when finished talking to allow others to make calls.

Responding with a Private Response

The Private Response can only be initiated once a Group Call has been established. The initial Private Response is made to the originator of the Group Call.

1. Wait for an access tone.
2. Within 10 seconds, double-press the PTT button, and listen for the talk tone.
3. If you hear a busy tone, release the button and wait a moment before making another attempt. Ensure that PTT Express and the WLAN are enabled.
4. Start talking after the talk tone plays.
5. Release the button when finished talking.

Disabling PTT Express Voice Client Communication

1. Swipe up from the bottom of the Home screen and touch .
2. Slide the **Enable/Disable Switch** to the **OFF** position. The button changes to **OFF**.
3. Touch .

RxLogger

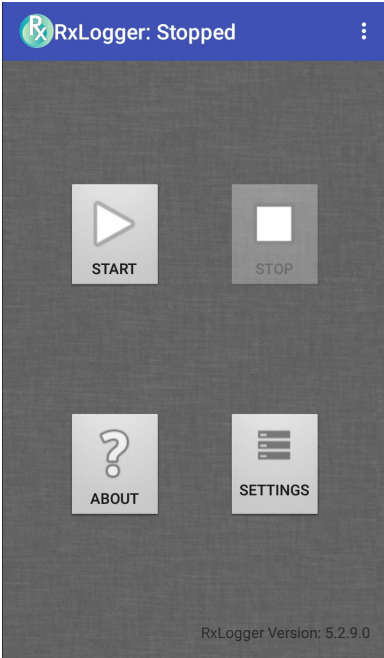

RxLogger is a comprehensive diagnostic tool that provides app and system metrics. Create custom plug-ins that work seamlessly with this tool. RxLogger diagnoses device and application issues, and tracks information for: CPU load, memory load, memory snapshots, battery consumption, power states, wireless logging, TCP dumps, Bluetooth logging, GPS logging, logcat, ANR dumps, etc. All logs and files generated are saved in flash storage on the device (internal or external).

Figure 80 RxLogger





Enabling Logging

To enable RxLogger:

1. Swipe up from the bottom of the Home screen and touch .
2. Touch **START**. RxLogger begins collecting data.
3. Touch .

Disabling Logging

To disable RxLogger:

1. Swipe up from the bottom of the Home screen and touch .
2. Touch **STOP**. RxLogger stops collecting data.
3. Touch .

RxLogger Utility

RxLogger Utility is a data monitoring application for viewing logs in the device while RxLogger is running. Access the logs and RxLogger Utility features in the App View or the Overlay View.

In the App View, view logs in the RxLogger Utility.

Figure 81 RxLogger Utility App View

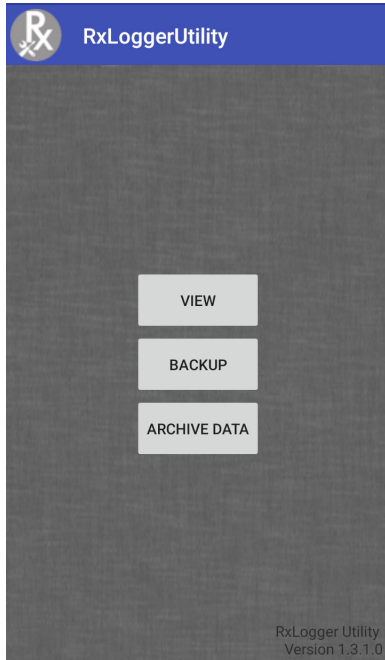

Refer to the device Integrator Guide for detailed information on the RxLogger Utility.

Sound Recorder

Use **Sound Recorder** to record audio messages.

Recordings are saved on the microSD card (if installed) or the internal storage and are available in the Music application (non-GMS devices) or the Play Music application (GMS devices).

Figure 82 Sound Recorder Application

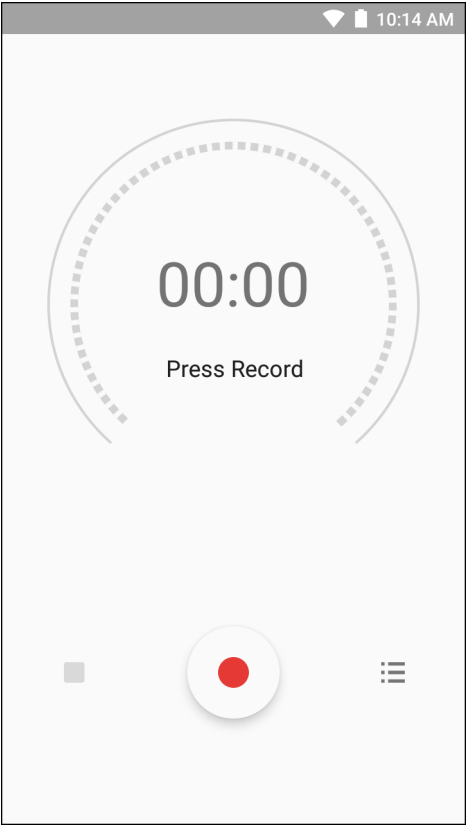

Data Capture

The device supports data capture using:

- integrated imager
 - SE4710 scan engine
 - SE2100 scan engine
- RS507 Hands-free Imager
- RS6000 Bluetooth Ring Scanner.



IMPORTANT: To determine the integrated scan engine in the device, go to **Settings >System > About phone > Hardware components > Scanner**.

Imaging

The imager uses imaging technology to take a picture of a bar code, stores the resulting image in its memory, and executes state-of-the-art software decoding algorithms to extract the bar code data from the image. With a 2D imager, the device has the following features:

- Omnidirectional reading of a variety of bar code symbologies, including the most popular linear, postal, PDF417, and 2D matrix code types.
- Advanced intuitive laser aiming cross-hair and dot aiming for easy point-and-shoot operation.

Operational Modes

The device with an integrated imager supports two modes of operation, listed below. Activate each mode by pressing the Scan button.

- **Decode Mode:** In this mode, the device attempts to locate and decode enabled barcodes within its field of view. The imager remains in this mode as long as the user holds the scan button, or until it decodes a barcode.



NOTE: To enable Pick List Mode, configure in DataWedge or set in an application using a API command.

- **Pick List Mode:** This mode allows the user to selectively decode a barcode when more than one barcode is in the device's field of view. To accomplish this, move the aiming crosshair or dot over the required barcode to decode only this barcode. This feature is ideal for pick lists containing multiple barcodes and manufacturing or transport labels containing more than one barcode type (either 1D or 2D).



NOTE: To enable Basic MultiBarcode Mode, configure in DataWedge or set in an application using a API command.

- **Basic MultiBarcode Mode:** In this mode, the device attempts to locate and decode a specific number of unique barcodes within its field of view. The device remains in this mode as long as the user holds the scan button, or until it decodes all the barcodes. Available on integrated SE2100 or SE4710 imagers only.
 - The device attempts to scan the programmed number of unique barcodes (from 2 through 10).
 - If there are duplicate barcodes (same symbology type and data), only one of the duplicate barcodes is decoded and the remainder are ignored. If the label has two duplicate barcodes plus another two different barcodes, a maximum of three barcodes will be decoded from that label; one will be ignored as a duplicate.
 - Barcodes can be of multiple symbology types and still be acquired together. For example, if the specified quantity for a Basic MultiBarcode scan is four, two barcodes can be symbology type Code 128 and the other two can be symbology type Code 39.
 - If the specified number of unique barcodes is not initially in view of the device, the device will not decode any data until the device is moved to capture the additional barcode(s) or time out occurs. If the device field of view contains a number of barcodes greater than the specified quantity, the device randomly decodes barcode(s) until the specified number of unique barcodes is reached. For example, if the count is set to two and eight barcodes are in the field of view, the device decodes the first two unique barcodes it sees, returning the data in random order.
 - Basic MultiBarcode Mode does not support concatenated barcodes.

RS507/RS507x Hands-Free Imager

The RS507 and RS507x Hands-free Imagers are wearable barcode scan solution for both 1D and 2D bar code symbologies. The scanner supports Bluetooth Human Interface Device (HID) connection to the device.

Figure 83 RS507/RS507x Hands-Free Imager

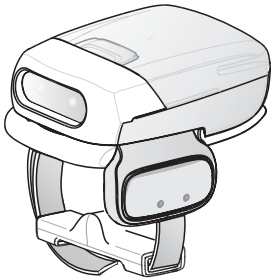

Refer to the RS507/RS507x Hands-free Imager Product Reference Guide for more information.

RS6000 Bluetooth Ring Scanner

The RS6000 Bluetooth Ring Scanner is a wearable bar code scan solution for both 1D and 2D bar code symbologies.

Figure 84 RS6000 Bluetooth Ring Scanner

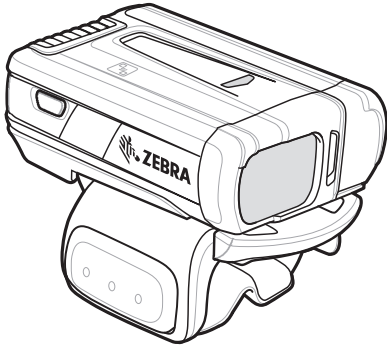

Refer to the RS6000 Bluetooth Ring Scanner Product Reference Guide for more information.

Scanning Considerations

Typically, scanning is a simple matter of aim, scan, and decode, with a few quick trial efforts to master it. However, consider the following to optimize scanning performance:

- **Range:** Scanners decode best over a particular working range — minimum and maximum distances from the barcode. This range varies according to barcode density and scanning device optics. Scan within range for quick and constant decodes; scanning too close or too far away prevents decodes. Move the scanner closer and further away to find the right working range for the barcodes being scanned.
- **Angle:** Scanning angle is important for quick decodes. When the illumination/flash reflects directly back into the imager, the specular reflection can blind/saturate the imager. To avoid this, scan the barcode so that the beam does not bounce directly back. Do not scan at too sharp an angle; the scanner needs to collect scattered reflections from the scan to make a successful decode. Practice quickly shows what tolerances to work within.
- Hold the device farther away for larger symbols.
- Move the device closer for symbols with bars that are close together.



NOTE: Scanning procedures depend on the app and device configuration. An app may use different scanning procedures from the one listed above.

Barcode Scanning with Internal SE2100 Imager

To read a barcode, a scan-enabled application is required. The device contains the DataWedge application that allows the user to enable the imager, decode the barcode data and display the barcode content.

1. Ensure that an application is open on the device and a text field is in focus (text cursor in text field).

2. Point the exit window on the top of the device at a barcode.

Figure 85 SE2100 Imager Scanning

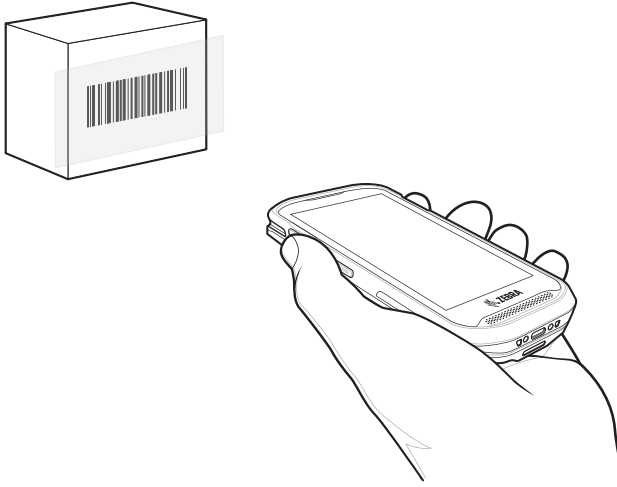

3. Press and hold the scan button.
The white aiming pattern turns on to assist in aiming.
4. Ensure the barcode is within the area formed by the aiming pattern.

Figure 86 SE2100 Aiming Pattern



5. The Data Capture LED lights green and a beep sounds, by default, to indicate the barcode was decoded successfully.
6. Release the scan button.



NOTE: Imager decoding usually occurs instantaneously. The device repeats the steps required to take a digital picture (image) of a poor or difficult barcode as long as the scan button remains pressed.

7. The barcode content data displays in the text field.

SE2100 Picklist Mode

When Picklist Mode is enabled, the screen displays an image of the barcode and a red cross-hair. See TC20 Mobile Computer Integrator Guide for Android 8.0 Oreo for information on setting Picklist Mode.

When the device is in Picklist Mode, the imager does not decode the barcode until the cross-hair touches the barcode.

Figure 87 SE2100 Pick List Mode with Multiple Barcodes in Aiming Pattern

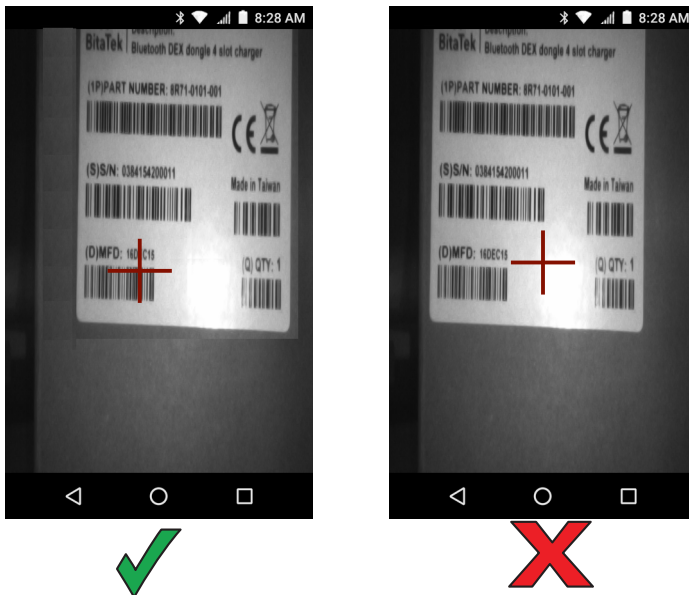

SE2100 Basic MultiBarcode Mode

To read multiple barcodes, a scan-enabled application is required. The device contains the DataWedge application that allows the user to enable the imager, decode the barcode data and display the barcode content.

1. Ensure that an application is open on the device and a text field is in focus (text cursor in text field).
2. Point the exit window on the top of the device at the barcodes.
3. Press and hold the scan button.
The white aiming pattern turns on to assist in aiming.
4. Ensure the barcodes are within the area formed by the aiming pattern.

Figure 88 SE2100 Aiming Pattern with Multiple Barcodes



5. The Data Capture LED lights green and a beep sounds, by default, to indicate the barcode was decoded successfully. Captured data from all barcodes is delivered as a single string.
6. Release the scan button.



NOTE: Imager decoding usually occurs instantaneously. The device repeats the steps required to take a digital picture (image) of a poor or difficult barcode as long as the scan button remains pressed.

7. The barcode content data displays in the text field.

Barcode Scanning with Internal SE4710 Imager

To read a barcode, a scan-enabled application is required. The device contains the DataWedge application that allows the user to enable the imager, decode the barcode data and display the barcode content.

1. Ensure that an application is open on the device and a text field is in focus (text cursor in text field).
2. Point the exit window on the top of the device at a barcode.

Figure 89 SE4710 Imager Scanning

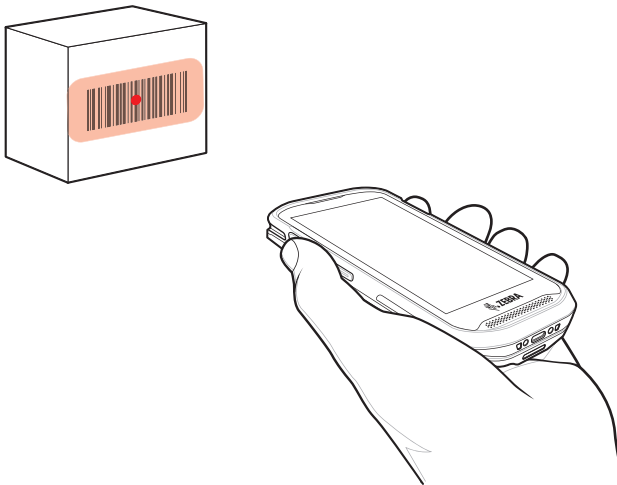

3. Press and hold the scan button.

The red LED aiming pattern turns on to assist in aiming.



NOTE: When the device is in Picklist mode, the imager does not decode the barcode until the crosshair or aiming dot touches the barcode.

4. Ensure the barcode is within the area formed by the aiming pattern. The aiming dot is used for increased visibility in bright lighting conditions.

Figure 90 SE4710 Aiming Pattern

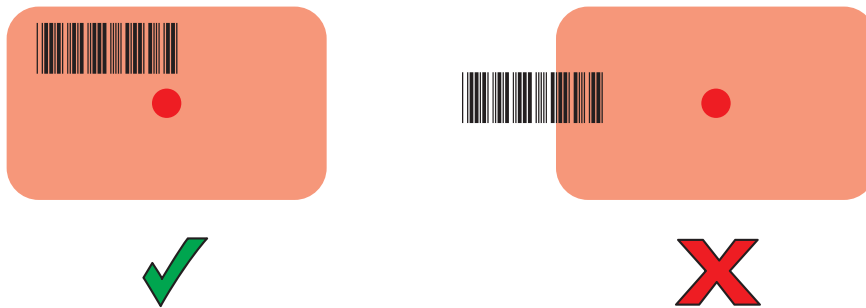
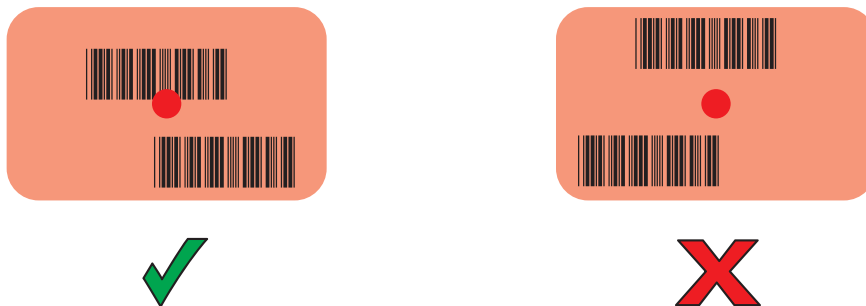

Figure 91 SE4710 Pick List Mode with Multiple barcodes in Aiming Pattern



5. The Data Capture LED lights green and a beep sounds, by default, to indicate the barcode was decoded successfully.
6. Release the scan button.



NOTE: Imager decoding usually occurs instantaneously. The device repeats the steps required to take a digital picture (image) of a poor or difficult barcode as long as the scan button remains pressed.

7. The barcode content data displays in the text field.

SE4710 Basic MultiBarcode Mode

To read multiple barcodes, a scan-enabled application is required. The device contains the DataWedge application that allows the user to enable the imager, decode the barcode data and display the barcode content.

1. Ensure that an application is open on the device and a text field is in focus (text cursor in text field).
2. Point the exit window on the top of the device at the barcodes.
3. Press and hold the scan button.
The red LED aiming pattern turns on to assist in aiming.

4. Ensure the barcodes are within the area formed by the aiming pattern. The aiming dot is used for increased visibility in bright lighting conditions.

Figure 92 SE4710 Aiming Pattern with Multiple Barcodes

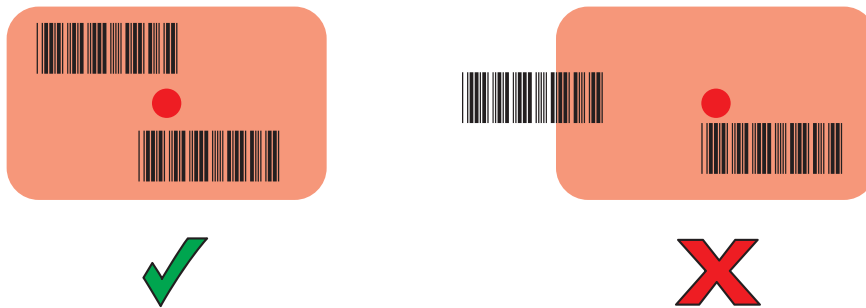

5. The Data Capture LED lights green and a beep sounds, by default, to indicate the barcode was decoded successfully. Captured data from all barcodes is delivered as a single string.
6. Release the scan button.



NOTE: Imager decoding usually occurs instantaneously. The device repeats the steps required to take a digital picture (image) of a poor or difficult barcodes as long as the scan button remains pressed.

7. The barcodes content data displays in the text field.

Scanning with RS6000 Bluetooth Ring Scanner

To read a barcode, a scan-enabled app is required. Devices that contain the Zebra DataWedge app allows you to enable the scanner to decode barcode data and display the barcode content.

To scan with the RS6000:

1. Pair the RS6000 with the device. See Pairing Using Bluetooth Human Interface Device for more information.
2. Ensure that an app is open on the device and a text field is in focus (text cursor in text field).
3. Point the RS6000 at a barcode.

Figure 93 Barcode Scanning with RS6000

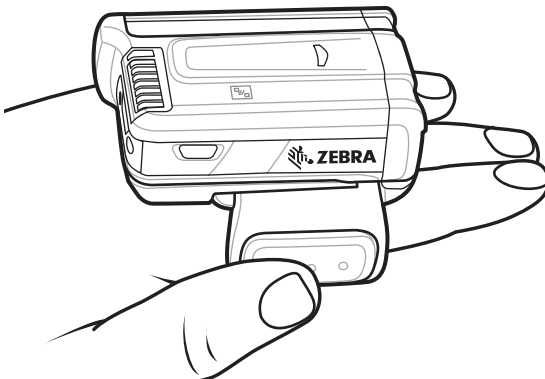

4. Press and hold the trigger.

The red laser aiming pattern turns on to assist in aiming. Ensure the barcode is within the area formed by the cross-hairs in the aiming pattern. The aiming dot increases visibility in bright lighting conditions.

The RS6000 LEDs light green and a beep sounds to indicate the barcode was decoded successfully. When the RS6000 is in Pick List mode, the RS6000 does not decode the barcode until the center of the crosshair touches the barcode.

Figure 94 RS6000 Aiming Pattern

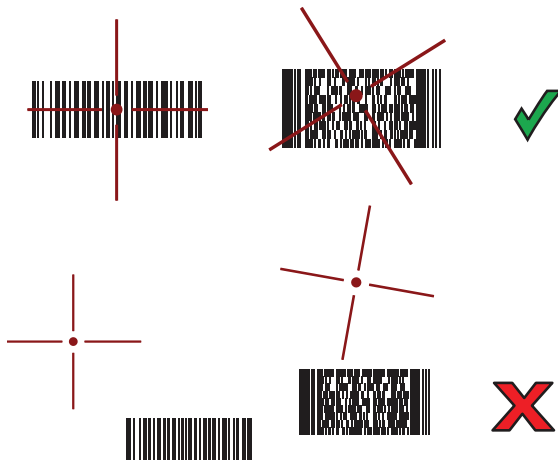

Figure 95 RS6000 Pick List Mode with Multiple Barcodes in Aiming Pattern



5. The captured data appears in the text field.

Scanning with RS507/RS507X Hands-Free Imager

To read a barcode, a scan-enabled app is required. The device contains the DataWedge app that allows you to enable the scanner to decode barcode data and display the barcode content.

To scan with the RS507/RS507X:

1. Pair the RS507/RS507X with the device. See [Pairing Using Simple Serial Interface](#), [Pairing Bluetooth Scanners](#) or [Pairing Using Bluetooth Human Interface Device](#) for more information.
2. Ensure that an app is open on the device and a text field is in focus (text cursor in text field).

- Point the RS507/RS507X at a barcode.

Figure 96 Barcode Scanning with RS507/RS507X

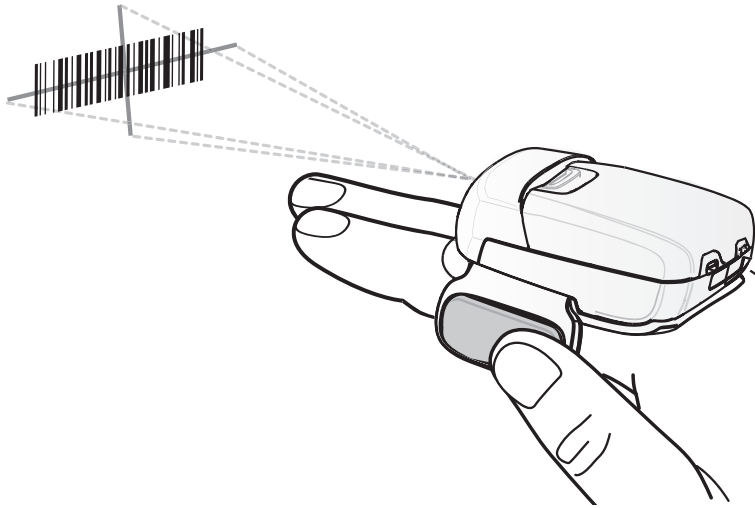

- Press and hold the trigger.

The red laser aiming pattern turns on to assist in aiming. Ensure the barcode is within the area formed by the cross-hairs in the aiming pattern. The aiming dot increases visibility in bright lighting conditions.

The RS507/RS507X LEDs light green and a beep sounds to indicate the barcode was decoded successfully. When the RS507/RS507X is in Pick List mode, the RS507/RS507X does not decode the barcode until the center of the crosshair touches the barcode.

Figure 97 RS507/RS507X Aiming Pattern

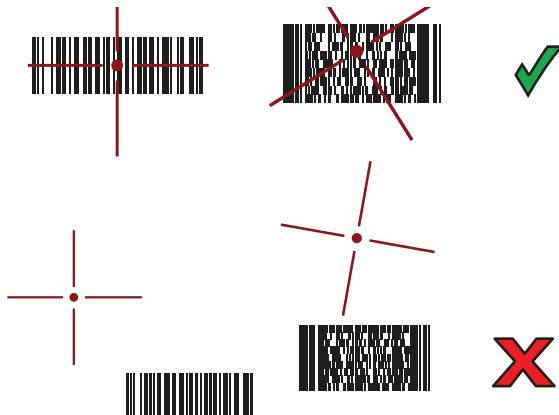

Figure 98 RS507/RS507X Pick List Mode with Multiple Barcodes in Aiming Pattern



- The captured data appears in the text field.

Pairing the RS507/RS507X/RS6000 Hands-Free Imager

To connect the RS507/RS507X or RS6000 imager to the device, use one of the following methods:

- Simple Serial Interface (SSI)
- Bluetooth Human Interface Device (HID) Mode.

Pairing Using Simple Serial Interface

To pair the RS507/RS507X or RS6000 with the device using SSI.

- Swipe up from the bottom of the Home screen and touch .

Figure 99 Bluetooth Pairing Utility



- Using the RS507/RS507X or RS6000, scan the barcode on the screen.

The RS507/RS507X or RS6000 emits a string of high/low/high/low beeps. The Scan LED flashes green indicating that the RS507/RS507X or RS6000 is attempting to establish connection with the device. When connection is established, the Scan LED turns off and the RS507/RS507X or RS6000 emits one string of low/high beeps.

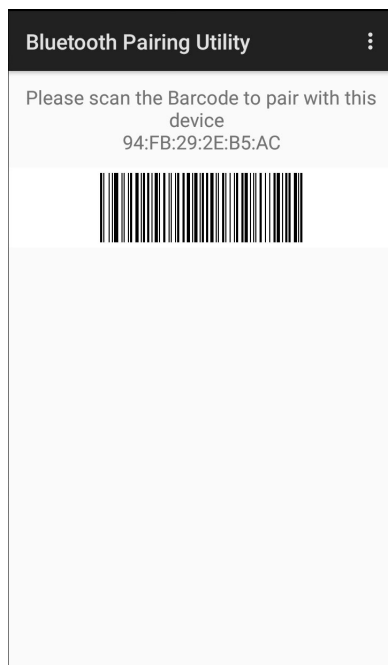
A notification appears on the Notification panel and the  icon appears in the Status bar.

Pairing Using Bluetooth Human Interface Device

To pair the RS507/RS507X or RS6000 with the device using Human Interface Device (HID):

- Ensure that Bluetooth is enabled on both devices.

2. Ensure that the Bluetooth device to discover is in discoverable mode.
3. Ensure that the two devices are within 10 meters (32.8 feet) of one another.
4. Place the RS507/RS507X or RS6000 in HID mode. If the RS507/RS507X or RS6000 is already in HID mode, skip to step 5.
 - a. Remove the battery from the RS507/RS507X or RS6000.
 - b. Press and hold the Restore key.
 - c. Install the battery onto the RS507/RS507X or RS6000.
 - d. Keep holding the Restore key for about five seconds until a chirp is heard and the Scan LEDs flash green.
 - e. Scan the barcode below to place the RS507/RS507X or RS6000 in HID mode.

Figure 100 RS507 Bluetooth HID Barcode



Figure 101 RS6000 Bluetooth HID Barcode

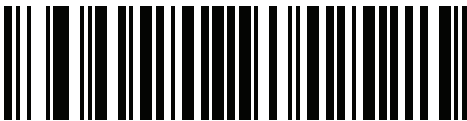

5. Remove the battery from the RS507/RS507X or RS6000.
6. Re-install the battery into the RS507/RS507X or RS6000.
7. Swipe down from the Status bar to open the Quick Access panel and then touch .
8. Touch **Bluetooth**.
9. Touch **Pair new device**. The device begins searching for discoverable Bluetooth devices in the area and displays them under **Available devices**.
10. Scroll through the list and select RS507/RS507X or RS6000.

The device connects to the RS507/RS507X or RS6000 and **Connected** appears below the device name. The Bluetooth device is added to the **Paired devices** list and a trusted (“paired”) connection is established.



A notification appears on Notification panel and the  icon appears in the Status bar.

DataWedge



DataWedge is a utility that adds advanced barcode scanning capability to any application without writing code. It runs in the background and handles the interface to built-in barcode scanners. The captured barcode data is converted to keystrokes and sent to the target application as if it was typed on the keypad.

To configure DataWedge refer to the device Integrator Guide or Product Reference Guide.

Enabling DataWedge

1. Swipe up from the bottom of the Home screen and touch .
2. Touch  > **Settings**.
3. Touch the **DataWedge enabled** checkbox. A blue checkmark appears in the checkbox indicating that DataWedge is enabled.
4. Touch .

Disabling DataWedge

1. Swipe up from the bottom of the Home screen and touch .
2. Touch  > **Settings**.
3. Touch the **DataWedge enabled** checkbox. A blue checkmark disappears from the checkbox indicating that DataWedge is disabled.
4. Touch .

Wireless

This section provides information on the wireless features:

- Wireless Wide Area Network (WWAN)
- Wireless Local Area Network (WLAN)
- Bluetooth.

Wireless Wide Area Networks



NOTE: Indonesian configurations do not support LTE.

Use Wireless wide area networks (WWANs) to access data over a cellular network. This section provides information on:

- Sharing a data connection
- Changing Cellular Network settings
- Locking a SIM card
- Monitoring data usage.

Sharing the Mobile Data Connection

The **Tethering & Portable Hotspot** settings allows sharing the mobile data connection with a single computer via USB tethering or Bluetooth tethering. Share the data connection with up to eight devices at once, by turning it into a portable Wi-Fi hotspot. While the device is sharing its data connection, an icon displays at the top of the screen and a corresponding message appears in the notification list.

Enabling USB Tethering



NOTE: USB tethering is not supported on computers running Mac OS. If the computer is running Windows or a recent version of Linux (such as Ubuntu), follow these instructions without any special preparation. If running a version of Windows that precedes Windows 7, or some other operating system, you may need to prepare the computer to establish a network connection via USB.

1. Connect the device to a host computer with the USB cable.
2. The notification **USB charging this device** appears in the Notifications panel.
3. Swipe down from the Status bar to open the Quick Access panel and then touch .
4. Touch **Network & Internet**.

5. Touch **Hotspot & tethering**.
6. Touch the **USB tethering** switch to enable.
The host computer is now sharing the device's data connection.

To stop sharing the data connection, touch the **USB tethering** switch again or disconnect the USB cable.

Enabling Bluetooth Tethering

Use Bluetooth tethering to share the data connection with a host computer.



Configure the host computer to obtain its network connection using Bluetooth. For more information, see the host computer's documentation.

1. Pair the device with the host computer.
2. Swipe down from the Status bar to open the Quick Access panel and then touch .
3. Touch **Networking & Internet**.
4. Touch **Hotspot & tethering**.
5. Touch the **Bluetooth tethering** switch to enable.
The host computer is now sharing the device's data connection.

To stop sharing the data connection, touch the **Bluetooth tethering** switch again.

Enabling Wi-Fi Hotspot

To enable the Wi-Fi Hotspot:

1. Swipe down from the Status bar to open the Quick Access panel and then touch .
2. Touch **Network & Internet**.
3. Touch **Hotspot & tethering**.
4. Touch the **Wi-Fi hotspot** switch to enable.
After a moment, the device starts broadcasting its Wi-Fi network name (SSID). Connect to it with up to eight computers or other devices. The Hotspot  icon appears in the Status bar.

To stop sharing the data connection, touch the **Portable Wi-Fi hotspot** switch again.

Configuring the Wi-Fi Hotspot

1. Swipe down from the Status bar to open the Quick Access panel and then touch .
2. Touch **Network & Internet**.
3. Touch **Hotspot & tethering**.
4. Touch **Set up Wi-Fi hotspot**.

Figure 102 Set up Wi-Fi Hotspot Dialog Box

5. In the **Network name** text field, edit the name for the hotspot.

6. Touch the **Security** option and select a security method from the drop-down list.
 - **None**
 - **WPA2 PSK.**



NOTE: If **None** is selected in the **Security** option, a password is not required.

7. In the **Password** text field, enter a password, if required.
8. In the **Select AP Band** drop-down list, select **2.4 GHz Band** or **5 GHz Band**.
9. Touch **Save**.

Cellular Network Settings

The following sections provide settings for cellular networks.

Disabling Data When Roaming

To prevent the device from transmitting data over other carriers' mobile networks when leaving an area that is covered by the carrier's networks. This is useful for controlling expenses if the service plan does not include data roaming.

GSM Devices

1. Swipe down from the Status bar to open the Quick Access panel and then touch .
2. Touch **Network & Internet > Mobile network**.
3. Slide the **Roaming** switch to the off position.

Enhanced 4G LTE Mode

Use LTE services to improve voice and other communication. This option is enabled by default.

Indonesian configurations do not support LTE.

Using Search for MicroCell

A MicroCell acts like a mini cell tower in a building or residence and connects to an existing broadband Internet service. It improves cell signal performance for voice calls, texts, and cellular data applications like picture messaging and Web surfing.





1. Swipe down from the Status bar to open the Quick Access panel and then touch .
2. Touch **Network & Internet > Mobile network**.
3. Touch **Search for AT&T MicroCell**.

Configuring the Access Point Name



NOTE: Many service provider Access Point Name (APN) data are pre-configured in the device. The APN information for all other service providers must be obtained from the wireless service provider.

To use the data on a network, configure the APN information:

1. Swipe down with two fingers from the status bar to open the quick access panel and then touch .
2. Touch **Network & Internet > Mobile network > Advanced**.
3. Touch **Access Point Names**.
4. Touch an APN name in the list to edit an existing APN or touch  to create a new APN.
5. Touch each APN setting and enter the appropriate data obtained from the wireless service provider.
6. When finished, touch  > **Save**.
7. Touch the radio button next to the APN name to start using it.
8. Touch .

Locking the SIM Card

Locking the SIM card requires the user to enter a PIN every time the device is turned on. If the correct PIN is not entered, only emergency calls can be made.

1. Swipe down from the Status bar to open the Quick Access panel and then touch .
2. Touch **Security & location**.
3. Touch **SIM card lock**.
4. Touch **Lock SIM card**.
5. Enter the PIN associated with the card. Touch **OK**.
6. Reset the device.

Data Usage

Data usage refers to the amount of data uploaded or downloaded by the device during a given period. Depending on the wireless plan, you may be charged additional fees when your data usage exceeds your plan's limit.

To monitor your data usage:

1. Swipe down from the Status bar to open the Quick Access panel and then touch .
2. Touch **Mobile network > Data usage > Data saver**.



CAUTION: The usage displayed on the data usage settings screen is measured by your device. Your carrier's data usage accounting may differ. Usage in excess of your carrier plan's data limits can result in steep overage charges. The feature described here can help you track your usage, but is not guaranteed to prevent additional charges.



Data usage settings allow:

- Set the data usage warning level.
- Set a data usage limit.
- View or restrict data usage by app.
- Identify mobile hotspots and restrict background downloads that may result in extra charges.

By default, the data usage settings screen displays the mobile data settings. That is, the data network or networks provided by your carrier.



Setting Data Usage Warning

To set a warning alert when the device has used a certain amount of mobile data:

1. Swipe down from the Status bar to open the Quick Access panel and then touch .
2. Touch **Data usage**.
3. Touch **Mobile data usage** >  > **Set data warning**.
4. Touch **Data warning**.
5. Enter a number. To switch between megabytes (MB) and gigabytes (GB), touch the down arrow.
6. Touch **SET**.

When the usage reaches the set level, a notification appears.

Setting Data Limit

1. Swipe down from the Status bar to open the Quick Access panel and then touch .
2. Touch **Data usage**.
3. Touch **Mobile data usage** >  > **Set data limit**.
4. Touch **OK**.
5. Touch **Data limit**.
6. Enter a number. To switch between megabytes (MB) and gigabytes (GB), touch the down arrow.
7. Touch **Set**.

When the limit is reached, data automatically turns off and a notification appears.

Wireless Local Area Networks

Wireless local area networks (WLANs) allow the device to communicate wirelessly inside a building. Before using the device on a WLAN, the facility must be set up with the required hardware to run the WLAN (sometimes known as infrastructure). The infrastructure and the device must both be properly configured to enable this communication.

Refer to the documentation provided with the infrastructure (access points (APs), access ports, switches, Radius servers, etc.) for instructions on how to set up the infrastructure.

Once the infrastructure is set up to enforce the chosen WLAN security scheme, use the **Wireless & networks** settings to configure the device to match the security scheme.

The device supports the following WLAN security options:

- Open
- Wireless Equivalent Privacy (WEP)
- Wi-Fi Protected Access (WPA)/WPA2 Personal (PSK)

- Extensible Authentication Protocol (EAP).
 - Protected Extensible Authentication Protocol (PEAP) - with MSCHAPV2 and GTC authentication
 - Transport Layer Security (TLS)
 - TTLS - with Password Authentication Protocol (PAP), MSCHAP and MSCHAPv2 authentication.

The **Status** bar displays icons that indicate Wi-Fi network availability and Wi-Fi status.



NOTE: To extend the life of the battery, turn off Wi-Fi when not in use.

Connecting to a Wi-Fi Network

To connect to a Wi-Fi network:

1. Swipe down from the Status bar to open the Quick Access panel.

Figure 103 Quick Access Panel

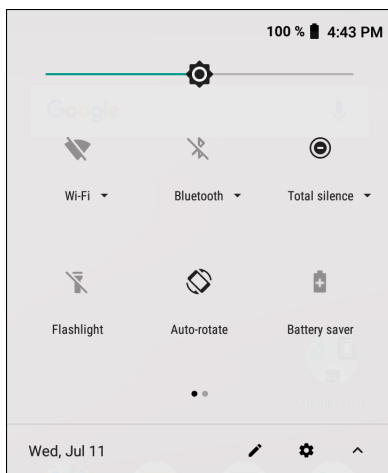

2. Touch **Wi-Fi** to open the **Wi-Fi** screen. The device searches for WLANs in the area and lists them.

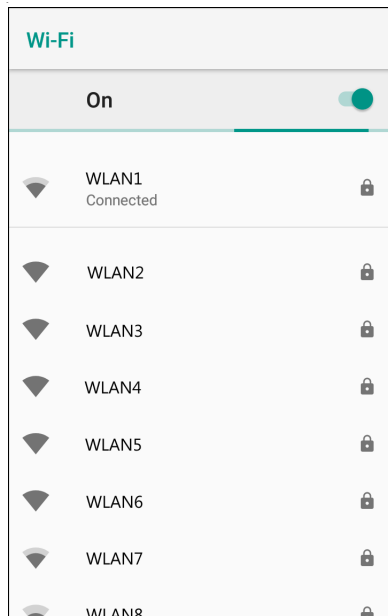

Figure 104 Wi-Fi Screen



3. Scroll through the list and select the desired WLAN network.
4. For open networks, touch profile once or press and hold and then select **Connect to network** or for secure networks enter the required password or other credentials then touch **Connect**. See the system administrator for more information.
The device obtains a network address and other required information from the network using the dynamic host configuration protocol (DHCP) protocol. To configure the device with a fixed internet protocol (IP) address, Refer to the device Integrator Guide for more information.
5. In the Wi-Fi setting field, **Connected** appears indicating that the device is connected to the WLAN.

Removing a Wi-Fi Network

To remove a remembered or connected network:

1. Swipe down from the status bar to open the quick access panel and then touch .
2. Touch **Network & Internet > W-Fi**.
3. Scroll down to the bottom of the list and touch **Saved networks**.
4. Touch the name of the network.
5. In the dialog box, touch **FORGET**.
6. Touch .

Bluetooth

Bluetooth devices can communicate without wires, using frequency-hopping spread spectrum (FHSS) radio frequency (RF) to transmit and receive data in the 2.4 GHz Industry Scientific and Medical (ISM) band

(802.15.1). Bluetooth wireless technology is specifically designed for short-range (10 m (32.8 ft)) communication and low power consumption.

Devices with Bluetooth capabilities can exchange information (for example, files, appointments, and tasks) with other Bluetooth enabled devices such as printers, access points, and other mobile devices.

The device supports Bluetooth Low Energy. Bluetooth Low Energy is targeted at applications in the healthcare, fitness, security, and home entertainment industries. It provides reduced power consumption and cost while maintaining standard Bluetooth range.

Adaptive Frequency Hopping

Adaptive Frequency Hopping (AFH) is a method of avoiding fixed frequency interferers, and can be used with Bluetooth voice. All devices in the piconet (Bluetooth network) must be AFH-capable in order for AFH to work. There is no AFH when connecting and discovering devices. Avoid making Bluetooth connections and discoveries during critical 802.11b communications. AFH for Bluetooth consists of four main sections:

- Channel Classification - A method of detecting an interference on a channel-by-channel basis, or pre-defined channel mask.
- Link Management - Coordinates and distributes the AFH information to the rest of the Bluetooth network.
- Hop Sequence Modification - Avoids interference by selectively reducing the number of hopping channels.
- Channel Maintenance - A method for periodically re-evaluating the channels.

When AFH is enabled, the Bluetooth radio “hops around” (instead of through) the 802.11b high-rate channels. AFH coexistence allows enterprise devices to operate in any infrastructure.

The Bluetooth radio in this device operates as a Class 2 device power class. The maximum output power is 2.5 mW and the expected range is 10 m (32.8 ft). A definition of ranges based on power class is difficult to obtain due to power and device differences, and whether in open space or closed office space.



NOTE: It is not recommended to perform Bluetooth wireless technology inquiry when high rate 802.11b operation is required.

Security

The current Bluetooth specification defines security at the link level. Application-level security is not specified. This allows application developers to define security mechanisms tailored to their specific need. Link-level security occurs between devices, not users, while application-level security can be implemented on a per-user basis. The Bluetooth specification defines security algorithms and procedures required to authenticate devices, and if needed, encrypt the data flowing on the link between the devices. Device authentication is a mandatory feature of Bluetooth while link encryption is optional.

Pairing of Bluetooth devices is accomplished by creating an initialization key used to authenticate the devices and create a link key for them. Entering a common personal identification number (PIN) in the devices being paired generates the initialization key. The PIN is never sent over the air. By default, the Bluetooth stack responds with no key when a key is requested (it is up to user to respond to the key request event). Authentication of Bluetooth devices is based-upon a challenge-response transaction. Bluetooth allows for a PIN or passkey used to create other 128-bit keys used for security and encryption. The encryption key is derived from the link key used to authenticate the pairing devices. Also worthy of note is the limited range and fast frequency hopping of the Bluetooth radios that makes long-distance eavesdropping difficult.

Recommendations are:

- Perform pairing in a secure environment

- Keep PIN codes private and do not store the PIN codes in the device
- Implement application-level security.

Bluetooth Profiles

The device supports the Bluetooth services listed in the table below:

Table 12 *Bluetooth Profiles*

Profile	Description
Service Discovery Protocol (SDP)	Handles the search for known and specific services as well as general services.
Serial Port Profile (SPP)	Allows use of RFCOMM protocol to emulate serial cable connection between two Bluetooth peer devices. For example, connecting the device to a printer.
Object Push Profile (OPP)	Allows the device to push and pull objects to and from a push server.
Advanced Audio Distribution Profile (A2DP)	Allows the device to stream stereo-quality audio to a wireless headset or wireless stereo speakers.
Audio/Video Remote Control Profile (AVRCP)	Allows the device to control A/V equipment to which a user has access. It may be used in concert with A2DP.
Personal Area Network (PAN)	Allows the use of Bluetooth Network Encapsulation Protocol to provide L3 networking capabilities over a Bluetooth link. Only PANU role is supported.
Human Interface Device Profile (HID)	Allows Bluetooth keyboards, pointing devices, gaming devices and remote monitoring devices to connect to the device.
Headset Profile (HSP)	Allows a hands-free device, such as a Bluetooth headset, to place and receive calls on the device.
Hands-Free Profile (HFP)	Allows car hands-free kits to communicate with the device in the car.
Phone Book Access Profile (PBAP)	Allows exchange of Phone Book Objects between a car kit and a mobile device to allow the car kit to display the name of the incoming caller; allow the car kit to download the phone book so you can initiate a call from the car display.
Symbol Serial Interface (SSI)	Allows for communication with Bluetooth Imager.
File Transfer Profile (FTP)	Provides the capability to browse, manipulate and transfer files in file system of another system. Uses GOEP as a basis.
Generic Attribute Profile (GATT)	Provides profile discovery and description services for Bluetooth Low Energy protocol. It defines how attributes are grouped together into sets to form services.
HID Over GATT Profile (HOGP)	Defines the procedures and features used by Bluetooth low energy HID Devices using GATT and Bluetooth HID Hosts using GATT.

Table 12 *Bluetooth Profiles (Continued)*

Profile	Description
Scan Parameters Profile (ScPP)	Provides devices with information to assist them in managing their connection idle timeout and advertising parameters to optimize for power consumption and/or reconnection latency.
SIM Access Profile (SAP)	Allows devices such as car phones with built-in GSM transceivers to connect to a SIM card in a Bluetooth enabled device.
Message Access Profile (MAP)	Defines the features and procedures used by devices that exchange message objects.

Bluetooth Power States

The Bluetooth radio is off by default:

- Suspend - When the device goes into suspend mode, the Bluetooth radio stays on.
- Airplane Mode - When the device is placed in Airplane Mode, the Bluetooth radio turns off. When Airplane mode is disabled, the Bluetooth radio returns to the prior state. When in Airplane Mode, the Bluetooth radio can be turned back on if desired.

Bluetooth Radio Power

Turn off the Bluetooth radio to save power or if entering an area with radio restrictions (for example, an airplane). When the radio is off, other Bluetooth devices cannot see or connect to the device. Turn on the Bluetooth radio to exchange information with other Bluetooth devices (within range). Communicate only with Bluetooth radios in close proximity.



NOTE: To achieve the best battery life, turn off radios when not in use.

Enabling Bluetooth

To enable Bluetooth:

1. Swipe down from the Status bar to open the Quick Access panel.
2. Touch  to turn Bluetooth on.
3. Touch .

Disabling Bluetooth

To disable Bluetooth:

1. Swipe down from the Status bar to open the Quick Access panel.
2. Touch  to turn Bluetooth off.
3. Touch .



Discovering Bluetooth Device(s)

The device can receive information from discovered devices without pairing. However, once paired, the device and a paired device exchange information automatically when the Bluetooth radio is on. To find Bluetooth devices in the area:

1. Ensure that Bluetooth is enabled on both devices.
2. Ensure that the Bluetooth device to discover is in discoverable mode.
3. Ensure that the two devices are within 10 meters (32.8 feet) of one another.
4. Swipe down from the Status bar to open the Quick Access panel.
5. Touch **Bluetooth**.
6. Touch **MORE SETTINGS**. The **Bluetooth** screen appears.
7. Touch **Pair new device**. The device begins searching for discoverable Bluetooth devices in the area and displays them under **Available devices**.
8. Scroll through the list and select a device. The Bluetooth pairing request dialog box appears.
9. Touch **Pair** on both devices.
10. The Bluetooth device is added to the **Paired devices** list and a trusted (“paired”) connection is established.

Changing the Bluetooth Name

By default, the device has a generic Bluetooth name that is visible to other devices when connected.

1. Swipe down from the Status bar to open the Quick Access panel and then touch .
2. Touch **Connected devices > Bluetooth**.
3. If Bluetooth is not on, move the switch to turn Bluetooth on.
4. Touch **Device name**.
5. Enter a name and touch **RENAME**.
6. Touch .



Connecting to a Bluetooth Device

Once paired, connect to a Bluetooth device.

1. Swipe down from the Status bar to open the Quick Access panel and then touch .
2. Touch **Connected device > Bluetooth**.
3. In the list, touch the unconnected Bluetooth device.
When connected, **Connected** appears below the device name.



Selecting Profiles on the Bluetooth Device

Some Bluetooth devices have multiple profiles. To select a profile:

1. Swipe down from the Status bar to open the Quick Access panel and then touch .
2. Touch **Connected Devices > Bluetooth**.
3. In the **Paired Devices** list, touch  next to the device name.
4. Turn on or off a profile to allow the device to use that profile.
5. Touch .

Unpairing a Bluetooth Device

To unpair a Bluetooth device and erase all pairing information:

1. Swipe down from the Status bar to open the Quick Access panel and then touch .
2. Touch **Connected devices > Bluetooth**.
3. In the **Paired Devices** list, touch  next to the device name.
4. Touch **FORGET**.
5. Touch .

Accessories

This chapter provides information for using the accessories for the device.

Accessories

This table lists the accessories available for the device.

Table 13 *Accessories*

Accessory	Part Number	Description
Cradles		
1-Slot Base Charge Only Cradle	CRD-TC2X-BS1CO-01	Provides charging for device and Extended power pack. Requires power supply (PWR-WUA5V12W0xx), and USB-C cable.
1-Slot Ethernet Cradle	CRD-TC2X-SE1ET-01	Provides device charging and communication, and charging for Extended Power Pack. Requires power supply (PWR-BGA12V50W0WW), DC line cord (CBL-DC-388A1-01), and country-specific AC line cord.
5-Slot Charge Only Cradle	CRD-TC2X-SE5CO-01	Charges up to five devices. Requires power supply (PWR-BGA12V108W0WW), DC line cord (CBL-DC-382A1-01), and country-specific AC line cord.
Cradle Mount	BRKT-SCRD-SMRK-01	Mounts the 5-Slot Charge Only Cradle to a wall or rack.
Batteries and Chargers		
Extended Power Pack	BTRY-TC2X-PRPK1-01	Charges the device internal battery to provide additional power and extend the shift time.
Vehicle Solutions		
Cigarette Light Adapter Auto Charge Cable	CHG-AUTO-USB1-01	Provides power to the device from a cigarette lighter socket.
Vehicle Cradle	CRD-TC2X-VCH1-01	Provides mounting solution for the device in a vehicle.

Table 13 *Accessories (Continued)*

Accessory	Part Number	Description
Audio Accessories		
3.5 mm Audio Adapter	CBL-TC51-HDST35-01	Plugs into the device and provides audio to a wired headset with collared 3.5 mm plug.
3.5 mm Headset	HDST-35MM-PTVP-01	Use for PTT calls.
Miscellaneous		
Trigger Handle	TRG-TC2X-SNP1-01	Adds gun-style handle with a scanner trigger for comfortable and productive scanning.
Screen Protector	KT-TC20-SCRNP1-01	Add additional screen protection.
SmartDEX Solution	DEX30	Provides wireless DEX communications to the device.
Ethernet Bracket	BRKT-TC51-ENET1-01	Use to connect the USB/Ethernet Adapter to the 1-Slot Ethernet Cradle.
USB/Ethernet Module	MOD-MT2-EU1-01	Use with 1-Slot Ethernet Cradle to provide Ethernet connectivity.
Cradle Mating Adapter	KIT-TC2X-BS1FT-05	Use the optional mating adapter to connect two or more cradles together. Each cradle still requires a power supply (5-pack).
Carrying Solutions		
TC2X Soft Holster	SG-TC2X-HLSTR1-01	Use to hold the device on hip. Accepts TC20 device with Trigger Handle.
TC20K Soft Holster	SG-TC20K-HLST1-01	Use to hold the device on hip. Accepts TC20K device with Trigger Handle.
TC2X Hand Strap	SG-TC2X-HSTRP1-01	Replacement hand strap (3-pack).
TC20K Hand Strap	SG-TC20K-HSTP1-01	Replacement hand strap for TC20K (3-pack).
Wrist/Arm Mount	SG-TC2X-ARMNT-01	Use to mount the device to the forearm.
Small Wrist Mount	SG-WT4023221-03R	Replacement small wrist mount strap.
Large Wrist Mount	SG-WT4023221-04R	Replacement long wrist mount strap.
Power Supplies		
Power Supply	PWR-BGA12V50W0WW	Provides power to the 1-Slot Ethernet Cradle. Requires DC Line Cord, p/n CBL-DC-388A1-01 and country specific three wire grounded AC line cord sold separately.
Power Supply	PWR-BGA12V108W0WW	Provides power to the 5-Slot Charge Only cradle. Requires DC Line Cord, p/n CBL-DC-382A1-01 and country specific three wire grounded AC line cord sold separately.
Power Supply	PWR-WUA5V12W0US	Provides 5 VDC, 2.5 A power to the USB-C cable. Includes plug adapter for use in the United States.
Power Supply	PWR-WUA5V12W0GB	Provides 5 VDC, 2.5 A power to the USB-C cable. Includes plug adapter for use in the European Union.

Table 13 *Accessories (Continued)*

Accessory	Part Number	Description
Power Supply	PWR-WUA5V12W0EU	Provides 5 VDC, 2.5 A power to the USB-C cable. Includes plug adapter for use in the United Kingdom.
Power Supply	PWR-WUA5V12W0AU	Provides 5 VDC, 2.5 A power to the USB-C cable. Includes plug adapter for use in Australia.
Power Supply	PWR-WUA5V12W0CN	Provides 5 VDC, 2.5 A power to the USB-C cable. Includes plug adapter for use in China.
Power Supply	PWR-WUA5V12W0BR	Provides 5 VDC, 2.5 A power to the USB-C cable. Includes plug adapter for use in Brazil.
Power Supply	PWR-WUA5V12W0KR	Provides 5 VDC, 2.5 A power to the USB-C cable. Includes plug adapter for use in Korea.
Power Supply	PWR-WUA5V12W0IN	Provides 5 VDC, 2.5 A power to the USB-C cable. Includes plug adapter for use in India.
DC Line Cord	CBL-DC-382A1-01	Provides power from the power supply (PWR-BGA12V108W0WWW) to the 5-Slot Charge Only Cradle.
DC Line Cord	CBL-DC-388A1-01	Provides power from the power supply (PWR-BGA12V50W0WWW) to the 1-Slot Ethernet Cradle.
2-Way DC Line Cord	CBL-DC-377A1-01	Use to charge two 5-Slot Charge only Cradles with one power supply.
2-Way DC Line Cord	CBL-DC-379A1-01	Use to charge one 1-Slot Ethernet Cradle and one 5-Slot Charge Only Cradle with one power supply.
4-Way DC Line Cord	CBL-DC-380A1-01	Use to charge four 1-Slot Ethernet Cradles with one power supply.
US AC Line Cord	23844-00-00R	7.5 feet long, grounded, three wire for power supply.
USB-C Cable	CBL-TC2X-USBC-01	The USB cable used to connect PC to single slot USB cradle.

1-Slot Base Charge Only Cradle

The 1-Slot Base Charge Only Cradle provide 5 VDC for charging:

- TC20 battery
- Extended Power Pack
- TC20 and Extended Power Pack
- TC20 with Trigger Handle.



IMPORTANT: Use only the Zebra USB-C Cable for charging.

Figure 105 1-Slot Base Charge Only Cradle

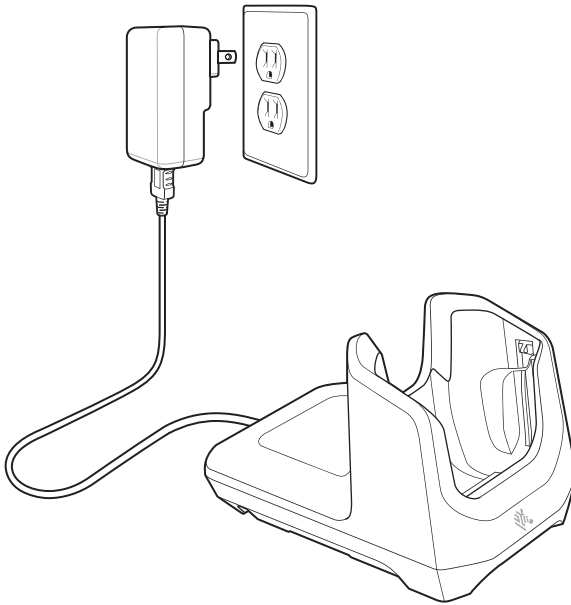

Charging the Device

To charge a device:

1. Insert the device into the slot to begin charging.

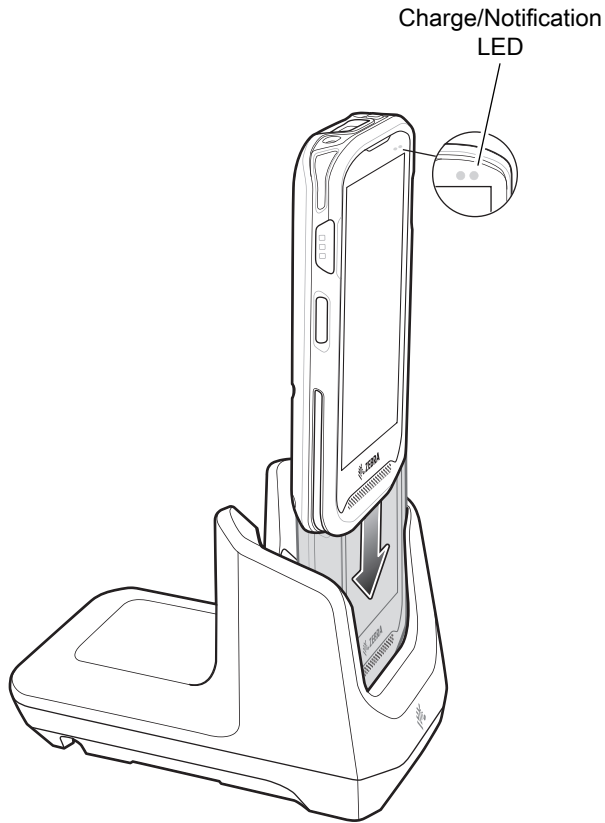
Figure 106 TC20 Charging

2. Ensure the device is seated properly.

Battery Charging

The device's Charging/Notification LED indicates the status of the battery charging in the device. See [Table 4 on page 22](#) for device charging status. The internal battery charges from fully depleted to 90% in approximately four hours and from fully depleted to 100% in approximately five hours.



NOTE: In many cases the 90% charge provides plenty of charge for daily use. A full 100% charge lasts for approximately 10 hours of use.

To achieve the best fast charging results use only Zebra charging accessories and batteries. Charge batteries at room temperature with the device in sleep mode.

Charging Temperature

Charge batteries in temperatures from 0°C to 40°C (32°F to 104°F). The device or cradle always performs battery charging in a safe and intelligent manner. At higher temperatures (e.g. approximately +37°C (+98°F)) the device or cradle may for small periods of time alternately enable and disable battery charging to keep the battery at acceptable temperatures. The device and cradle indicates when charging is disabled due to abnormal temperatures via its LED.

1-Slot Ethernet Cradle

The 1-Slot Ethernet Cradle:

- Provides 5 VDC for charging:
 - TC20 battery
 - Extended Power Pack
 - TC20 and Extended Power Pack
 - TC20 with Trigger Handle.
- Provides USB communication.
- Provides Ethernet and USB communication using the USB/Ethernet Adapter.



IMPORTANT: When the device with attached Extended Power Pack is in the cradle, USB or Ethernet communication is disabled.

Figure 107 1-Slot Ethernet Cradle

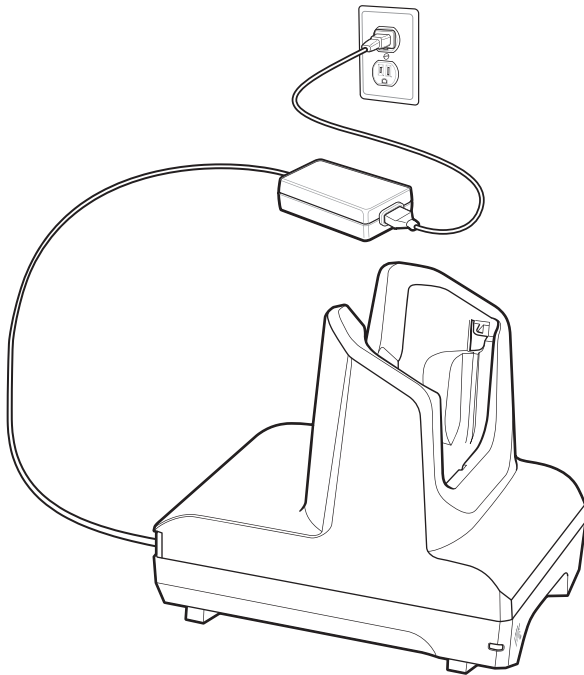

USB/Ethernet Communication

The 1-Slot Ethernet Cradle with an Ethernet Bracket and USB/Ethernet Module provides both Ethernet communication with a network and USB communication with a host computer. Prior to using the cradle for Ethernet or USB communication, ensure that the switch on the USB/Ethernet module is set properly. See the TC20 Mobile Computer Integrator Guide for Android 8.1.0 Oreo for information on setting up the Ethernet Bracket and USB/Ethernet Module.

Figure 108 1-Slot Ethernet Cradle Module Switch

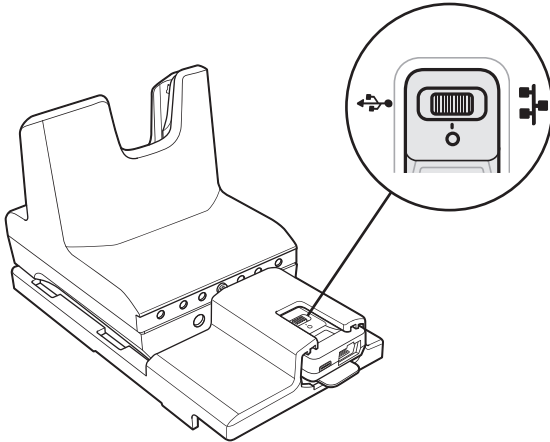

For Ethernet communication, slide the switch to the  position.

For USB communication, slide the switch to the  position.

Place the switch in the center position  to disable communications.

Ethernet LED Indicators

There are two LEDs on the USB/Ethernet Module RJ-45 connector. The green LED lights to indicate that the transfer rate is 100 Mbps. When the LED is not lit the transfer rate is 10 Mbps. The yellow LED blinks to indicate activity, or stays lit to indicate that a link is established. When it is not lit it indicates that there is no link.

Figure 109 LED Indicators

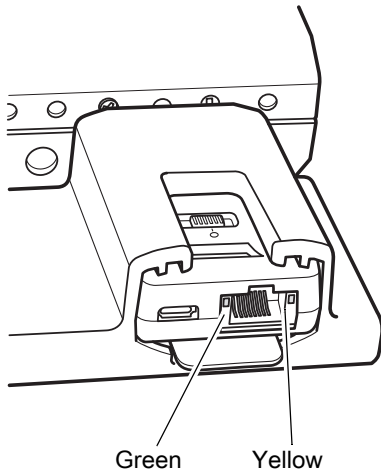



Table 14 USB/Ethernet Module LED Data Rate Indicators

Data Rate	Yellow LED	Green LED
100 Mbps	On/Blink	On
10 Mbps	On/Blink	Off

Establishing Ethernet Connection



NOTE: Refer to the TC20 Mobile Computer Integrator Guide for Android 8.0 Oreo for information on configuring the Ethernet settings.

1. Swipe down with two fingers from the status bar to open the quick access panel and then touch .
2. Touch **Ethernet**.
3. Slide the Ethernet switch to the **ON** position.
4. Insert the device into a slot.
The  icon appears in the Status bar.
5. Touch **Eth0** to view Ethernet connection details.

Charging the Device

To charge a device:

1. Insert the device into the slot to begin charging.

Figure 110 Battery Charging

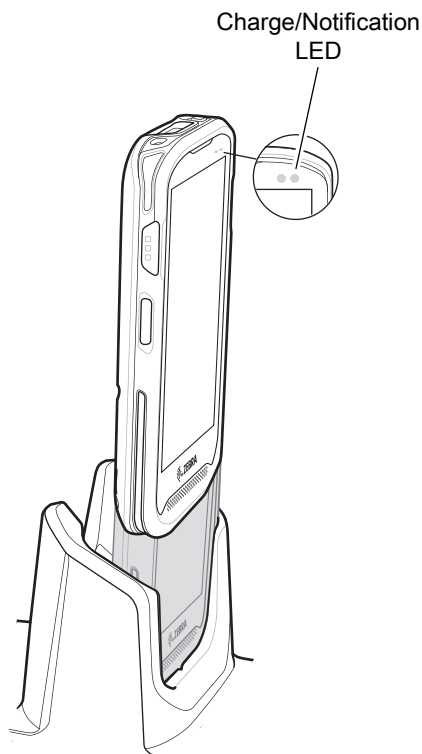

2. Ensure the device is seated properly.

Battery Charging

The device's Charging/Notification LED indicates the status of the battery charging in the device. See [Table 4 on page 22](#) for device charging status. The internal battery charges from fully depleted to 90% in approximately four hours and from fully depleted to 100% in approximately five hours.



NOTE: In many cases the 90% charge provides plenty of charge for daily use. A full 100% charge lasts for approximately 10 hours of use.

To achieve the best fast charging results use only Zebra charging accessories and batteries. Charge batteries at room temperature with the device in sleep mode.

Charging Temperature

Charge batteries in temperatures from 0°C to 40°C (32°F to 104°F). The device or cradle always performs battery charging in a safe and intelligent manner. At higher temperatures (e.g. approximately +37°C (+98°F)) the device or cradle may for small periods of time alternately enable and disable battery charging to keep the battery at acceptable temperatures. The device and cradle indicates when charging is disabled due to abnormal temperatures via its LED.

5-Slot Charge Only Cradle

The 5-Slot Charge Only Cradle provides 5 VDC for charging:

- TC20 battery
- Power Pack
- TC20 and Power Pack
- TC20 with Trigger Handle.

Figure 111 5-Slot Charge Only Cradle

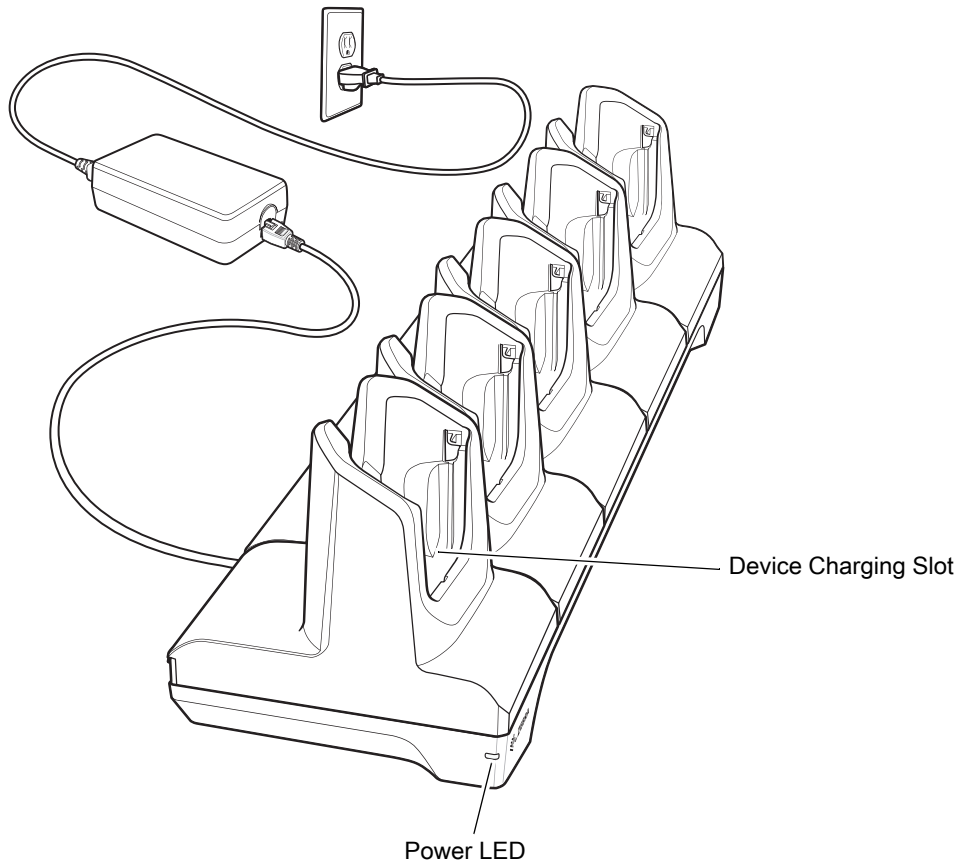

Charging the TC20

To charge a device:

1. Insert the device into a slot to begin charging.

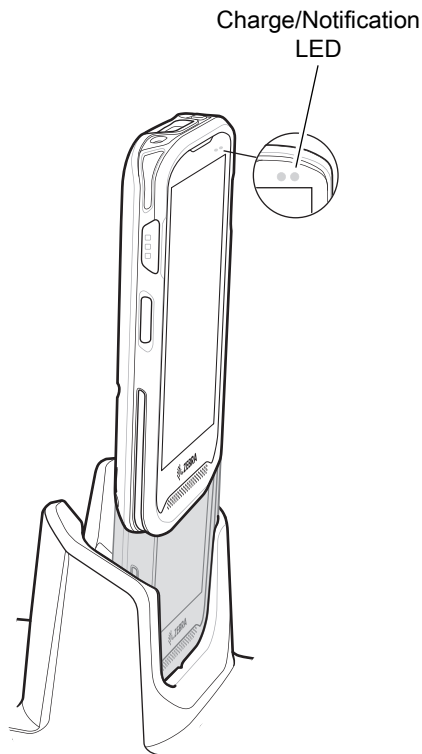
Figure 112 TC20 Charging

2. Ensure the device is seated properly.

Battery Charging

The device's Charging/Notification LED indicates the status of the battery charging in the device. See [Table 4 on page 22](#) for device charging status. The internal battery charges from fully depleted to 90% in approximately four hours and from fully depleted to 100% in approximately five hours.



NOTE: In many cases the 90% charge provides plenty of charge for daily use. A full 100% charge lasts for approximately 10 hours of use.

To achieve the best fast charging results use only Zebra charging accessories and batteries. Charge batteries at room temperature with the device in sleep mode.

Charging Temperature

Charge batteries in temperatures from 0°C to 40°C (32°F to 104°F). The device or cradle always performs battery charging in a safe and intelligent manner. At higher temperatures (e.g. approximately +37°C (+98°F)) the device or cradle may for small periods of time alternately enable and disable battery charging to keep the battery at acceptable temperatures. The device and cradle indicates when charging is disabled due to abnormal temperatures via its LED.

Extended Power Pack

The Extended Power Pack provides additional power for charging the device battery.

For best performance it is recommended that the Power Pack should always be installed on the device and that both the Power Pack and device are fully charged at the start of each work shift.

Figure 113 Extended Power Pack Front View

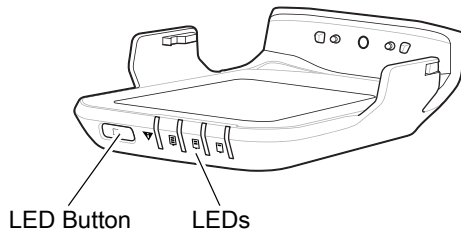
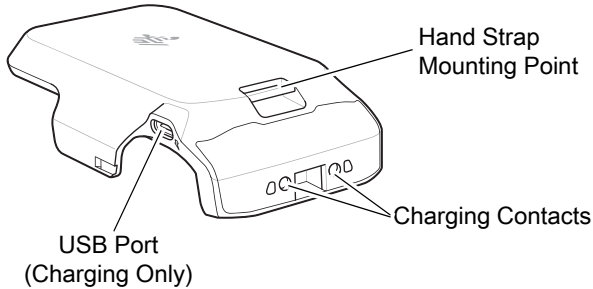

Figure 114 Extended Power Pack Back View



Installation

To install the Power Pack:

1. Align the Power Pack with the device.

Figure 115 Align Power Pack with TC20

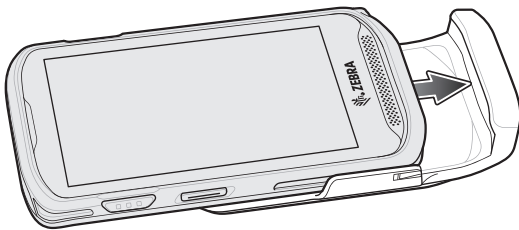

2. Slide the power pack up onto the device until it snaps into place.

Charging

Charge the Extended Power Pack:

- In a cradle
- In a cradle attached to the device
- using a USB cable.

Figure 116 Charging Power Pack in Cradle

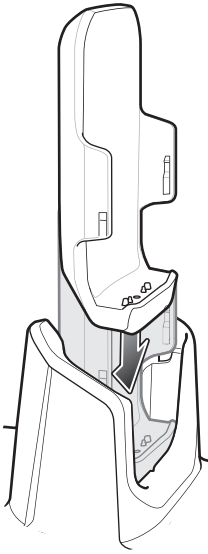
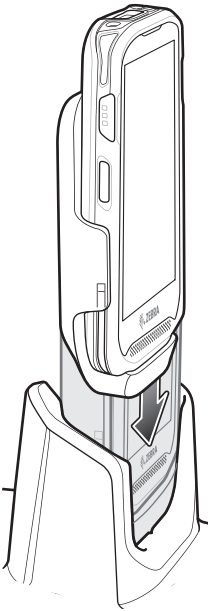
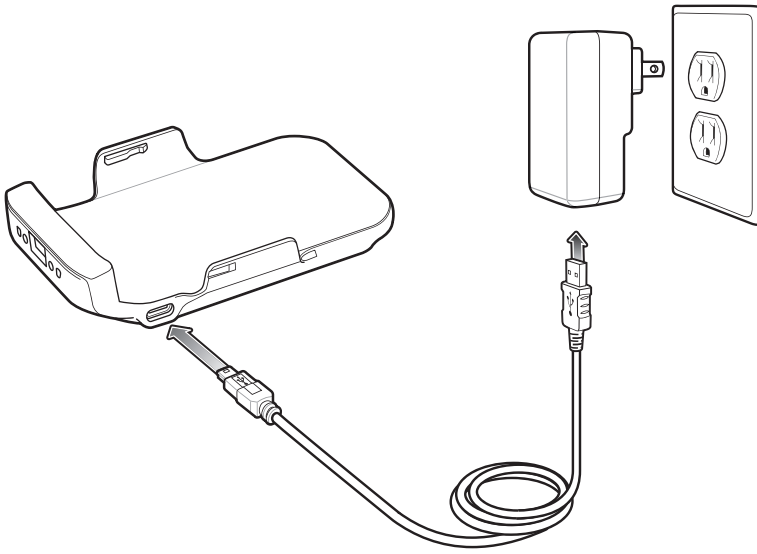

Figure 117 Charging TC20 and Power Pack in Cradle



IMPORTANT: Use only the Zebra USB-C Cable for charging.

Figure 118 Charging with USB Cable



Power Pack Charging

The Power Pack Charging LEDs indicate the status of charging. See Table 15 on page 145 for charging status. The power pack charges from fully depleted to 90% in approximately four hours and from fully depleted to 100% in approximately five hours.

Figure 119 Power Pack LEDs

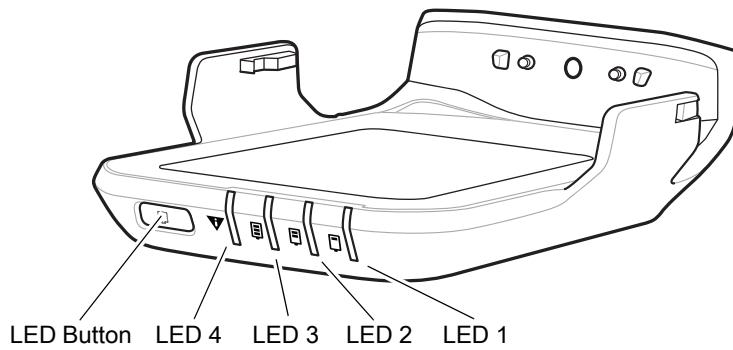













Table 15 LED Charging Indicators

LED State				Indication
LED 1	LED 2	LED 3	LED 4	
□	□	□	□	Not charging.
█ Flashing	□	□	□	Charge level is between 0% and 33%.
█ Solid	█ Flashing	□	□	Charge level is between 33% and 66%.

Table 15 LED Charging Indicators (Continued)

LED State				Indication
LED 1	LED 2	LED 3	LED 4	
 Solid	 Solid	 Flashing		Charge level is between 66% and 95%.
 Solid	 Solid	 Solid		Fully charged (95-100%).
 	 	 	 Flashing	Charging error, e.g.: <ul style="list-style-type: none"> • Temperature is too low or too high. • Charging has gone on too long without completion (typically 10 hours).

Charging Temperature

Charge batteries in temperatures from 0°C to 40°C (32°F to 104°F). The device or cradle always performs battery charging in a safe and intelligent manner. At higher temperatures (e.g. approximately +37°C (+98°F)) the device or cradle may for small periods of time alternately enable and disable battery charging to keep the battery at acceptable temperatures. The power pack indicates when charging is disabled due to abnormal temperatures via its LED.

Check Power Level

To check the power level of the power pack, press the LED button. The LEDs light indicating the charge level. After five seconds the LEDs turn off.

Figure 120 Check Power Level

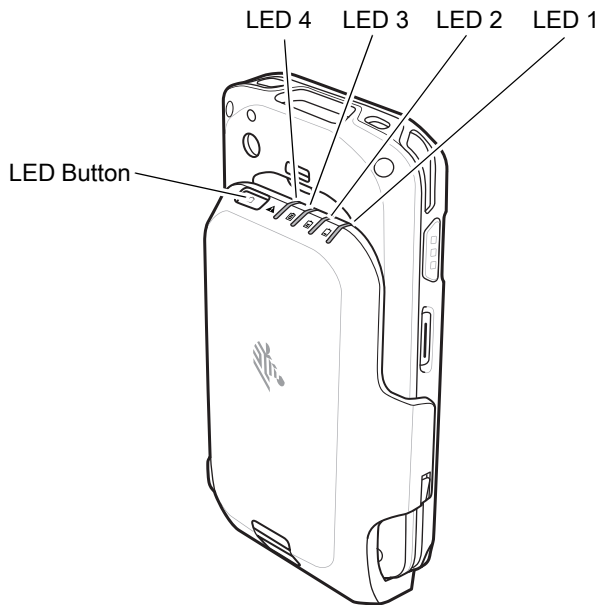





















Table 16 LED Charge State Indicators

LED State				Indication
LED 1	LED 2	LED 3	LED 4	
				No charge.
 Flashing				Charge level is between 0% and 33%.
 Solid	 Flashing			Charge level is between 33% and 66%.
 Solid	 Solid	 Flashing		Charge level is between 66% and 95%.
 Solid	 Solid	 Solid		Fully charged (95-100%).

Resetting the Extended Power Pack

If the user thinks that the pack is not operating properly, reset the pack:

Press and hold the button for 10 seconds. All four LEDs flash three times.

Trigger Handle



IMPORTANT: Trigger Handle can only be used on devices with SE4710 imager, and 2-Pin or 8-Pin Access Door.

The Trigger Handle adds a gun-style handle with a scanning trigger to the device. It increases comfort when using the device in scan-intensive applications for extended periods of time.

Figure 121 Trigger Handle

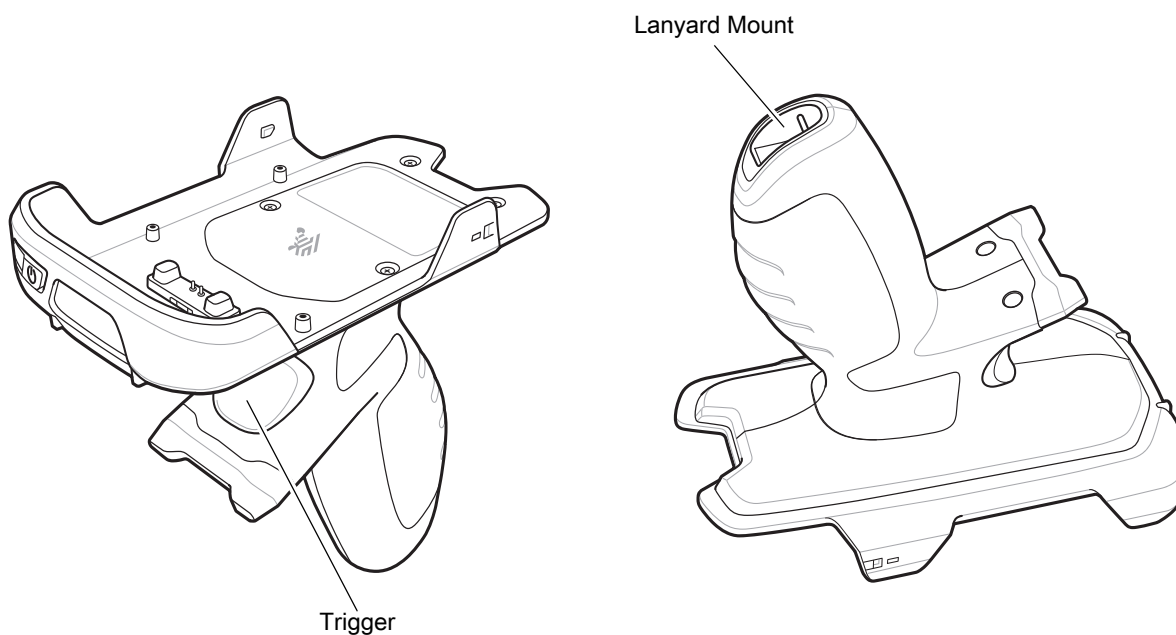

Installing the Optional Lanyard

To install the lanyard onto the Trigger Handle:

1. Insert the loop end of the tether into the slot on the bottom of the handle.
2. Feed the lanyard through the loop.

Figure 122 Install Attachment Plate to Handle

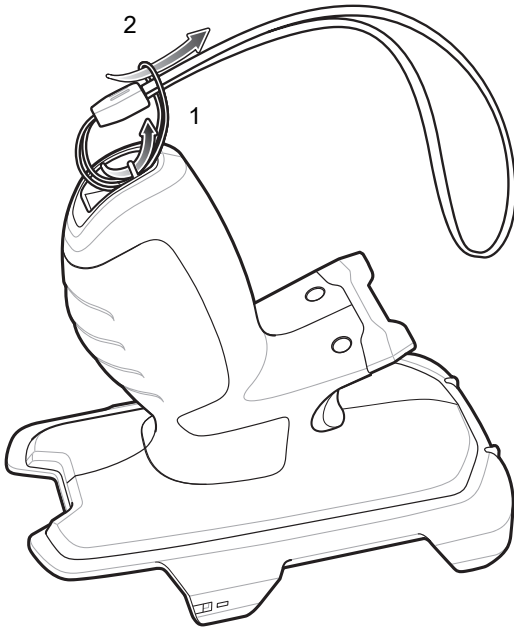

3. Pull the lanyard until the loop tightens.

Inserting the Device into the Trigger Handle

To install the device onto the Trigger handle:

1. Align and insert the top of the device into the front of the Trigger Handle.

Figure 123 Insert Device into Trigger Handle

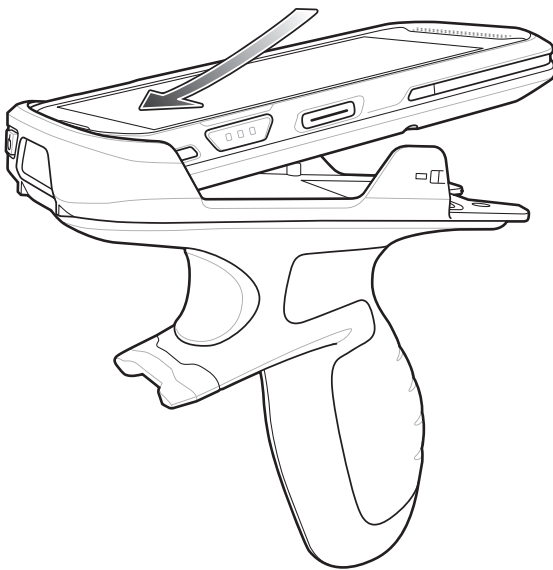

2. Rotate the device down and press down until it snaps into place.

Figure 124 Rotate Device onto Trigger Handle

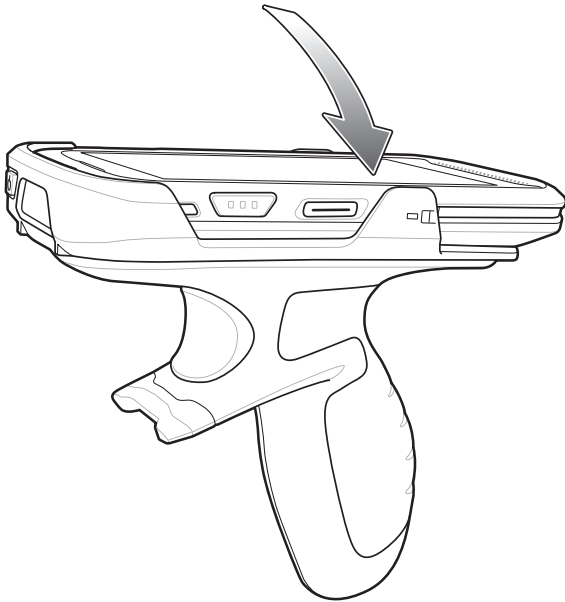

Removing the Device from the Trigger Handle

To remove the device from the Trigger Handle:

1. Using thumb, push the device up.

Figure 125 Push Device Up

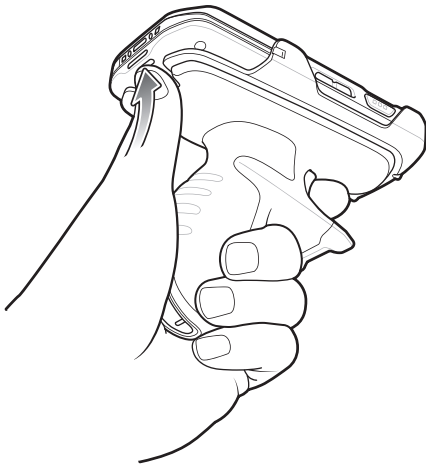

2. Slide the device away from the front of the Trigger Handle.

Figure 126 Remove Device from Trigger Handle

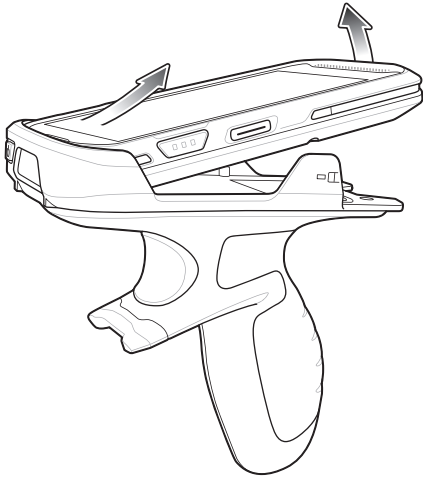

Wrist/Arm Mount

The Wrist/Arm Mount allows the user to mount the device onto the forearm for hands-free applications. Install the mount on either arm with the short strap installed closest to the wrist. The user might have to remove and re-install the straps for proper installation. See Strap Installation on page 156 for instructions for installing straps.

Figure 127 Wrist/Arm Mount

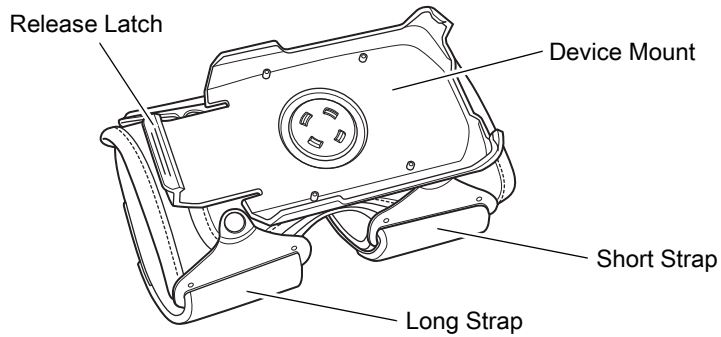

Wrist/Arm Mount Installation

To install the Wrist/Arm Mount:

1. Loosen both straps.
2. Slide the Wrist/Arm Mount onto arm with the short strap closest to the wrist.

Figure 128 Slide onto Forearm

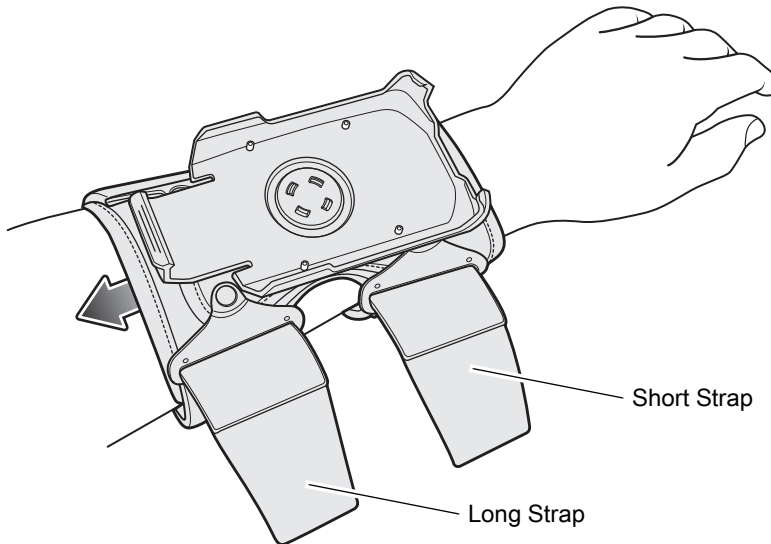

3. Tighten both straps on forearm and press hook and loop material together.

Figure 129 Tighten Straps

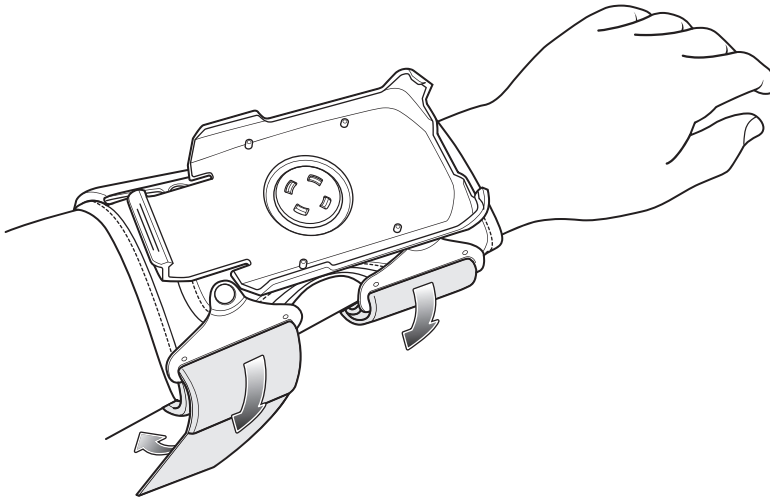

Device Installation

To install the device onto the mount:

1. Insert the top of the device into the end of the mount.

Figure 130 Insert TC20 in Holder

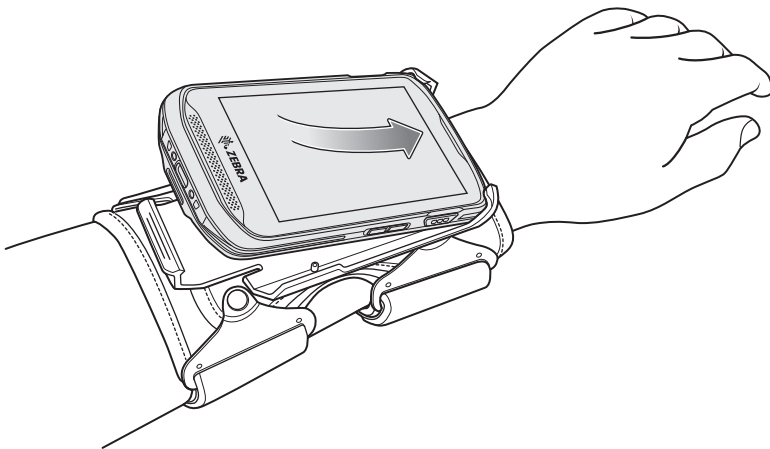

2. Rotate the bottom of the device into the mount and snap into place.

Figure 131 Secure Device

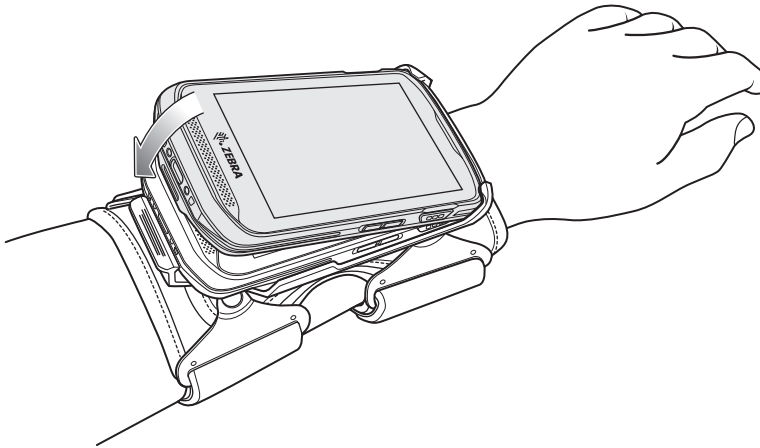

3. Rotate the device for best viewing.

Figure 132 Device Rotation

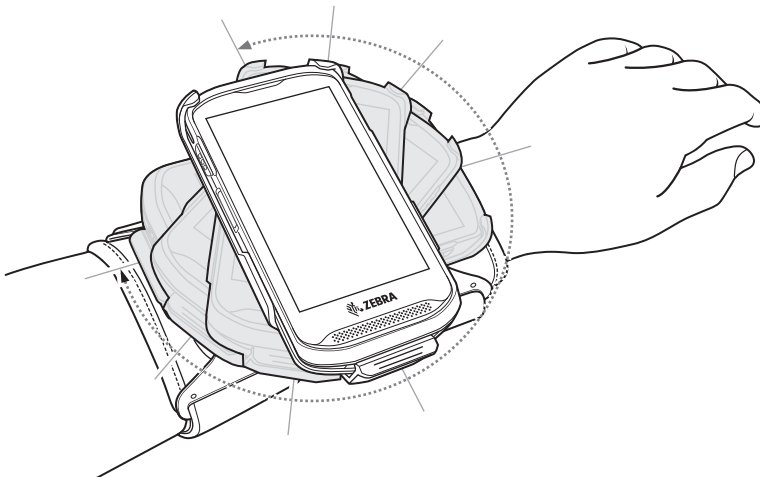

Device Removal

To remove the device from the Wrist/Arm Mount:

1. Press down on the release lever.
2. Slide the device out of the mount.

Figure 133 TC20 Removal

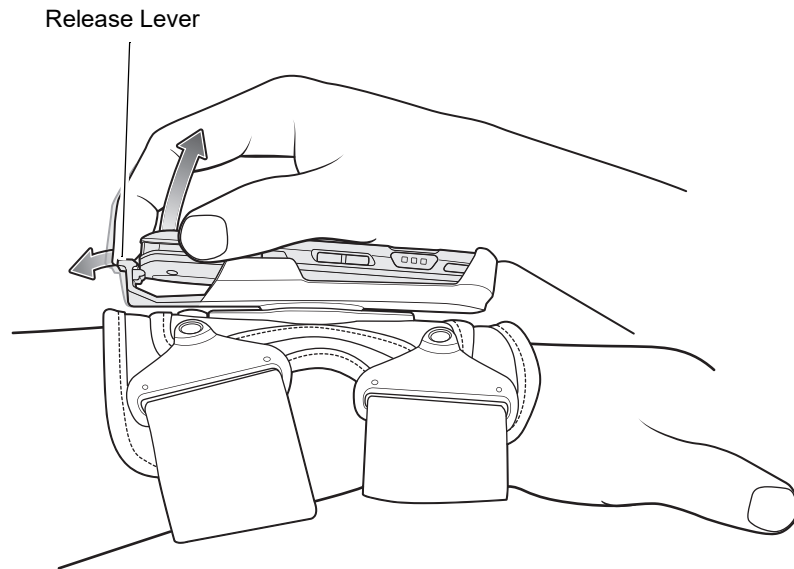

Scanning

To scan with device in the wrist mount, rotate the device as shown below.

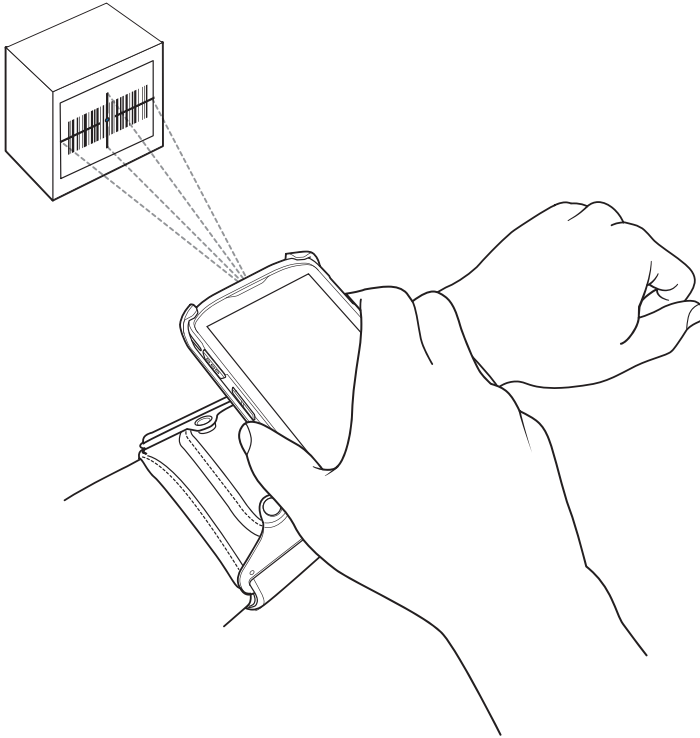
Figure 134 Scanning with Wrist Mount

Strap Installation

The user can remove strap for replacement or clean and then re-install new straps.

1. Remove existing straps.
2. Feed the soft end of the strap through the slot on the rear holder with hook material positioned as shown below.

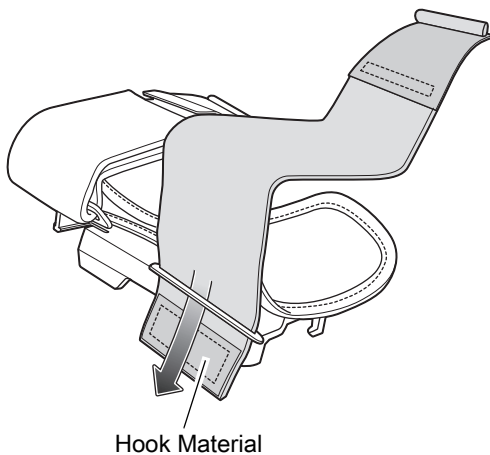
Figure 135 Feed Strap through Rear Slots

3. Fold end over and press hook and loop material together.

Figure 136 Fold End and Secure

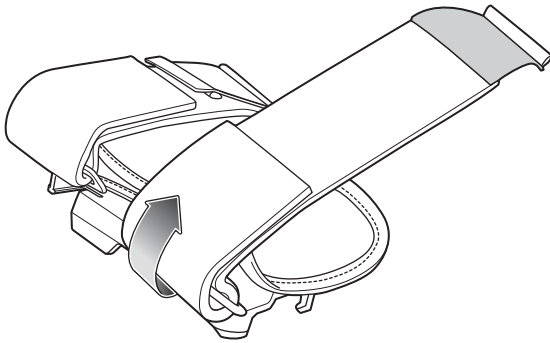

4. Feed the hard end through the slot in the front holder.

Figure 137 Feed End Through Front Slot

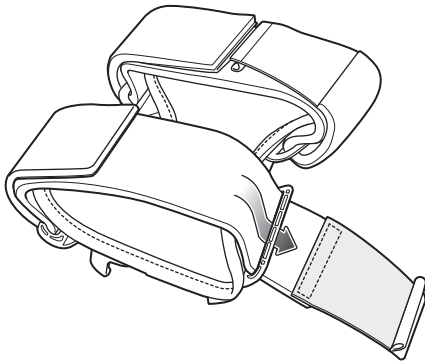

5. Fold over and press the hook and loop material together.

Figure 138 Fold End and Secure

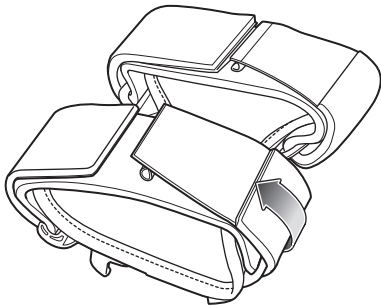

Hand Strap



NOTE: There are two different hand straps for the device and the TC20K. The TC20K hand strap is longer. TC20 hand strap installation is shown below. TC20K hand strap installation is the same.

The hand strap provides securing when holding the device.

To install the hand strap on the device:

1. Feed the top end of the hand strap through the slot at the top of the device.

Figure 139 Insert Hand Strap Through Top Mounting Point

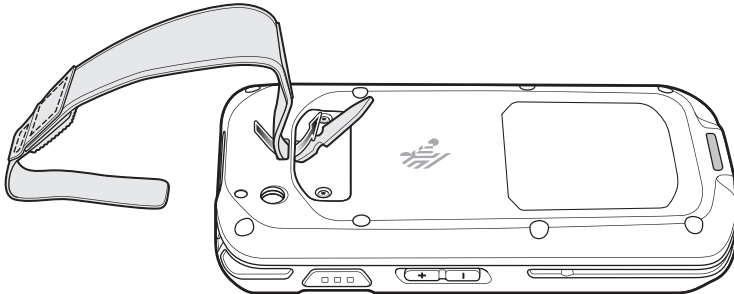

2. Pull the end through the slot.

Figure 140 Feed End Through Slot

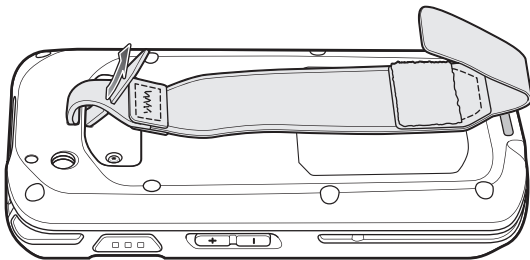

3. Insert the end of the hand strap into the slot on the hand strap.
4. Pull the end until the notch sits into the slot.
5. Feed the other end of the hand strap through the slot at the bottom of the device.

Figure 141 Insert Hand Strap Through Bottom Mounting Point

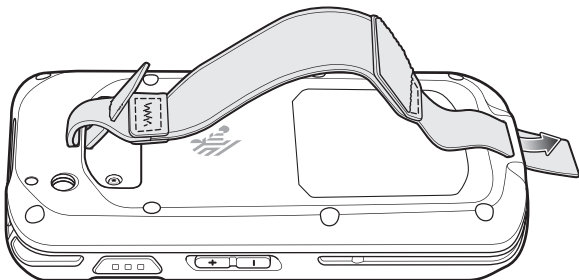

6. Pull the end through the slot.
7. Press the hook material against the loop material.

Figure 142 Adjust and Close Hand Strap End

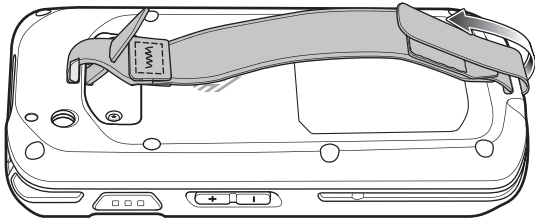

8. Place hand between device and hand strap and adjust hand strap as necessary.

To install the hand strap on the device with an Extended Power Pack:

1. Feed the top end of the hand strap through the slot at the top of the device.

Figure 143 Insert Hand Strap Through Top Mounting Point

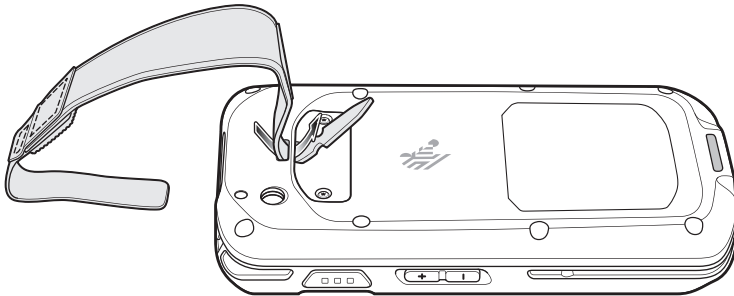

2. Pull the end through the slot.

3. Insert the end of the hand strap into the slot on the hand strap.

4. Pull the end until the notch sits into the slot.

Figure 144 Feed End Through Slot

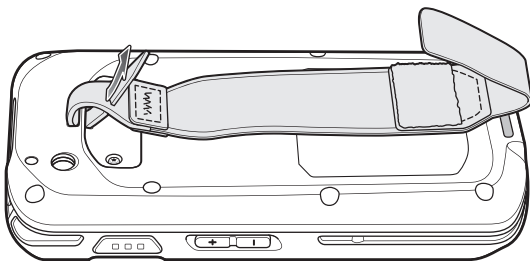

5. Feed the other end of the hand strap through the slot at the bottom of the device.

6. Slide the device into the Extended Power Pack.

Figure 145 Insert Hand Strap Through Power Pack Bottom Mounting Point

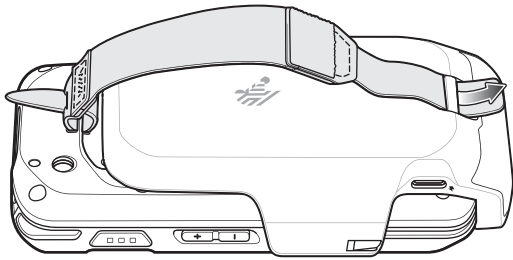

7. Pull the end through the slot.
8. Press the hook material against the loop material.

Figure 146 Adjust and Close

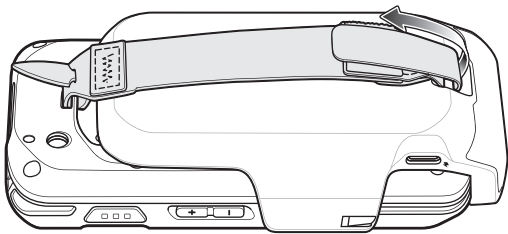

9. Place hand between device and hand strap and adjust hand strap as necessary.

Soft Holster



NOTE: There are two different soft holsters for the TC20 and the TC20K. The TC20K soft holster is longer. TC20 soft holster installation is shown below. TC20K soft holster installation is the same.

Use the soft holster to securely hold the device on a belt for easy access. The holster has an adjustable belt for securing the device or Trigger Handle.

Figure 147 Soft Holster

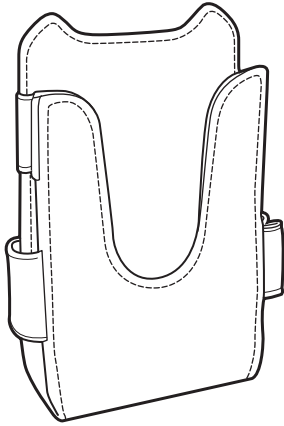

Adjusting the Holster

The holster has an adjustable belts that securely hold the device or Trigger Handle.

Figure 148 Adjust Belts

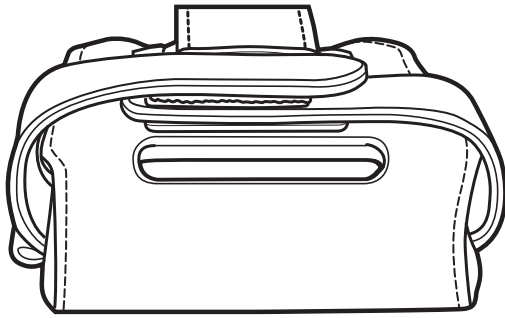

Pull Belts Tight for Device

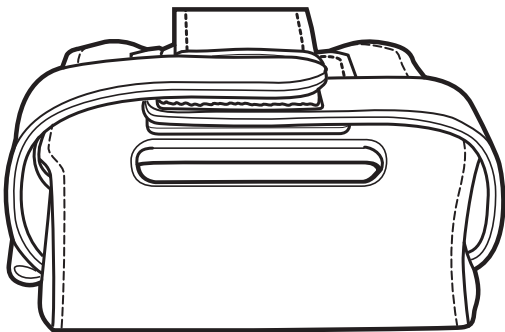

Leave Belts Loose for Trigger Handle and
Extended Power Pack

Insert the device into the holster with the device exit window facing up and the display against the body.

Figure 149 Device in Holster

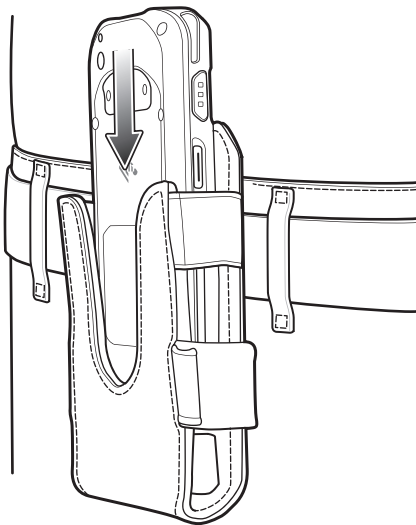

Insert the device and Extended Power Pack into the holster with the device exit window facing up and the display against the body.

Figure 150 Device with Extended power Pack in Holster

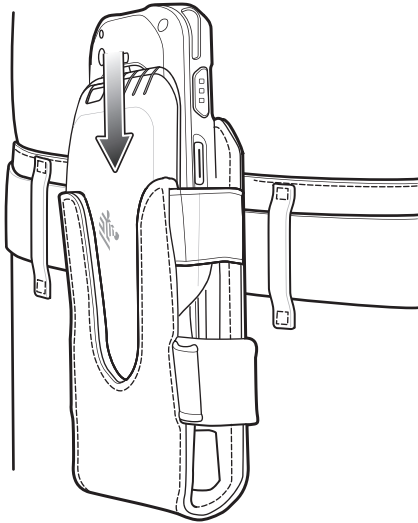

Insert the Trigger Handle into the holster with the device exit window facing down.

Figure 151 Trigger Handle in Holster

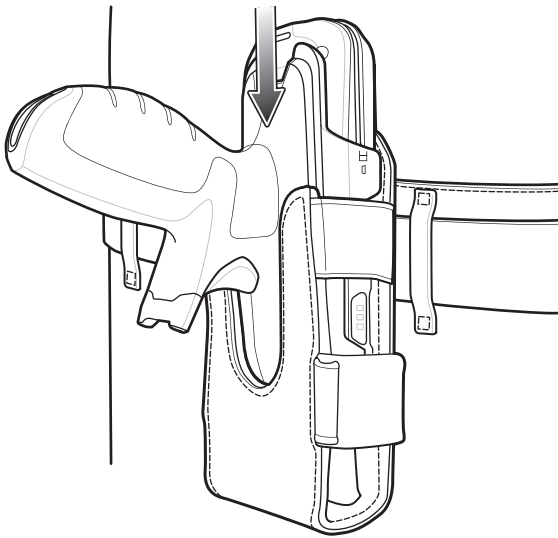

Maintenance and Troubleshooting

This chapter includes instructions on cleaning and storing the device, and provides troubleshooting solutions for potential problems during operation.

Maintaining the TC25

For trouble-free service, observe the following tips when using the TC25:

- Do not scratch the screen of the TC25.
- The touch-sensitive screen of the TC25 is glass. Do not drop the TC25 or subject it to strong impact.
- Protect the TC25 from temperature extremes. Do not leave it on the dashboard of a car on a hot day, and keep it away from heat sources.
- Do not store or use the TC25 in any location that is dusty, damp, or wet.
- Use a soft lens cloth to clean the TC25. If the surface of the TC25 screen becomes soiled, clean it with a soft cloth moistened with a diluted window-cleaning solution.

Display Best Practices

Image Retention

Image retention may occur when a static image continuously displays for extended periods of time. A user may see a faint remnant of the image even after a new image displays. To prevent image retention:

- set the display to turn off after a few minutes of idle time.
- rotate background images on a periodic basis.
- turn off the display when the device is not in use.
- use a screen saver with the following characteristics:
 - background color set to black
 - use a small moving image (approximately 2% of the display size).
 - move the image randomly across the screen
 - screen saver should be active as long as the static image is used.

Long-Term Storage

When storing the device for long periods of time, ensure that the battery has at least 50% charge and is stored at (temperature).

Cleaning Instructions



CAUTION: Always wear eye protection.

Read warning label on compressed air and alcohol product before using.

If you have to use any other solution for medical reasons please contact the Global Customer Support Center for more information.



WARNING: Avoid exposing this product to contact with hot oil or other flammable liquids. If such exposure occurs, unplug the device and clean the product immediately in accordance with these guidelines.

Approved Cleanser Active Ingredients

100% of the active ingredients in any cleaner must consist of one or some combination of the following: isopropyl alcohol, or mild dish soap.

Harmful Ingredients

The following chemicals are known to damage the plastics on the device and should not come in contact with the device: ammonia solutions, compounds of amines or ammonia; acetone; ketones; ethers; aromatic and chlorinated hydrocarbons; aqueous or alcoholic alkaline solutions; ethanolamine; toluene; trichloroethylene; benzene; carboic acid and TB-lysoform.

Cleaning Instructions

Do not apply liquid directly to the device. Dampen a soft cloth or use pre-moistened wipes. Do not wrap the device in the cloth or wipe, but gently wipe the unit. Be careful not to let liquid pool around the display window or other places. Allow the unit to air dry before use.

Special Cleaning Notes

Many vinyl gloves contain phthalate additives, which are often not recommended for medical use and are known to be harmful to the housing of the device. The device should not be handled while wearing vinyl gloves containing phthalates, or before hands are washed to remove contaminant residue after gloves are removed. If products containing any of the harmful ingredients listed above are used prior to handling the device, such as hand sanitizer that contain ethanolamine, hands must be completely dry before handling the device to prevent damage to the plastics.

Cleaning Materials Required

- Alcohol wipes
- Lens tissue
- Cotton-tipped applicators
- Isopropyl alcohol
- Can of compressed air with a tube.

Cleaning Frequency

The cleaning frequency is up to the customer's discretion due to the varied environments in which the mobile devices are used. They may be cleaned as frequently as required, but it is advisable to clean the camera window periodically when used in dirty environments to ensure optimum performance.

Cleaning the TC25

Housing

Using the alcohol wipes, wipe the housing including buttons.

Display

The display can be wiped down with the alcohol wipes, but care should be taken not to allow any pooling of liquid around the edges of the display. Immediately dry the display with a soft, non-abrasive cloth to prevent streaking.

Camera and Exit Window

Wipe the camera and exit window periodically with a lens tissue or other material suitable for cleaning optical material such as eyeglasses.

Connector Cleaning

To clean the connectors:

1. Power off the device
2. Dip the cotton portion of the cotton-tipped applicator in isopropyl alcohol.
3. Rub the cotton portion of the cotton-tipped applicator back-and-forth across the connector. Do not leave any cotton residue on the connector.
4. Repeat at least three times.
5. Use the cotton-tipped applicator dipped in alcohol to remove any grease and dirt near the connector area.
6. Use a dry cotton-tipped applicator and repeat steps 4 through 6.



CAUTION: Do not point nozzle at yourself and others, ensure the nozzle or tube is away from your face.

7. Spray compressed air on the connector area by pointing the tube/nozzle about ½ inch away from the surface.
8. Inspect the area for any grease or dirt, repeat if required.

Cleaning Cradle Connectors

To clean the connectors on a cradle:

1. Remove the DC power cable from the cradle.
2. Dip the cotton portion of the cotton-tipped applicator in isopropyl alcohol.
3. Rub the cotton portion of the cotton-tipped applicator along the pins of the connector. Slowly move the applicator back-and-forth from one side of the connector to the other. Do not leave any cotton residue on the connector.
4. All sides of the connector should also be rubbed with the cotton-tipped applicator.



CAUTION: Do not point nozzle at yourself and others, ensure the nozzle or tube is pointed away from your face.

5. Spray compressed air in the connector area by pointing the tube/nozzle about ½ inch away from the surface.
6. Remove any lint left by the cotton-tipped applicator.
7. If grease and other dirt can be found on other areas of the cradle, use a lint-free cloth and alcohol to remove.
8. Allow at least 10 to 30 minutes (depending on ambient temperature and humidity) for the alcohol to air dry before applying power to cradle.

If the temperature is low and humidity is high, longer drying time is required. Warm temperature and dry humidity requires less drying time.

Troubleshooting

The following tables provides typical problems that might arise and the solution for correcting the problem.

TC25

Table 17 *Troubleshooting the TC25*

Problem	Cause	Solution
When pressing the power button the TC25 does not turn on.	Battery not charged.	Charge the battery in the TC25.
	System crash.	Perform a reset.
When pressing the power button the TC25 does not turn on but two LEDs blink.	Battery charge is at a level where data is maintained but battery should be re-charged.	Charge the battery in the TC25.
Battery did not charge.	Battery failed.	Contact system administrator.
	TC25 removed from cradle while battery was charging.	Insert TC25 in cradle. See Charging the Battery on page 20 .
	Extreme battery temperature.	Battery does not charge if ambient temperature is below 0°C (32°F) or above 40°C (104°F).
Cannot see characters on display.	TC25 not powered on.	Press the Power button.

Table 17 *Troubleshooting the TC25 (Continued)*

Problem	Cause	Solution
During data communication with a host computer, no data transmitted, or transmitted data was incomplete.	TC25 removed from cradle or disconnected from host computer during communication.	Replace the TC25 in the cradle, or reattach the communication cable and re-transmit.
	Incorrect cable configuration.	See the system administrator.
	Communication software was incorrectly installed or configured.	Perform setup.
During data communication over Wi-Fi, no data transmitted, or transmitted data was incomplete.	Wi-Fi radio is not on.	Turn on the Wi-Fi radio.
	You moved out of range of an access point.	Move closer to an access point.
During data communication over Bluetooth, no data transmitted, or transmitted data was incomplete.	Bluetooth radio is not on.	Turn on the Bluetooth radio.
	You moved out of range of another Bluetooth device.	Move within 10 meters (32.8 feet) of the other device.
No sound.	Volume setting is low or turned off.	Adjust the volume.
TC25 shuts off.	TC25 is inactive.	The display turns off after a period of inactivity. Set this period to 15 seconds, 30 seconds, 1, 2, 5, 10 or 30 minutes.
	Battery is depleted.	Charge the battery.
Tapping the window buttons or icons does not activate the corresponding feature.	The device is not responding.	Reset the device.
A message appears stating that the TC25 memory is full.	Too many files stored on the TC25.	Delete unused memos and records. If necessary, save these records on the host computer (or use an SD card for additional memory).
	Too many applications installed on the TC25.	Remove user-installed applications on the TC25 to recover memory. Select  > Apps . Select the unused program and tap Uninstall .

Table 17 *Troubleshooting the TC25 (Continued)*

Problem	Cause	Solution
The TC25 does not decode with reading barcode.	Scanning application is not loaded.	Load a scanning application on the TC25 or enable DataWedge. See the system administrator.
	Unreadable barcode.	Ensure the symbol is not defaced.
	Distance between exit window and barcode is incorrect.	Place the TC25 within proper scanning range.
	TC25 is not programmed for the barcode.	Program the TC25 to accept the type of barcode being scanned. Refer to the EMDK or DataWedge application.
	TC25 is not programmed to generate a beep.	If the TC25 does not beep on a good decode, set the application to generate a beep on good decode.
	Battery is low.	If the scanner stops emitting a laser beam upon a trigger press, check the battery level. When the battery is low, the scanner shuts off before the TC25 low battery condition notification. Note: If the scanner is still not reading symbols, contact the distributor or the Global Customer Support Center.
TC25 cannot find any Bluetooth devices nearby.	Too far from other Bluetooth devices.	Move closer to the other Bluetooth device(s), within a range of 10 meters (32.8 feet).
	The Bluetooth device(s) nearby are not turned on.	Turn on the Bluetooth device(s) to find.
	The Bluetooth device(s) are not in discoverable mode.	Set the Bluetooth device(s) to discoverable mode. If needed, refer to the device's user documentation for help.
Cannot unlock TC25.	User enters incorrect password.	If the user enters an incorrect password eight times, the user is requested to enter a code before trying again. If the user forgot the password, contact system administrator.

Technical Specifications

The following sections provide technical specification for the device.

TC25

Table 18 *TC25 Technical Specifications*

Item	Description
Physical Characteristics	
Dimensions	Length: 134.0 mm (5.3 in.) Width: 71.3 mm (2.8 in.) Depth: 17.9 mm (0.7 in.)
Weight	200 g (7.1 oz)
Display	4.3 in. High Definition (800 x 480) WVGA
Touch Panel	Capacitive Touch Panel; multi-touch
Backlight	Light Emitting Diode (LED) backlight
Internal Battery	Rechargeable 3,000 mAh (typical) / 2,900 mAh (minimum) Li-Ion.
Expansion Slot	User accessible microSD up to 32 GB (SDHC) or up to 128 GB (SDXC) formatted in exFAT.
Connection Interface	One USB OTG (host/client) type C connector
Notification	Audible tone; multi-color LEDs, vibration
Voice and Audio	PTT Pro and PTT Express support. Voice support (internal speaker/microphone). Two microphones; speaker; and audio jack.
Performance Characteristics	
CPU	QCOM MSM8937 64-bit, 8-core, ARM Cortex A53 1.4 GHz, 512 kB L2 cache, power-optimization
Operating System	Android 8.1.0 Oreo
Memory	2 GB RAM/16 GB or 32 GB Flash
Output Power	USB - 5 VDC @ 500 mA max

Technical Specifications

Table 18 *TC25 Technical Specifications (Continued)*

Item	Description
User Environment	
Operating Temperature	-10°C to 50°C (14°F to 122°F)
Storage Temperature	-40°C to 70°C (-40°F to 158°F)
Charging Temperature	0° C to 40° C (32°F to 104°F)
Relative Humidity	Operating: 5 to 95% non-condensing
Drop Specification	Multiple 1.2 m (4 ft.) to tile over concrete per MIL-STD at room temperature.
Tumble	300 0.5 m (1.6 ft.) tumbles
Sealing	IP54
Electrostatic Discharge (ESD)	± 20 kVDC air discharge, ± 10 kVDC direct discharge, ± 10 kVDC indirect discharge
Vibration	4 g's peak, 5 Hz to 2 kHz, 1 hour duration per axis
Thermal Shock	-40°C to 70°C (-40°F to 158°F) rapid transition. 10 cycles: (1 cycle = 1.25 hours at -40°C and 1.25 hours at 70°C.
Interactive Sensor Technology (IST)	
Motion Sensor	3-axis accelerometer
Light Sensor	Ambient light sensor to auto adjust display backlight brightness
Proximity Sensor	Automatically detects when the user places the handset against head during a phone call to disable display output and touch input.
Wireless LAN Data and Voice Communications	
Radio	IEEE 802.11 a/b/g/n/ac/d/r/k/w/v/h/i IPv4, IPv6
Data Rates Supported	2.4GHz: 802.11b/g/n - up to 150 Mbps 5GHz: 802.11a/n/ac - up to 433.3 Mbps
Operating Channels	2.4 GHz: Chan 1 - 13; 1 - 11 (US) 5GHz: Chan 36-48, 52-64, 100-140, 149-151, 161-165 Channel Bandwidth: 20, 40, 80 MHz Actual operating channels/frequencies and bandwidth depend on regulatory rules and certification agency.
Security and Encryption	WEP (40 or 104 bit); WPA/WPA2 Personal (TKIP and AES); WPA/WPA2 Enterprise (TKIP and AES) — EAP-TTLS (PAP, MSCHAP, MSCHAPv2), EAP-TLS, PEAPv0-MSCHAPv2.
Certifications	802.11 a/b/g/n/ac; WPA; WPA2
Fast Roam	802.11

Technical Specifications

Table 18 *TC25 Technical Specifications (Continued)*

Item	Description
Wireless WAN Data and Voice Communications	
Frequency band	Worldwide: LTE: 700/800/900/1800/2100/2600 (FDD 28,20,8,3,1,7); UMTS/HSPA/HSPA+: 850/900/2100; GSM/GPRS/EDGE: 850/900/1800/1900 Note: Indonesian configurations do not support LTE. Americas: LTE: 700/850/1800/1900, (FDD 12,17,5,2,4); UMTS/HSPA/HSPA+: 850/1700/1900 GSM/GPRS/EDGE: 850/900/1800/1900
GPS	Integrated, Autonomous, Assisted GPS (A-GPS), GLONASS, Beidou
Wireless PAN Data and Voice Communications	
Bluetooth	Bluetooth v4.2 Low Energy (LE)
Data Capture Specifications	
2D Imager	SE2100 imager (1D and 2D). SE4710 imager (1D and 2D).
Camera	Rear - 8 MP autofocus; f/2.4 aperture; rear camera flash LED generates balanced white light; supports Torch mode. (Available only on TC25 with WSE4710 scan engine).
2D Imager Engine (SE2100) Specifications	
Field of View	Horizontal - 41.5° Vertical - 31.7°
Image Resolution	640 horizontal X 480 vertical pixels
Roll	360°
Pitch Angle	± 60° from normal
Skew Tolerance	± 60° from normal
Ambient Light	Sunlight: 10,000 ft. candles (107,639 lux)
Focal Distance	From front of engine: 10.7 cm (4.2 in.)
Illumination System	LED: Ultra white Pattern Angle: 42° horizontal, 32.0° vertical at 50% intensity
2D Imager Engine (SE4710) Specifications	
Field of View	Horizontal - 42.0° Vertical - 28°
Image Resolution	1280 horizontal X 800 vertical pixels
Roll	360°

Table 18 *TC25 Technical Specifications (Continued)*

Item	Description
Pitch Angle	± 60° from normal
Skew Tolerance	± 60° from normal
Ambient Light	Sunlight: 10,000 ft. candles (107,639 lux)
Focal Distance	From front of engine: 19.4 cm (7.64 in.)
Laser Aiming Element	LED: 610 Aiming Dot Brightness Level: 130 fcd nominal
Illumination System	LEDs: Hyper Red 660 nm Pattern Angle: 53° horizontal, 32° vertical at 50% intensity

Table 19 *Data Capture Supported Symbologies*

Item	Description
1D barcodes	Code 39, Code 128, Code 93, Codabar, MSI, UPC/EAN, Interleaved 2 of 5, RSS
2D barcodes	PDF-417, Micro PDF-417, Composite, TLC-39, Datamatrix, QR Code, Micro QRCode, Maxicode, Postal codes, Aztec Code, Han Xin

Index

Numerics

5-slot charge only cradle kit 132

A

adaptive frequency hopping 127
adjust volume 60
airplane mode 29
alarms only 48
albums 89, 95
 deleting 90, 96
 getting information 90
 sharing 90
 working with 89
 working with albums 95
apn 122
approved cleanser 165
apps 51
 accessing 53
 adding shortcuts 43
 camera 74
 datawedge demonstration 80
 diagnostic tool 81
 files 87
 Gallery 88
 photos 94
 PTT Express 100
 RxLogger 102
 RxLogger Utility 105
 shortcuts 43
 sound recorder 105
arm mount 133
audio adapter 133
audio modes 60
automatically block sounds and vibrations 49

B

battery
 low battery notification 28
 monitor usage 28

battery charging 20
battery management 27
 battery level 27
 battery present status 27
battery optimization 29
Bluetooth 120
bluetooth 126
 change name 130
 disabling 129
 discovering devices 130
 enabling 129
 PIN 127
 power states 129
 profiles 128
 security 127
Bluetooth call 70
bullets 12

C

call forwarding 72
caller ID 72
camera 16, 51, 74
 photo settings 76
 rear camera photo settings 77
 rear camera video settings 78
 recording videos 75
 taking panoramic photos 75
 taking photos 74
 video settings 77
camera settings 76, 77
change bluetooth name 130
cleaning 165
cleaning instructions 165
conference call 65, 67
configuration 11
configurations 11
connect to WLAN 125
contacts 78
 adding 78
 deleting 79
 editing 78

conventions	
notational	12
cradle	
connector cleaning	166
cradle mount	132
cradle mounting adapter	133

D

data capture	11
datawedge	119
disable	119
enable	119
datawedge demonstration	80
DC line cord	134
device settings	
accessing	27
diagnostic tool	81
battery test information	84
bluetooth test information	86
gps test information	85
settings	84
system test information	85
wlan test information	85
wwan test information	85
disable bluetooth	129
disconnect host computer	59
discover bluetooth devices	130
display	
cleaning	166
display settings	30
display size	32
do not disturb feature	47

E

EAP	125
edit apn	122
emergency calling	60
enable bluetooth	129
extended power pack	132

F

feature	15
file transfer	58
files	87
folders	44
creating	44
naming	44
removing	45
font size	31

G

Gallery	88
cropping photos	91
deleting albums	90
deleting photos	92
deleting videos	93
getting album information	90
setting photos as contact icons	91
sharing albums	90
sharing photos	92
sharing videos	92
watching videos	92
working with albums	89
working with photos	91
working with videos	92
general sound setting	33
google	
account setup	23
mobile services	35

H

hand strap	133
handset mode	60
hands-free imager	108, 109
hard reset	57
harmful ingredients	165
headset	133
headset mode	60
home screen	35
moving items	44
rotation	37
home screen wallpaper	45

I

information, service	12
----------------------	----

K

keyboard	45
----------	----

L

light sensor	16
lock screen notifications	41
low battery notification	28

M

managing notifications	40
memory	11
messaging	52
microSD card	17, 24

monitor battery usage 28

N

notification icons 39
 notifications
 lock screen 41
 managing 40
 priority notifications only 48

O

operating system 11

P

pairing
 RS507/RS6000 hands-free imager 117
 using Bluetooth HID (RS507/RS6000) 117
 using simple serial interface(RS507/RS6000) .. 117
 panoramic 75
 photo transfer 59
 photos 94
 camera settings 76
 cropping 91, 97
 deleting 92, 99
 deleting albums 96
 deleting videos 99
 panoramic 75
 setting as contact icons 91, 98
 sharing 92, 98
 sharing videos 99
 taking 74
 viewing and browsing 96
 watching videos 99
 working with 91
 working with albums 95
 working with photos 96
 working with videos 99
 picklist 107
 power supply 133
 proximity sensor 16
 PTT button 15
 PTT Express
 audible indicators 100
 disabling communication 102
 enabling communication 101
 group calls 102
 notification icons 100
 private response 102
 PTT communication 101
 talk groups 101
 Voice Client 100

Q

quick access panel 41
 quick settings
 edit icons 42

R

related documents 12
 related software 12
 remove wi-fi 126
 resetting the device 57
 resetting 57
 ringtone 72
 RS507
 scanning 115
 RS507 scanning 115
 RS507/RS6000
 pairing 117
 pairing using Bluetooth HID 117
 pairing using simple serial interface 117
 RS6000
 scanning 114
 RS6000 scanning 114
 RxLogger 102
 RxLogger Utility 105

S

scan button 15
 scanning 109, 111, 112, 113
 considerations 109
 RS507 115
 RS6000 114
 screen font size 31
 screen protector 133
 screen rotation 30, 32
 security 124
 sensors 171
 setting
 camera 76, 77
 wakeup sources 34
 settings
 accessing 27
 automatically block sounds and vibrations 49
 camera photos 76
 camera videos 77
 display 30
 do not disturb 47
 general sound 33
 home screen wallpaper 45
 limit sounds and vibrations 47
 override do not disturb for specific apps 50
 priority notifications only 48
 SIM card 26

SMS	52
soft holster	133
soft reset	57
sound recorder	105
speaker	15
speaker mode	60
status bar	37
suspend mode	58
symbolologies	173

T

taking a panoramic photo	75
transferring files using USB	58
trigger handle	133
troubleshooting	167
TTY	72

U

USB	58
using the dialer	61

V

videos	
camera settings	77
deleting	93, 99
recording	75
sharing	92, 99
watching	92, 99
working with	92
working with videos	99
voicemail setup	72

W

wakeup sources	34
WEP	124
widgets	43
adding	43
wi-fi network	125
wireless local area network	120
WLAN	120
WPA	124
wrist mount	133

