

# REFERENCE MANUAL



> Matrix 210N™



Datalogic S.r.l.  
Via S. Vitalino 13  
40012 – Calderara di Reno  
Italy

Matrix 210N™ Reference Manual

Ed.: 11/2017

© 2015 - 2017 Datalogic S.p.A. and/or its affiliates ♦ ALL RIGHTS RESERVED. ♦ Without limiting the rights under copyright, no part of this documentation may be reproduced, stored in or introduced into a retrieval system, or transmitted in any form or by any means, or for any purpose, without the express written permission of Datalogic S.p.A. and/or its affiliates.

Datalogic and the Datalogic logo are registered trademarks of Datalogic S.p.A. in many countries, including the U.S.A. and the E.U.

Matrix 210N, ID-NET, DL.CODE and X-PRESS are trademarks of Datalogic S.p.A. and/or its affiliates. All other trademarks and brands are property of their respective owners.

Datalogic shall not be liable for technical or editorial errors or omissions contained herein, nor for incidental or consequential damages resulting from the use of this material.

07/11/17

# CONTENTS

---

<b>REFERENCES .....</b>	<b>vi</b>
Conventions.....	vi
Reference Documentation .....	vi
Support Through The Website.....	vi
Patents.....	vi
<b>COMPLIANCE.....</b>	<b>vii</b>
EMC Compliance.....	vii
Power Supply.....	vii
CE Compliance.....	vii
FCC Compliance .....	vii
EAC Compliance .....	viii
Laser Safety.....	viii
LED Safety.....	viii
<b>HANDLING.....</b>	<b>ix</b>
<b>GENERAL VIEW .....</b>	<b>xi</b>
<b>1 RAPID CONFIGURATION .....</b>	<b>1</b>
Step 1 – Connect the System .....	1
Step 2 – Mount and Position the Reader.....	5
Step 3 – X-PRESS Configuration for Software Adjustable Focus Models.....	6
Step 4 – X-PRESS Configuration for Fixed Focus Models.....	9
Step 5 – Installing DL.CODE Configuration Program .....	12
Step 5A – Ethernet Device Discovery.....	13
Step 5B – USB Device Discovery.....	16
Step 5C – Serial Device Discovery.....	19
Step 6 – Device Configuration .....	21
Step 7 – Test Mode .....	39
Advanced Reader Configuration.....	40
<b>2 INTRODUCTION .....</b>	<b>41</b>
2.1 Product Description .....	41
2.2 Indicators and Keypad Button.....	44
2.3 ID-NET.....	45
2.4 X-PRESS Human Machine Interface.....	47
2.4.1 X-PRESS Functions .....	47
2.4.2 Diagnostic Indication.....	49
2.5 Model Description .....	50
2.6 Accessories .....	51
2.7 Application Examples .....	52
2.7.1 Document Handling .....	52
2.7.2 Deformed or Overprinted Code Reading .....	52
2.7.3 Direct Part Marking.....	53
2.7.4 Ink-Jet Printing Technology .....	53
2.7.5 Laser Marking/Etching Technology .....	54
2.8 External Lighting Systems .....	54
<b>3 INSTALLATION .....</b>	<b>55</b>
3.1 Package Contents .....	55

3.2	Mechanical Dimensions.....	56
3.3	Mounting and Positioning Matrix 210N .....	59
<b>4</b>	<b>CBX ELECTRICAL CONNECTIONS .....</b>	<b>62</b>
4.1	Power Supply.....	63
4.2	Main Serial Interface.....	63
4.2.1	RS232 Interface.....	64
4.2.2	RS422 Full-Duplex Interface.....	65
4.3	ID-NET Interface.....	66
4.3.1	ID-NET Cables.....	66
4.3.2	ID-NET Response Time.....	67
4.3.3	ID-NET Network Termination.....	67
4.4	Auxiliary RS232 Interface .....	71
4.5	Inputs.....	72
4.6	Outputs .....	77
4.7	External Lighting Systems .....	79
4.8	On-Board Ethernet Interface.....	80
4.9	User Interface – Serial Host.....	80
<b>5</b>	<b>TYPICAL LAYOUTS .....</b>	<b>81</b>
5.1	Ethernet Connection .....	81
5.2	Serial Connection .....	83
5.3	Fieldbus Connection .....	84
5.4	Pass-Through .....	85
5.5	ID-NET Multidata Network (Pass-Through) .....	86
5.6	ID-NET Synchronized Network.....	87
5.7	USB Connection .....	90
<b>6</b>	<b>READING FEATURES.....</b>	<b>91</b>
6.1	Matrix Fixed Focus Models.....	91
6.2	FOV Calculation.....	92
6.3	Global FOV Diagrams.....	93
6.3.1	Software Adjustable Focus Models .....	94
6.4	Maximum Line Speed Calculation .....	95
<b>7</b>	<b>SOFTWARE CONFIGURATION .....</b>	<b>97</b>
7.1	DL.CODE System Requirements .....	97
7.2	Reader Configuration.....	97
7.2.1	Auto Calibration .....	98
7.2.2	Manual Calibration.....	99
7.2.3	Multi Image Acquisition Settings .....	102
7.2.4	Image Cropping .....	106
7.2.5	Direct Part Marking Applications.....	109
7.3	Pass-Through Configurations .....	114
7.4	Internal Network Configurations .....	115
7.4.1	Master Configuration .....	116
7.4.2	Multidata ID-NET Network Configurations.....	119
7.4.3	Synchronized ID-NET Network Configurations .....	124
7.4.4	Verify Master/Slave Synchronized Configuration .....	128
7.5	Backup and Restore Through DL.CODE .....	131
7.5.1	Backup.....	132
7.5.2	Restore .....	133
7.5.3	Replacement.....	133
7.6	Restore Defaults .....	134
7.6.1	Restore Default Startup Configuration.....	134

7.6.2	Restore Default Environment.....	135
7.6.3	Restore Factory Defaults .....	136
7.7	Diagnostic Alarms.....	136
7.8	Statistics .....	137
7.9	BM150 Display Module Configuration and Messages .....	138
7.9.1	Configuration Through DL.CODE .....	138
7.9.2	Accessing the HMI Interface Through Keypad and Display Menu .....	138
7.9.3	Display Messages.....	140
7.9.4	BM150 Backup and Restore Procedure .....	143
<b>8</b>	<b>MAINTENANCE .....</b>	<b>144</b>
8.1	Cleaning.....	144
<b>9</b>	<b>TROUBLESHOOTING .....</b>	<b>145</b>
9.1	General Guidelines .....	145
<b>10</b>	<b>TECHNICAL FEATURES.....</b>	<b>148</b>
<b>A</b>	<b>ALTERNATIVE CONNECTIONS .....</b>	<b>150</b>
	Power Com and I/O Connector.....	150
	On-Board Ethernet Connector .....	151
	ID-NET Network Termination.....	151
	Inputs .....	151
	Outputs .....	152
	User Interface – Serial Host.....	154
	<b>GLOSSARY.....</b>	<b>155</b>
	<b>INDEX.....</b>	<b>158</b>

# REFERENCES

---

## CONVENTIONS

This manual uses the following conventions:

"User" refers to anyone using a Matrix 210N reader.

"Reader" refers to the Matrix 210N reader.

"You" refers to the System Administrator or Technical Support person using this manual to install, configure, operate, maintain or troubleshoot a Matrix 210N reader.

## REFERENCE DOCUMENTATION

For further details refer to: the DL.CODE™ Help On Line, DL.CODE User's Guide, Matrix Reading Methods, provided as supplementary documentation on the DL.CODE mini-DVD (downloaded .zip file or mini-DVD accessory).

## SUPPORT THROUGH THE WEBSITE

Datalogic provides several services as well as technical support through its website. Log on to [www.datalogic.com](http://www.datalogic.com) and click on the **SUPPORT** link which gives you access to:

- **Downloads** by selecting your product model from the dropdown list in the Search by Product field for specific Data Sheets, Manuals, Software & Utilities, and Drawings;
- **Repair Program** for On-Line Return Material Authorizations (RMAs) plus Repair Center contact information;
- **Customer Service** containing details about Maintenance Agreements;
- **Technical Support** through email or phone.

## PATENTS

See [www.patents.datalogic.com](http://www.patents.datalogic.com) for patent list.

This product is covered by one or more of the following patents:

Utility patents: EP0996284B1, EP0999514B1, EP1014292B1, EP1128315B1, EP1396811B1, EP1413971B1, EP1804089B1, EP2315156B1, EP2517148B1, EP2649555B1, JP4435343B2, JP4571258B2, JP5192390B2, US6512218, US6616039, US6808114, US6997385, US7053954, US7387246, US8058600, US8113430, US8368000, US8743263, US8888003, US8915443, US9268982, US9430689, US9482793, ZL200680050007.8, ZL200880132595.9, ZL200980163411.X

## COMPLIANCE

---

For installation, use and maintenance it is not necessary to open the reader.

Only connect Ethernet and dataport connections to a network which has routing only within the plant or building and no routing outside the plant or building.

### EMC COMPLIANCE

In order to meet the EMC requirements:

- connect reader chassis to the plant earth ground by means of a flat copper braid shorter than 100 mm
- connect pin "Earth" of the CBX connection box to a good Earth Ground

### POWER SUPPLY

ATTENTION: READ THIS INFORMATION BEFORE INSTALLING THE PRODUCT

This product is intended to be installed by Qualified Personnel only.

This product is intended to be connected to a UL Listed Computer (LPS or "Class 2") which supplies power directly to the reader or a UL Listed Direct Plug-in Power Unit (rated 10 to 30 V, minimum 500 mA) marked LPS or "Class 2".

### CE COMPLIANCE

CE marking states the compliance of the product with essential requirements listed in the applicable European directive. Since the directives and applicable standards are subject to continuous updates, and since Datalogic promptly adopts these updates, therefore the EU declaration of conformity is a living document. The EU declaration of conformity is available for competent authorities and customers through Datalogic commercial reference contacts. Since April 20<sup>th</sup>, 2016 the main European directives applicable to Datalogic products require inclusion of an adequate analysis and assessment of the risk(s). This evaluation was carried out in relation to the applicable points of the standards listed in the Declaration of Conformity. Datalogic products are mainly designed for integration purposes into more complex systems. For this reason it is under the responsibility of the system integrator to do a new risk assessment regarding the final installation.

#### Warning

This is a Class A product. In a domestic environment this product may cause radio interference in which case the user may be required to take adequate measures.

### FCC COMPLIANCE

Modifications or changes to this equipment without the expressed written approval of Datalogic could void the authority to use the equipment.

This device complies with PART 15 of the FCC Rules. Operation is subject to the following two conditions: (1) This device may not cause harmful interference, and (2) this device must accept any interference received, including interference which may cause undesired operation.

This equipment has been tested and found to comply with the limits for a Class A digital device, pursuant to part 15 of the FCC Rules. These limits are designed to provide reasonable protection against harmful interference when the equipment is operated in a commercial environment. This

equipment generates, uses, and can radiate radio frequency energy and, if not installed and used in accordance with the instruction manual, may cause harmful interference to radio communications. Operation of this equipment in a residential area is likely to cause harmful interference in which case the user will be required to correct the interference at his own expense.

## EAC COMPLIANCE

Customs Union:

The CU Conformity certification has been achieved; this allows the Product to bear the Eurasian mark of conformity.

## LASER SAFETY

The Matrix 210N liquid lens models contain two aiming Laser LEDs used to position the reader.

This product conforms to the applicable requirements of IEC 60825-1 and complies with 21 CFR 1040.10 except for deviations pursuant to Laser Notice N° 50, date June 24, 2007. This product is classified as a Class 2 laser product according to IEC 60825-1 regulations.



**WARNING:** Use of controls or adjustments or performance of procedures other than those specified herein may result in exposure to hazardous visible laser light.

Disconnect the power supply when opening the device during maintenance or installation to avoid exposure to hazardous laser light. The laser beam can be switched on or off through a software command.



Produit(s) conforme selon 21CFR 1040.10 sauf des dérogations relatives à la Laser Notice N° 50, date Juin 24, 2007.

Dans le paquet il y a l'étiquette(s) pour les pays où le texte d'avertissement en français sont obligatoires. Le(s) mettre sur le produit à la place de la version anglaise.



Matrix 210N Warning Labels

Exemple d'étiquettes d'avertissement laser

## LED SAFETY

LED emission according to EN 62471



## HANDLING

---

The Matrix 210N is designed to be used in an industrial environment and is built to withstand vibration and shock when correctly installed, however it is also a precision product and therefore before and during installation it must be handled correctly to avoid damage.

- avoid that the readers are dropped (exceeding shock limits).

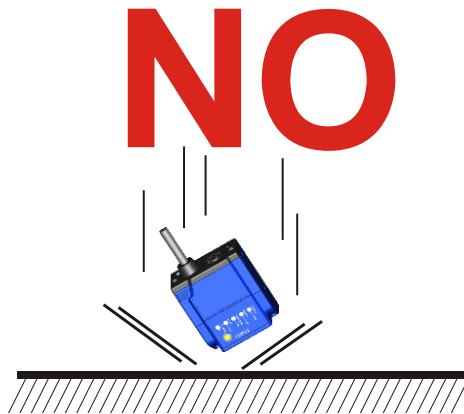

- do not fine tune the positioning by striking the reader or bracket.

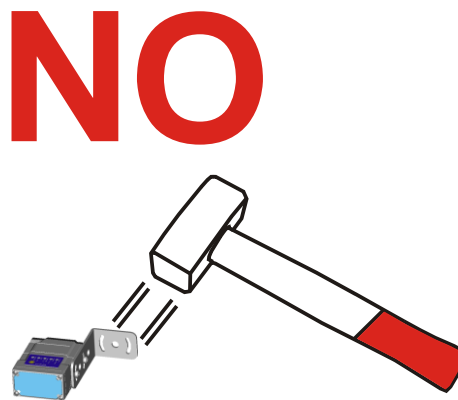

- do not weld the reader into position which can cause electrostatic, heat or reading window damage.

# NO

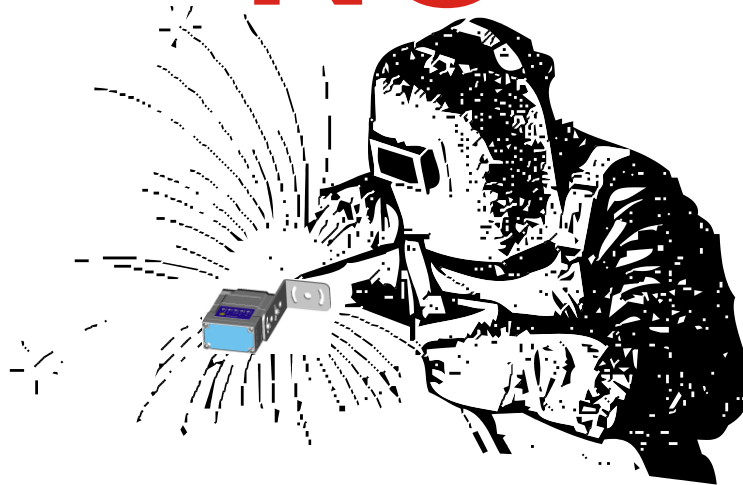

- do not spray paint near the reader which can cause reading window damage.

# NO

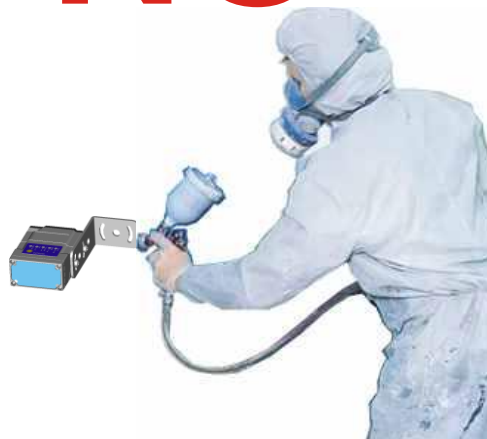

# GENERAL VIEW

## Matrix 210N™ Software Adjustable Focus (Liquid Lens) Models

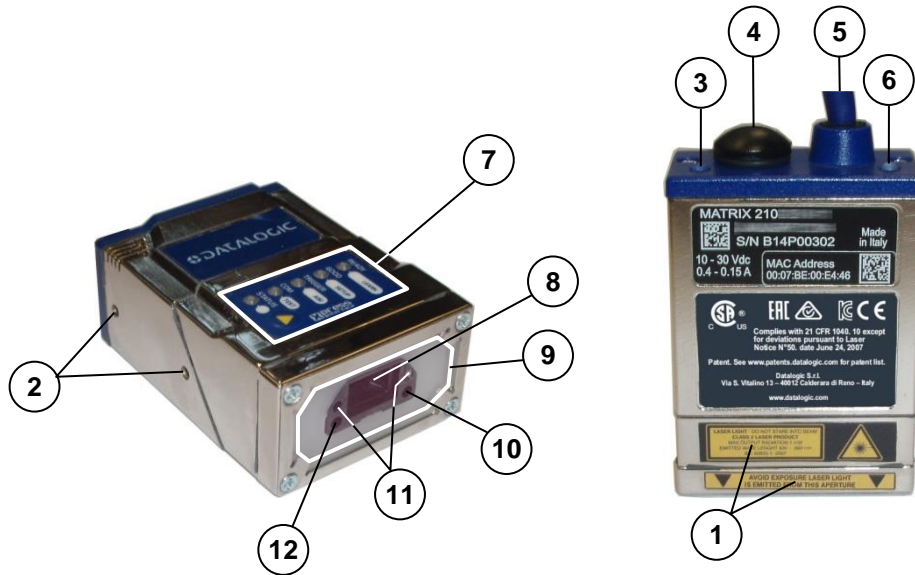

Figure A

- |                                   |  |                                |
|-----------------------------------|--|--------------------------------|
| ① Device Class and Warning Labels | ⑤ Power - Serial - I/O Cable Connector | ⑨ Internal Illuminator         |
| ② Mounting Holes (4)              | ⑥ Power On LED                         | ⑩ Good Read LED Spot (green)   |
| ③ Ethernet Connection LED         | ⑦ HMI X-PRESS Interface                | ⑪ Aiming System Laser Pointers |
| ④ Ethernet Connector              | ⑧ Lens                                 | ⑫ No Read LED Spot (red)       |

## Matrix 210N™ Fixed Focus Models



**Figure A**

- |   |   |   |
|---|---|---|
| <p>① Device Labels</p> <p>② Mounting Holes (4)</p> <p>③ Ethernet Connection LED</p> <p>④ Ethernet Connector</p> | <p>⑤ Power - Serial - I/O Cable Connector</p> <p>⑥ Power On LED</p> <p>⑦ HMI X-PRESS Interface</p> <p>⑧ Aiming System (Blue Ring)</p> | <p>⑨ Lens</p> <p>⑩ Internal Illuminator</p> <p>⑪ Good Read LED Spot (green)</p> |
|---|---|---|

# 1 RAPID CONFIGURATION

## STEP 1 – CONNECT THE SYSTEM

### Ethernet Connections

To connect the system in an Ethernet point-to-point configuration, you need the hardware indicated in Figure 1.

In this layout the data is transmitted to the Host from the Matrix 210N on-board Ethernet interface by using a **CAB-ETH-M0x** cable. There is no need to use a crossover adapter since Matrix 210N incorporates an autocross function.

Matrix 210N power and I/O device connections take place through the CBX connection box.

When One Shot or Phase Mode Operating mode is used, the reader is activated by an External Trigger (photoelectric sensor) when the object enters its reading zone.

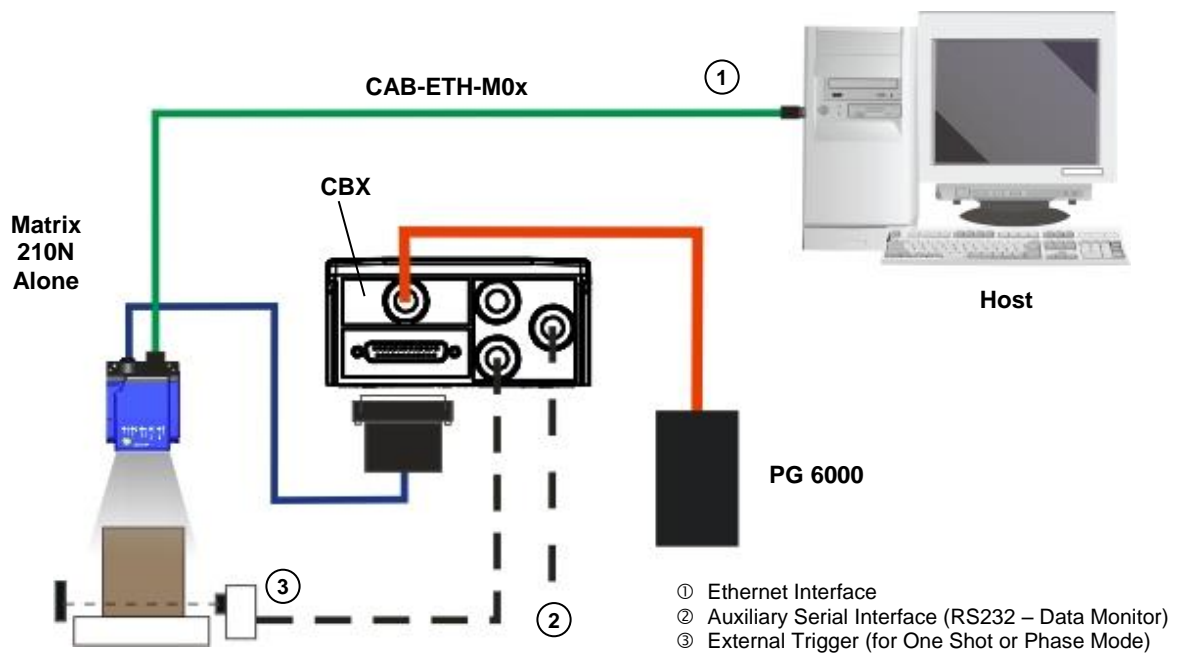

Figure 1 - Ethernet Point-to-Point Layout

## USB Connections

Matrix 210N USB models can be connected in a Point-to-Point layout to a local host through their USB cable. No external power supply is necessary.

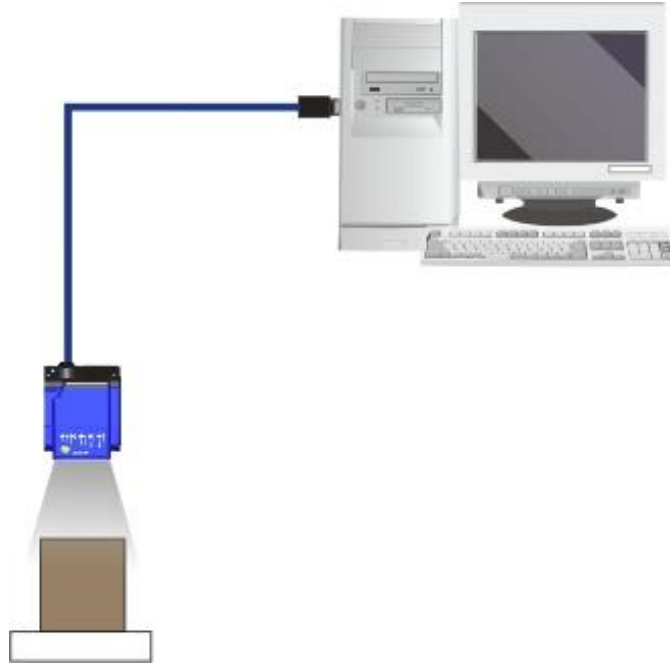

Figure 2 – Matrix 210N USB Point-to-Point Layout

## Serial Connections

To connect the system in a Serial point-to-point configuration, you need the hardware indicated in Figure 3.

In this layout the data is transmitted to the Host from the Matrix 210N main serial interface.

Matrix 210N power and I/O device connections take place through the CBX connection box.

When One Shot or Phase Mode Operating mode is used, the reader is activated by an External Trigger (photoelectric sensor) when the object enters its reading zone.

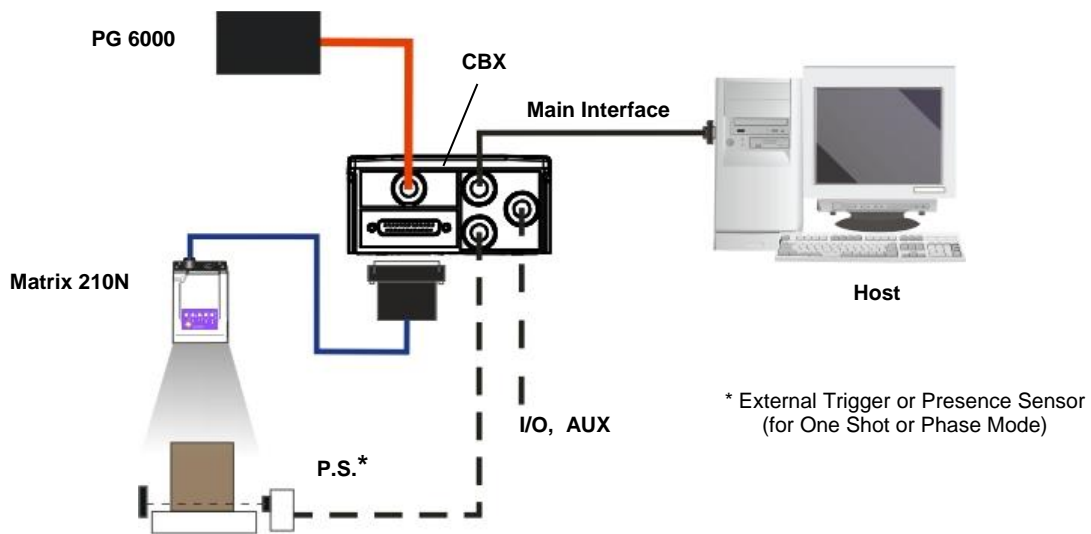

Figure 3 – Matrix 210N Serial Point-to-Point Layout



**NOTE:** For device configuration through DL.CODE, it is recommended to use the Ethernet interface (depending on your model).

All devices except dedicated USB models can be configured through their Main or Aux Serial port. However, through these interfaces, configuration is slower than the Ethernet interface and presents some limitations. It is recommended to use the Serial interface for configuration **only** if the Ethernet interface is not available.

## CBX100/CBX500 Pinout for Matrix 210N

The table below gives the pinout of the CBX100/CBX500 terminal block connectors. Use this pinout when the Matrix 210N reader is connected by means of the CBX100/CBX500:

CBX100/500 Terminal Block Connectors			
<b>Input Power</b>		<b>Outputs</b>	
Vdc	Power Supply Input Voltage +	+V	Power Source - Outputs
GND	Power Supply Input Voltage -	-V	Power Reference - Outputs
Earth	Protection Earth Ground	O1+	Output 1 +
		O1-	Output 1 -
<b>Inputs</b>		O2+	Output 2 +
+V	Power Source – External Trigger	O2-	Output 2 -
I1A	External Trigger A (polarity insensitive)	<b>Auxiliary Interface</b>	
I1B	External Trigger B (polarity insensitive)	TX	Auxiliary Interface TX
-V	Power Reference – External Trigger	RX	Auxiliary Interface RX
+V	Power Source – Inputs	SGND	Auxiliary Interface Reference
I2A	Input 2 A (polarity insensitive)	<b>ID-NET™</b>	
I2B	Input 2 B (polarity insensitive)	REF	Network Reference
-V	Power Reference – Inputs	ID+	ID-NET network +
<b>Shield</b>		ID-	ID-NET network -
Shield	Network Cable Shield		
<b>Main Interface</b>			
	<b>RS232</b>	<b>RS422 Full-Duplex</b>	
	TX	TX+	
	-	TX-	
	RX	*RX+	
	-	*RX-	
	SGND	SGND	

\* Do not leave floating, see par. 4.2.2 for connection details.



**CAUTION:** Do not connect GND, SGND and REF to different (external) ground references. GND, SGND and REF are internally connected through filtering circuitry which can be permanently damaged if subjected to voltage drops over 0.8 Vdc.



## STEP 2 – MOUNT AND POSITION THE READER

1. To mount the Matrix 210N, use the mounting brackets to obtain the most suitable position for the reader. The most common mounting configuration is shown in the figure below. Other mounting solutions are provided in par. 3.3.

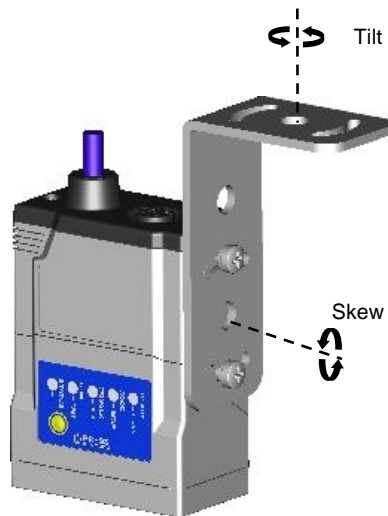

Figure 4 –Positioning with Mounting Bracket



**NOTE:** For applications where strong vibration or continuous bumps are present, it is recommended to use a double mounting bracket solution.

2. When mounting the Matrix 210N take into consideration these three ideal label position angles: **Pitch or Skew 10° to 20° and Tilt 0°**, although the reader can read a code at any tilt angle provided the code fits into the Field Of View (FOV).

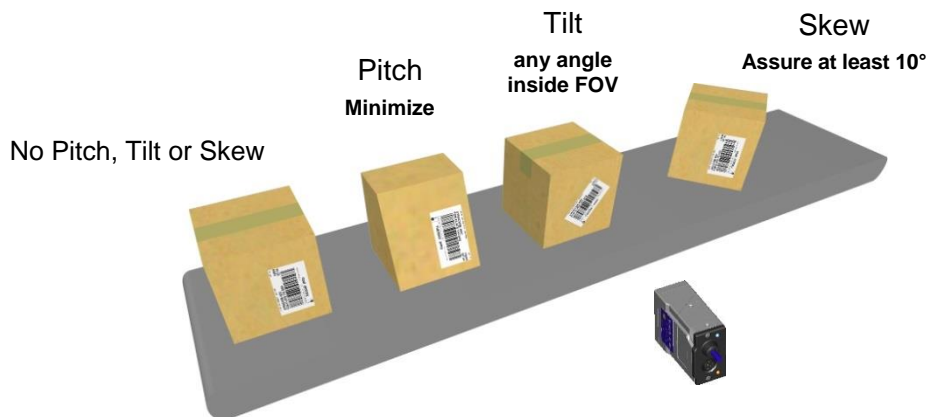

Figure 5 – Pitch, Tilt and Skew Angles

3. Refer to the Reading Features table in chp. 6 to determine the distance your reader should be positioned at.



**NOTE:** Rapid Configuration of the Matrix 210N reader can be made **either** through the X-PRESS™ interface (steps 3 or 4) which requires no PC connection, **or** by using the DL.CODE Configuration Program (steps 5-6). Select the procedure according to your needs.

## STEP 3 – X-PRESS CONFIGURATION FOR SOFTWARE ADJUSTABLE FOCUS MODELS



**NOTE:** For Fixed Focus models go to Step 4.

Matrix 210N liquid lens models provide a built-in laser pointer aiming system to aid reader positioning. For these models the autofocus feature is also incorporated into this function. The aiming system is accessed through the X-PRESS Interface.

1. Power the reader on. During the reader startup (reset or restart phase), all the LEDs blink for one second. On the reverse side of the reader near the bracket, the “POWER ON” LED (blue) indicates the reader is correctly powered.
2. Place the **Grade A Barcode Test Chart** in front of the reader at the correct reading distance for your application. See the Global FOV Diagrams in chapter 6 for reference.
3. Enter the Aim/Autofocus function by pressing and holding the X-PRESS push button until the Aim LED is on.
4. Release the button to enter the Aim function. The laser pointers turn on, and the Autofocus procedure begins, see Figure 6. The Aim LED will blink until the procedure is completed.

**Within 3 seconds (before the reader flashes), center one of the larger codes on the aiming system pointers (the code must not move during this procedure).**

The Autofocus procedure ends when the Reading Distance and PPI values are successfully saved in the reader memory, the Aim LED will stop blinking and Matrix 210N emits 3 high pitched beeps.

If the Autofocus cannot be reached after a timeout of about 3 (three) minutes Matrix 210N will exit without saving the parameters to memory, the Aim LED will stop blinking and in this case Matrix 210N emits a long low pitched beep.

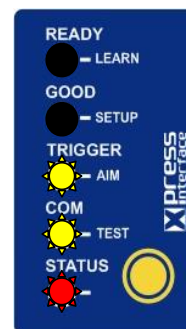
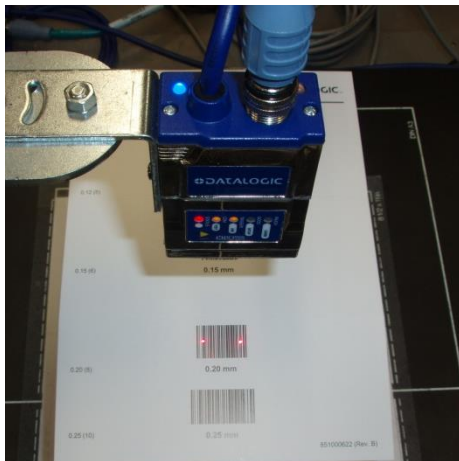

Figure 6 – X-PRESS Interface: Aim/Autofocus Function



**NOTE:** You can exit the Aim/Autofocus function at any time by pressing the X-PRESS push button once. After a short delay the autofocus procedure is cancelled and the laser pointers turn off.

Once Matrix 210N is focused at the correct reading distance, you must configure it for optimal code reading relative to your application.

## Aim

- Repeat the Aim function, but now position **a single code from your application** at the center of the FOV (equidistant from the laser pointers).

The reader may start flashing and try to perform autofocus.

- To avoid overwriting the distance and PPI values previously set, exit the Aim function by pressing the X-PRESS push button once.

After a short delay the Aim function is cancelled and the laser pointers turn off.

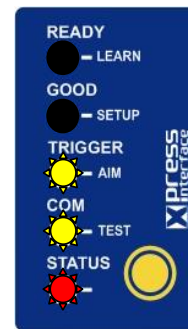

Figure 7 – X-PRESS Interface: Aim Function

## Setup

- Enter the Setup function by pressing and holding the X-PRESS push button until the Setup LED is on.
- Release the button to enter the Setup function. The Setup LED will blink until the procedure is completed.

The Setup procedure ends when the Image Acquisition parameters are successfully saved in the reader memory, the Setup LED will stop blinking and Matrix 210N emits 3 high pitched beeps.

If the calibration cannot be reached after a timeout of about 5 (five) seconds Matrix 210N will exit without saving the parameters to memory, the Setup LED will stop blinking and in this case Matrix 210N emits a long low pitched beep.

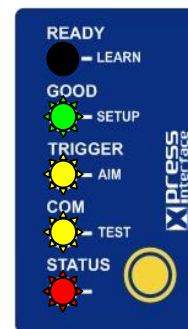

Figure 8 – X-PRESS Interface: Setup Function

## Learn

9. Enter the Learn function by pressing and holding the X-PRESS push button until the Learn LED is on.
10. Release the button to enter the Learn function. The Learn LED will blink until the procedure is completed.

The Learn procedure ends when the Image Processing and Decoding parameters for **a single code** are successfully saved in the reader memory, the Green Spot is activated, the Learn LED will stop blinking and Matrix 210N emits 3 high pitched beeps<sup>1</sup>.

If the autolearning cannot be reached after a timeout of about 3 (three) minutes Matrix 210N will exit without saving the parameters to memory, the Learn LED will stop blinking and in this case Matrix 210N emits a long low pitched beep.

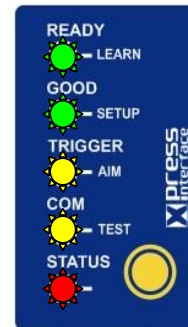

Figure 9 – X-PRESS Interface: Learn Function



**NOTE:** When using X-PRESS or the BM150 menu to perform the Auto-learn, only **a single code** can be configured (successive Learns will substitute the current code). To configure multiple code symbologies, use the DL.CODE Auto-learn procedure.



**NOTE:** You can always exit from any X-PRESS function at any time by pressing the X-PRESS push button once. After a short delay the procedure is cancelled.



**NOTE:** If you have used this procedure to configure Matrix 210N go to step 7.

<sup>1</sup> The Learn procedure will not recognize the following symbologies: Postal Codes, Pharmacode, MSI, Standard 2 of 5, Matrix 2 of 5.

## STEP 4 – X-PRESS CONFIGURATION FOR FIXED FOCUS MODELS



**NOTE:** For Software Adjustable Focus models go to Step 3.

Matrix 210N™ fixed focus models provide a built-in aiming system to aid reader positioning. The aiming system is accessed through the X-PRESS Interface.

1. Power the reader on. During the reader startup (reset or restart phase), all the LEDs blink for one second. On the connector side of the reader near the cable, the “POWER ON” LED (blue) indicates the reader is correctly powered.
2. Enter the Aim/Locate function by pressing and holding the X-PRESS push button until the Aim LED is on.
3. Release the button to enter the Aim function. The aiming system turns on see Figure 10.
4. Place the **application specific code** in front of the reader at the reading distance indicated for your model in the Reading Features Fixed Focus table in par.6.1, centering it in the aiming system indicator.

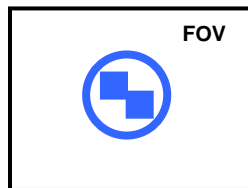

Figure 10 – Aiming Function Using The Blue Ring

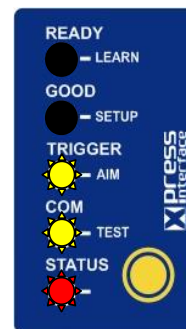

Figure 11 – X-PRESS Interface: Aim Function

5. Exit the Aim function by pressing the X-PRESS push button once. The aiming system turns off.

Once Matrix 210N is focused at the correct reading distance, you must configure it for optimal code reading relative to your application.

## Setup

5. Enter the Setup function by pressing and holding the X-PRESS push button until the Setup LED is on.
6. Release the button to enter the Setup function. The Setup LED will blink until the procedure is completed.

The Setup procedure ends when the Image Acquisition parameters are successfully saved in the reader memory, the Setup LED will stop blinking and Matrix 210N emits 3 high pitched beeps.

If the calibration cannot be reached after a timeout of about 5 (five) seconds Matrix 210N will exit without saving the parameters to memory, the Setup LED will stop blinking and in this case Matrix 210N emits a long low pitched beep.

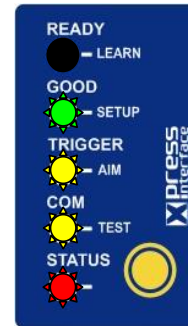

Figure 12 – X-PRESS Interface: Setup Function

## Learn

7. Enter the Learn function by pressing and holding the X-PRESS push button until the Learn LED is on.
8. Release the button to enter the Learn function. The Learn LED will blink until the procedure is completed.

The Learn procedure ends when the Image Processing and Decoding parameters for **a single code** are successfully saved in the reader memory, the Green Spot is activated, the Learn LED will stop blinking and Matrix 210N emits 3 high pitched beeps<sup>2</sup>.

If the autolearning cannot be reached after a timeout of about 3 (three) minutes Matrix 210N will exit without saving the parameters to memory, the Learn LED will stop blinking and in this case Matrix 210N emits a long low pitched beep.

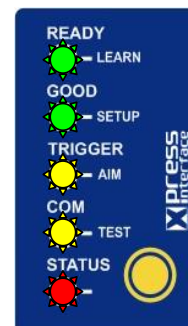

Figure 13 – X-PRESS Interface: Learn Function



**NOTE:** When using X-PRESS or the BM150 menu to perform the Auto-learn, only **a single code** can be configured (successive Learns will substitute the current code). To configure multiple code symbologies, use the DL.CODE Auto-learn procedure.

<sup>2</sup> The Learn procedure will not recognize the following symbologies: Postal Codes, Pharmacode, MSI, Standard 2 of 5, Matrix 2 of 5.



**NOTE:** You can always exit from any X-PRESS function at any time by pressing the X-PRESS push button once. After a short delay the procedure is cancelled.



**NOTE:** If you have used this procedure to configure Matrix 210N go to step 7.

### Reset Reader to Factory Default Environment (Optional)

If it ever becomes necessary to reset the reader's Environment parameters to their factory default values, you can perform this procedure by holding the X-PRESS push button pressed while powering up the reader. **You must keep the X-PRESS push button pressed until all LEDs blink simultaneously for about 3 seconds. Release and re-press the button during this LED blinking sequence.**

All the device's Environment parameters are reset including the default IP Address. The Matrix 210N emits 3 high pitched beeps and after a few seconds enters run mode.

Any previously saved configurations on the device will remain in memory, but the Default configuration is set as the startup configuration.



**NOTE:** If you release the button while the LEDs are all on continuously (after the blinking phase), the reader will enter the Loader program sequence and the LEDs will begin to cycle through various patterns. Just cycle power to return to run mode.

## STEP 5 – INSTALLING DL.CODE CONFIGURATION PROGRAM



**CAUTION:** DL.CODE does not currently support Windows Embedded (often used in industrial PCs and/or PLCs).

DL.CODE is a Datalogic reader configuration tool providing several important advantages:

- Intuitive Graphical User Interface for rapid configuration;
- Defined configuration directly stored in the reader;
- Discovery and IP address setting features to facilitate remote configuration
- Device Monitoring
- Device Driver Installation

### To install DL.CODE:

1. On the PC that will be used for configuration, (running Windows XP SP3, 7, 8, or 10), download the DL.CODE mini-DVD .zip file. Extract the files maintaining the folder structure and run the **start.hta** file to access the installation pop-up. Click on the **Install DL.CODE** link to run the installation program and follow the installation procedure.



**NOTE:** To configure Serial model devices, check the Matrix RS232 Serial Port Driver installation box in the Welcome window of the DL.CODE Installer. In this case it is recommended to reboot the PC after DL.CODE installation.

The Matrix USB Diver selection is not for Matrix 210N devices, see step 5B.



**NOTE:** To perform a “silent” installation (without user input), see the DL.CODE User’s Guide.

2. When the installation is complete the DL.CODE entry is created in the Start>Programs bar under “Datalogic” as well as a desktop icon. Double-click the desktop icon to run it.

Depending on your Matrix 210N model, you can connect to the DL.CODE configuration environment through one of the following interfaces:

Model	Interface	Instructions
Matrix 210N xxx-x1x	Ethernet Configuration	STEP 5A
Matrix 210N xxx-x2x	USB Configuration	STEP 5B
Matrix 210N xxx-x0x	Serial Configuration *	STEP 5C

\* All devices except dedicated USB models can be configured through their Main or Aux Serial port. However, through these interfaces, configuration is slower than the Ethernet interface and presents some limitations. It is recommended to use the Serial interface for configuration **only** if no other interface is available.



## STEP 5A – ETHERNET DEVICE DISCOVERY

The following configuration procedure assumes a laptop computer, running DL.CODE, is connected to a factory default reader through the Ethernet port. See Step 1 – Connect the System.

The User Interface opens and displays a list of all the devices belonging to the Local Area Network. DL.CODE has a discovery feature to accomplish this task.

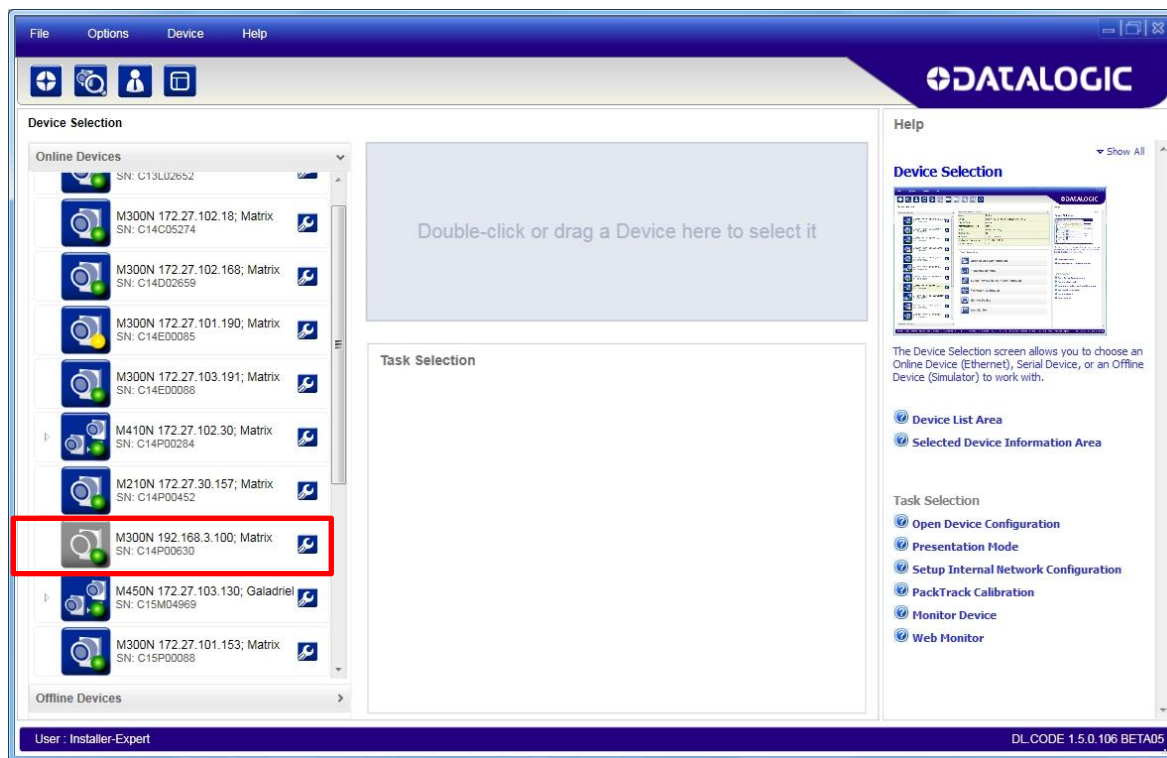



Figure 14 – Device Discovery

The discovery feature will also show devices not belonging to the LAN and display them in grey (see Figure 14).

3. First the device must be added to the LAN by aligning its IP Address to the network. The network administrator should provide valid LAN address(es).
4. Find your device in the list by matching its serial number (SN) then click on the device wrench icon  to open the Device Environment Configuration window.
5. Change the Ethernet Settings (IP Address, Subnet Mask, Gateway Address etc.) according to the network requirements.

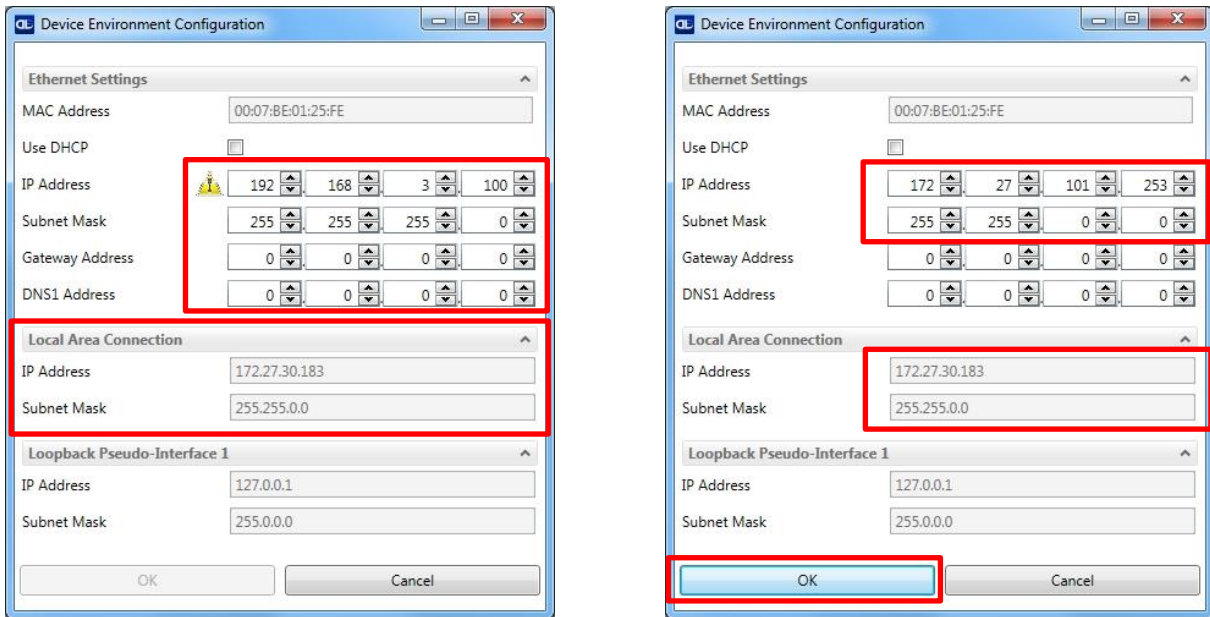
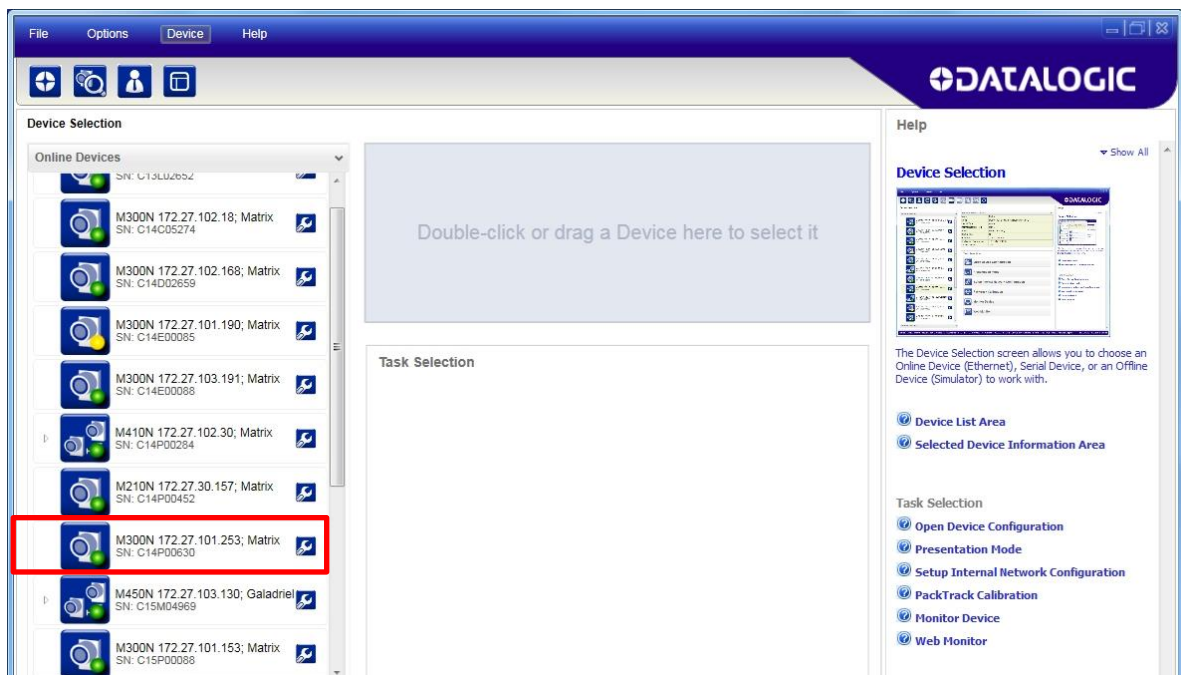

Figure 15 - Device Environment Configuration Window

- Click OK; the device will reappear in the list of Online Devices (in color) meaning it is now part of the LAN and can be configured. The new IP address will also be displayed.



7. Double-click on or drag the device icon into the Selected Device Information Area. Details about the device will be displayed in this area.

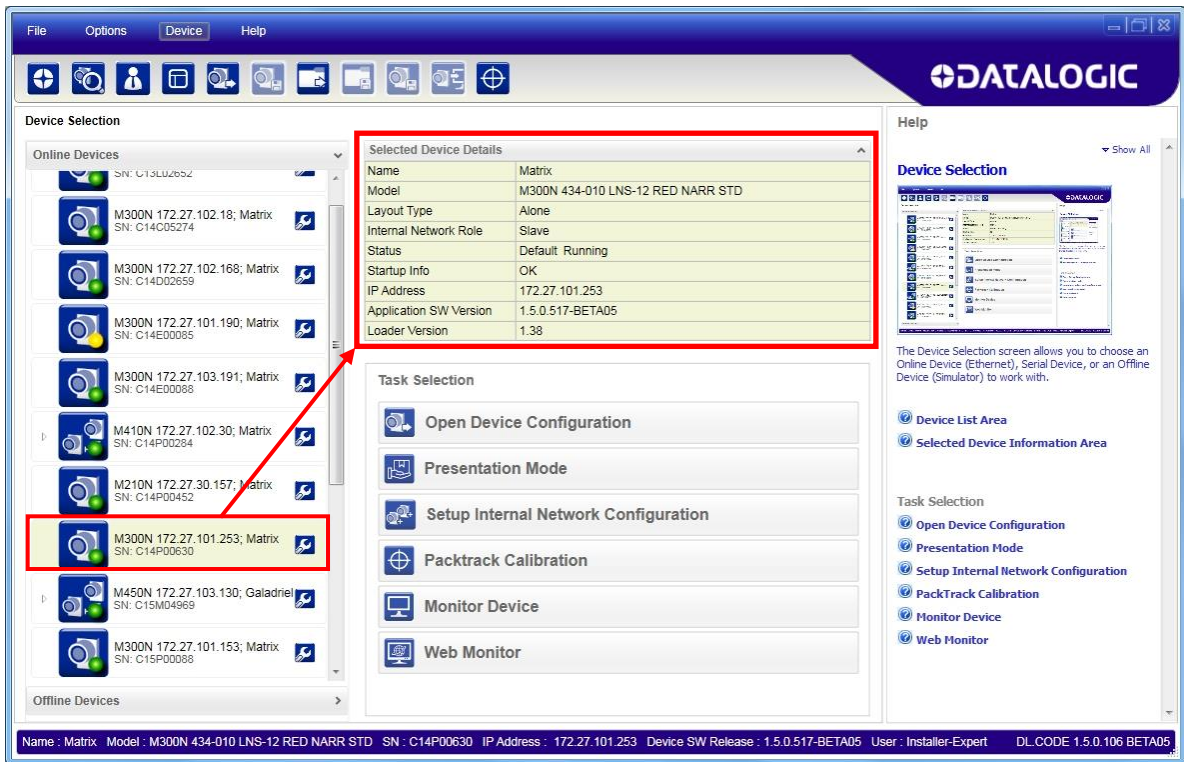

Figure 16 – DL.CODE Opening Window



**NOTE:** After device discovery, configure your device through DL.CODE as described in Step 6 – Device Configuration.

## STEP 5B – USB DEVICE DISCOVERY

The following configuration procedure assumes that a laptop computer running DL.CODE is connected to a Matrix 210N USB model factory default reader through the USB port.

Matrix 210N USB devices require their virtual COM port driver to be installed on the PC being used for configuration. This can be done in two ways:

- If the PC used for configuration is connected to internet and has access to Windows Update, then the correct device driver will automatically be installed.
- If the PC used for configuration is not connected to internet and does not have access to Windows Update, then the correct device driver can be installed from the DL.CODE mini-DVD (downloaded zip file or mini-DVD accessory). The installation file is located in the Software\ SW Utilities\USB Virtual COM Port Drivers directory. See the paragraph below for installation instructions.



**NOTE:** The Matrix USB Diver selection box in the Welcome window of the DL.CODE Installer. is not for Matrix 210N devices.

The USB Virtual COM Port Driver allows sending serial data using the Matrix 210N USB port. A different virtual COM Port will be assigned to each connected reader.

### Installing the USB Virtual COM port drivers:

1. Double-click on one of the following files to launch the correct USB Virtual COM Port Driver Installer for your PC.
  - Windows XP//7 (x32) = "DPInst.exe"
  - Windows 7, 8, 10 (x64) = "DPInstx64.exe"

The driver will be installed.

For updated drivers or more details go to [ftdichip.com/Drivers/VCP.htm](http://ftdichip.com/Drivers/VCP.htm).

Starting from DL.CODE 1.4.0, serial port communication is supported for device discovery and configuration. This allows dedicated Matrix 210N USB communication models to be configured through DL.CODE.

**This feature is not enabled by default**, so the first thing to do is to enable it through the UI Settings window.

1. From the main menu open the Options>UI Settings window.
2. Click on the Global Settings menu and scroll down to the Find Devices tab.
3. Check the **Enable Serial Device Discovery** box. Scroll down to see the following selections.
4. For Matrix 210N USB models the baud rate is fixed at 115200. Select **115200**.

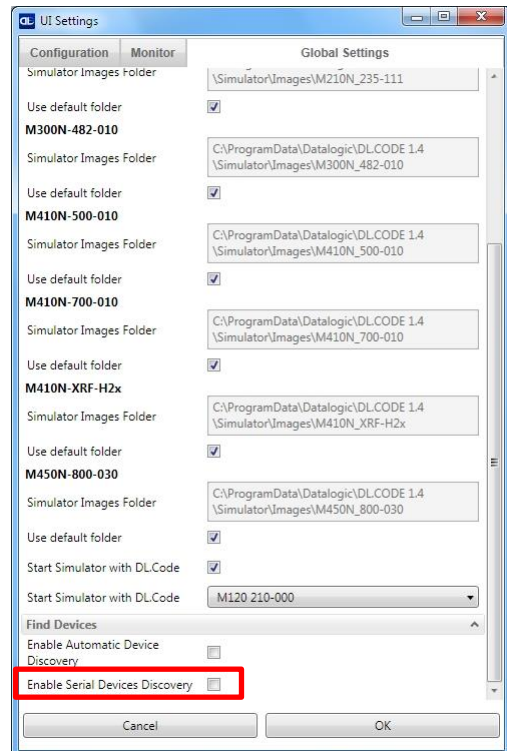
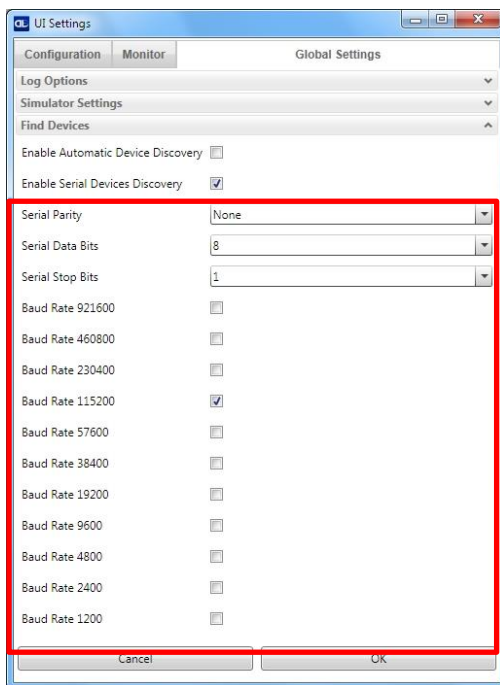

5. Click OK to return to DL.CODE and click on the Getting Started icon.

- Open the Serial devices tab and double-click on or drag the device icon into the Selected Device Information Area.

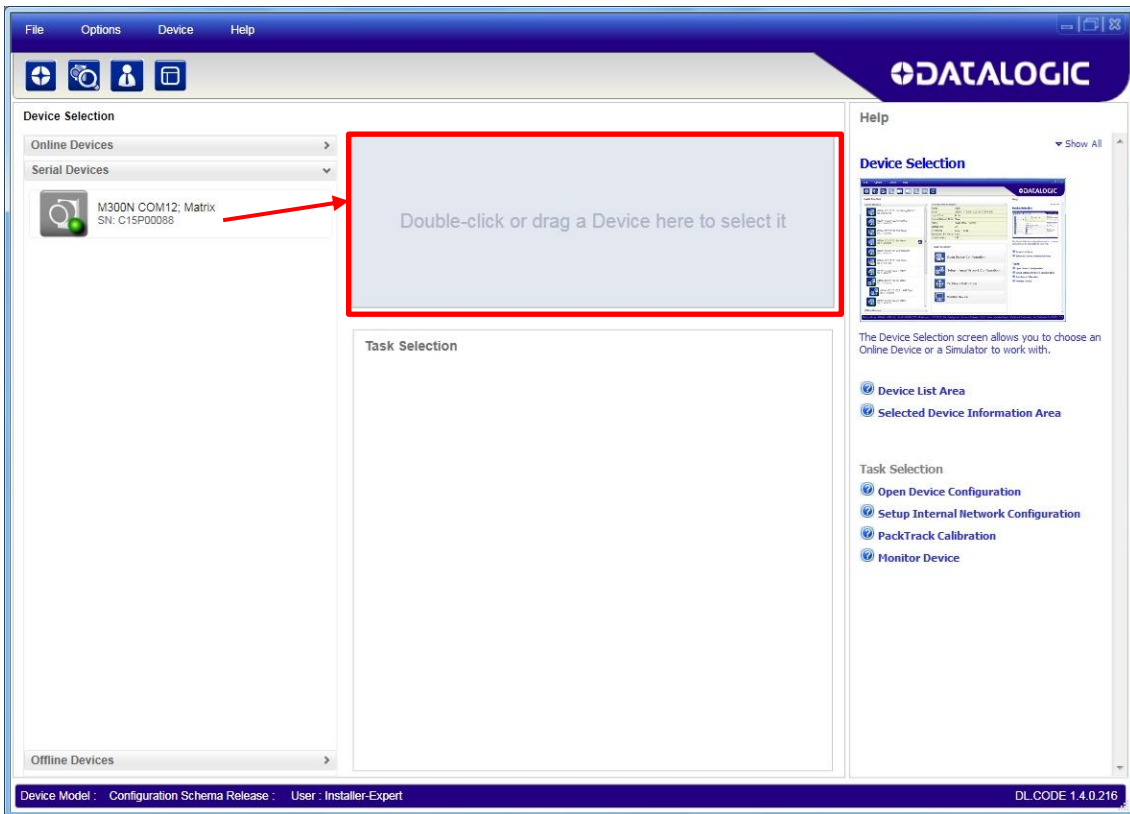

The device is now connected to the DL.CODE Configuration environment. Configure your device through DL.CODE as described in Step 6 – Device Configuration.

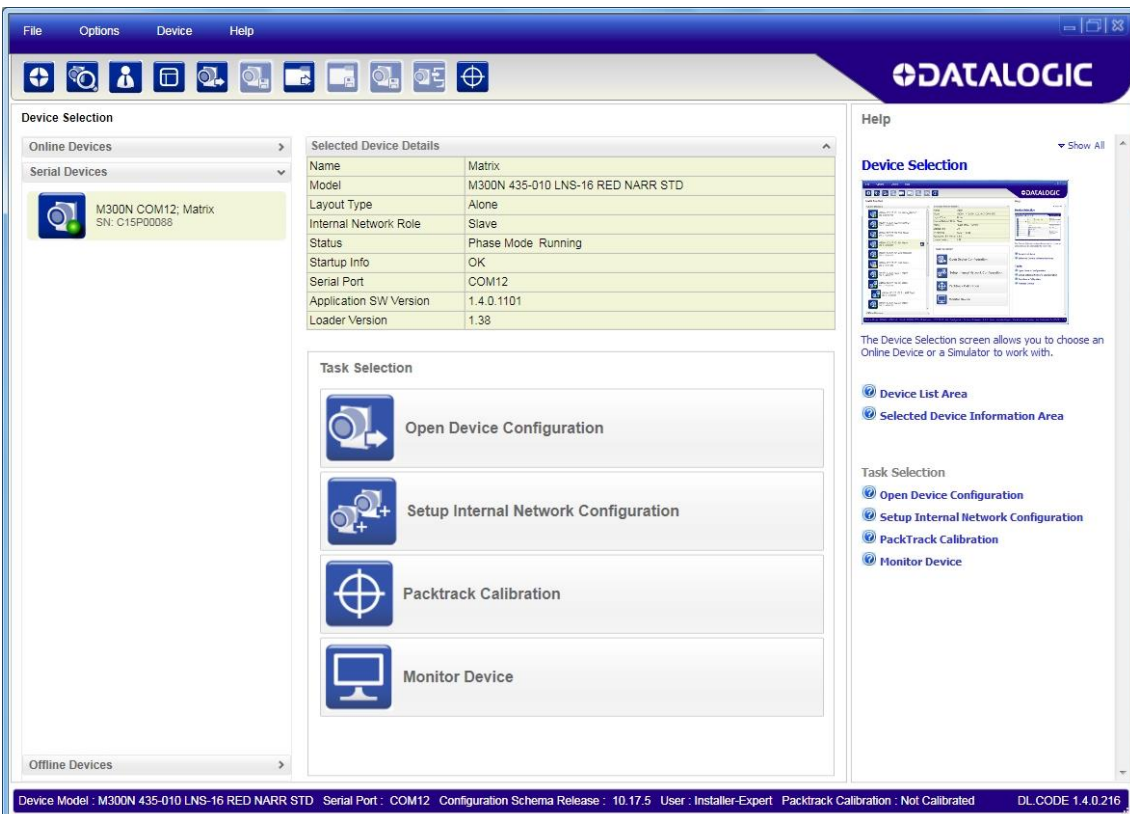

## STEP 5C – SERIAL DEVICE DISCOVERY

Starting from DL.CODE 1.4.0, serial port communication is supported for device discovery and configuration. This allows dedicated serial communication models to be configured through DL.CODE.



**NOTE:** Although this feature allows all devices to be configured through their Serial Interface, be aware that transmission speeds and some DL.CODE features are limited when using this interface. It is always advised to use the Ethernet interface whenever possible.

**This feature is not enabled by default**, so the first thing to do is to enable it through the UI Settings window.

1. From the main menu open the Options>UI Settings window.
2. Click on the Global Settings menu and scroll down to the Find Devices tab.
3. Check the **Enable Serial Device Discovery** box. Scroll down to see the following selections.
4. Select the Serial communication parameters according to your application. Default is **115200**.

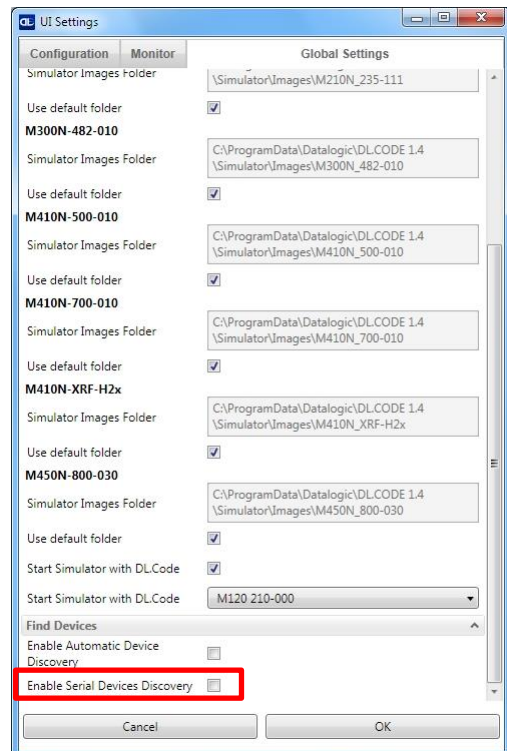
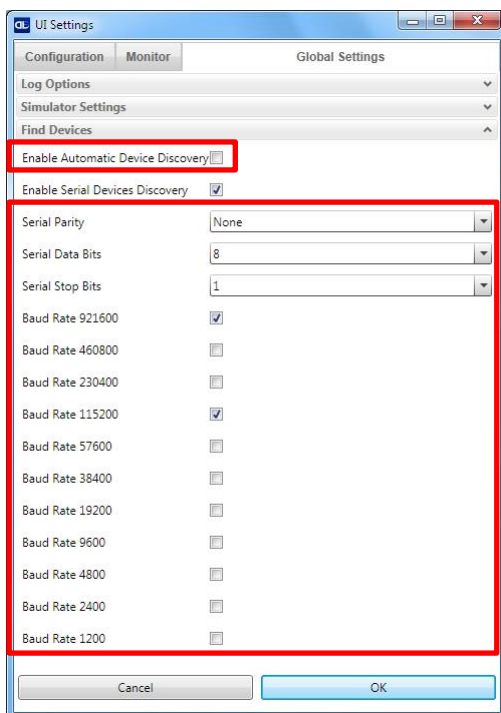

**NOTE:** If you're not sure of the Serial baud rate you can also check the **Enable Automatic Device Discovery** box which for serial devices will try communication at all baud rates, but only at **No** parity, **8** data bits; **1** stop bit. Enabling this parameter can notably lengthen Discovery time, therefore in general it is better to disable it to increase Discovery efficiency.

5. Click OK to return to DL.CODE and click on the Getting Started icon.

- Open the Serial devices tab and double-click on or drag the device icon into the Selected Device Information Area.

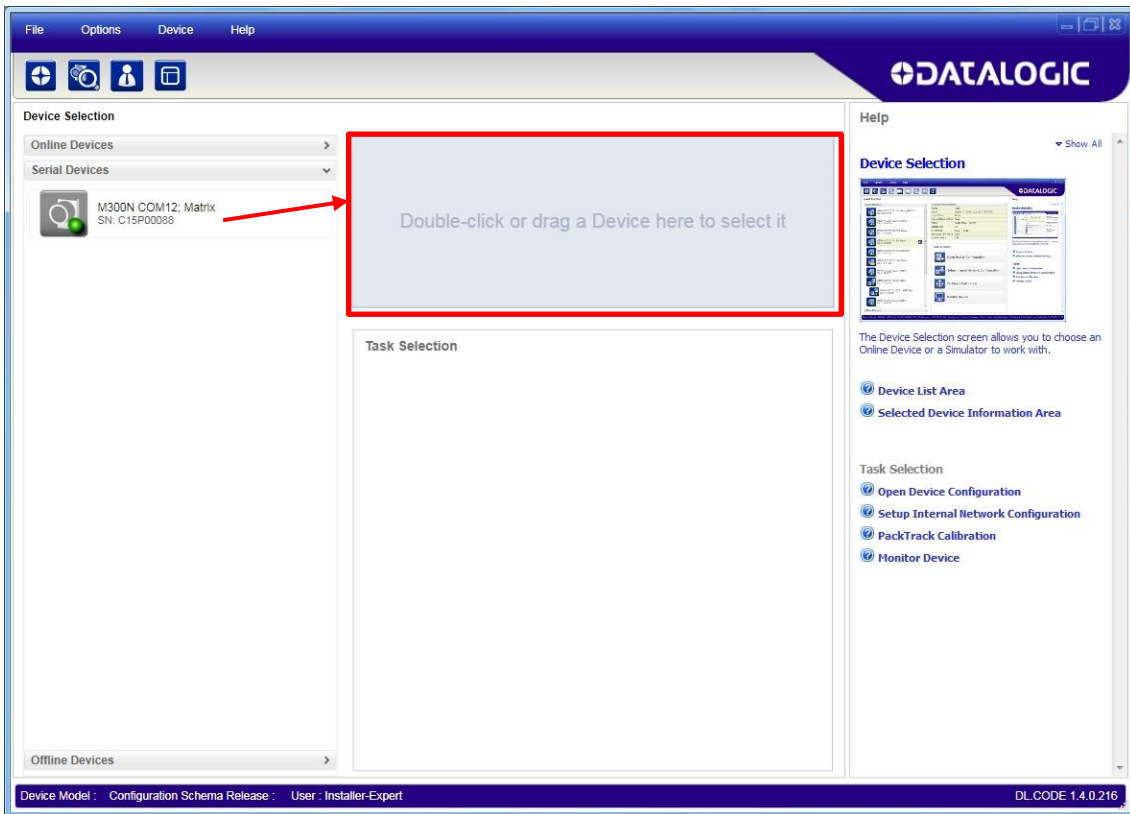

The device is now connected to the DL.CODE Configuration environment. Configure your device through DL.CODE as described in Step 6 – Device Configuration.

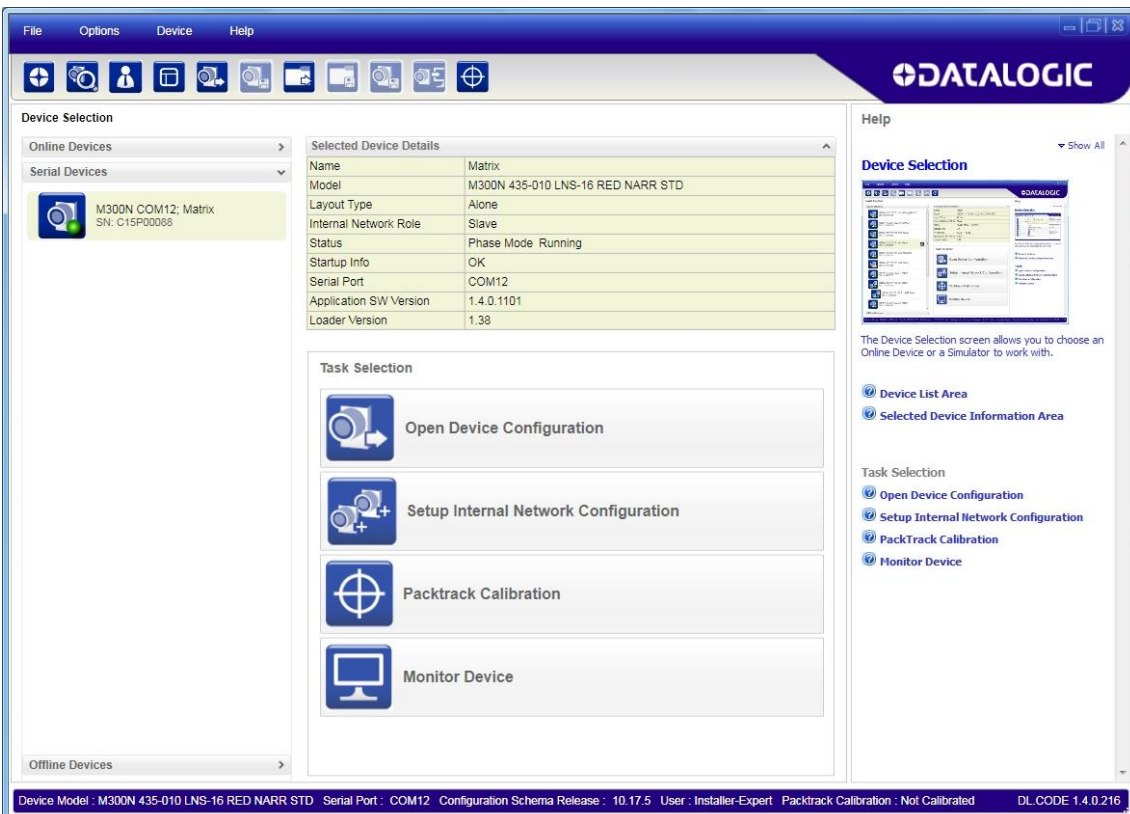



## STEP 6 – DEVICE CONFIGURATION

### Automatic or Advanced Setup

**Automatic Setup** provides an automatic procedure for setting: optical/illumination, reading distance (for software adjustable focus liquid lens models), and code definition parameters to obtain the most stable decoding conditions for a single code symbology based on the images presented to the reader. It can be set to include Image Filters if necessary. See the table below for codes and filters managed by Automatic Setup. Automatic Setup is especially useful for DPM applications.

Enabled 1D Codes	Enabled 2D Codes	Enabled Filters
CODE 128 EAN 128 CODE 39 CODE 93 CODABAR PDF417 MICRO PDF417 GS1 DATABAR GS1 DATABAR STACKED GS1 DATABAR LIMITED GS1 DATABAR EXPANDED GS1 DATABAR EXPANDED STACKED UPCEAN FAMILY EAN13 UPCEAN FAMILY EAN8 UPCEAN FAMILY UPCA UPCEAN FAMILY UPCE	DATAMATRIX ECC 200 QR MICRO QR AZTEC MAXICODE DOTCODE	ERODE 3x3, 5x5 and 7x7 DILATE 3x3, 5x5 and 7x7 SMOOTHING

**Advanced Setup** provides access to the complete array of optical/illumination, software and manual focusing adjustment, and code definition parameters that can be fine-tuned semi-automatically and manually to obtain the best results for applications of any complexity.





**NOTE:** If your application requires multiple code symbologies, multiple image settings, Code Grading or other parameter settings for decoding, then use the Advanced Setup, see page 24 or 31.

### Automatic Setup

To begin configuration, the reader must be correctly mounted so that its Field of View covers the application reading area.

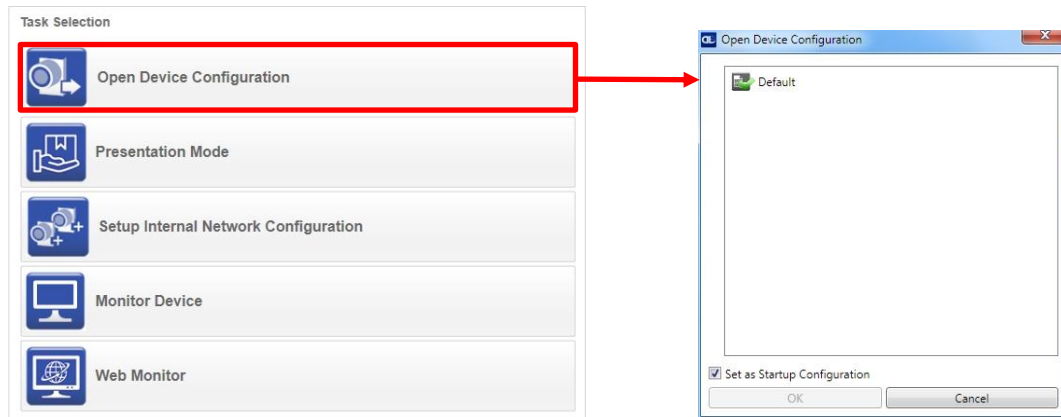
1. From the Task Area select Open Device Configuration.
2. The Open Device Configuration window opens showing the list of currently saved configurations (jobs) saved on the device. For new devices, the only saved job is the Default configuration. Click OK. The device enters run mode and begins acquiring images.



3. Place the application code in front of the reader at the correct application reading distance.
4. Click on the Pause button  to stop image acquisition.

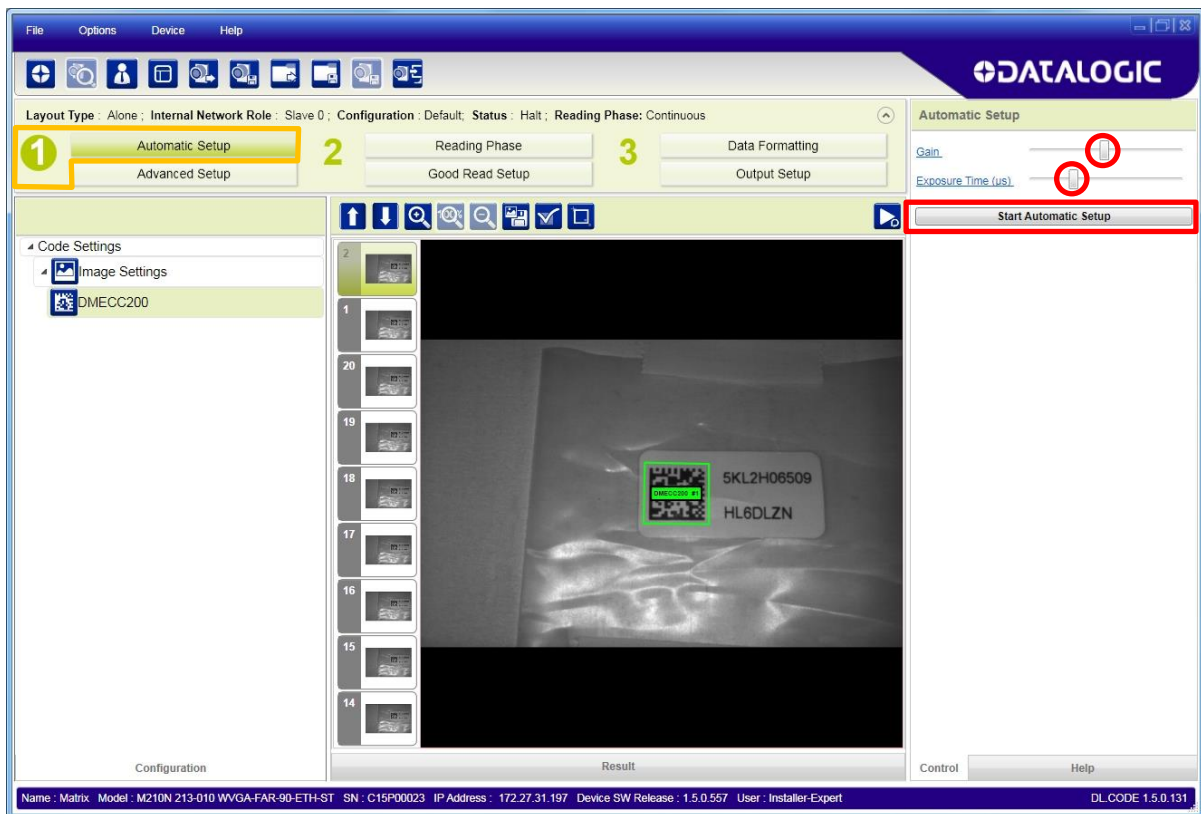

**NOTE:** If the image display area is too dark to see the images being captured, you can drag the Gain and Exposure Time sliders (circled in red in the figure above) to the right to increase visibility. This will not affect Automatic Setup.

5. Click on the **Start Automatic Setup** button. The following window is displayed.

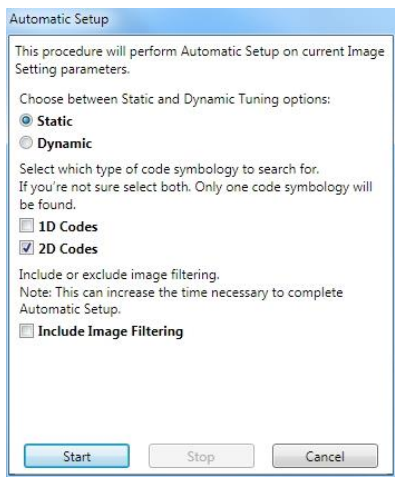

6. Select the correct reading conditions: Static or Dynamic Tuning, 1D or 2D code, Include Image Filtering (to find the best decoding condition).
7. Click Start to begin the procedure. The reader begins acquiring images. At the end of the procedure the **Status: Completed** message appears. You can Close the Automatic Setup window.



Your reader is now optimized for decoding. Continue with the Reading Phase configuration described on page 35.

## Advanced Setup for Software Adjustable Focus Models (Liquid Lens)





**NOTE:** For Fixed Focus models go to page 31 then continue the configuration on page 35 (**Reading Phase**).

To begin configuration, the reader must be correctly mounted at the correct reading distance for your application so that its Field of View covers the application reading area.

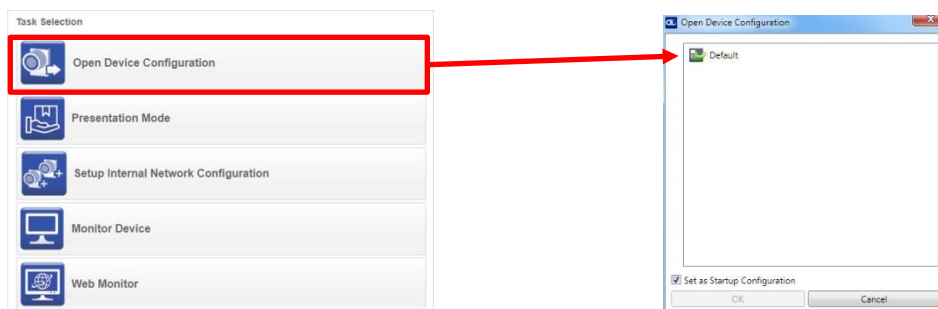
1. From the Task Area select Open Device Configuration.
2. The Open Device Configuration window opens showing the list of currently saved configurations (jobs) saved on the device. For new devices, the only saved job is the Default configuration. Click OK. The device enters run mode and begins acquiring images.



3. Click on the Advanced Setup button and press the Play icon .
4. Place the **Grade A Barcode Test Chart** in the reading area. Once positioned, stop image acquisition by clicking on the Pause button .

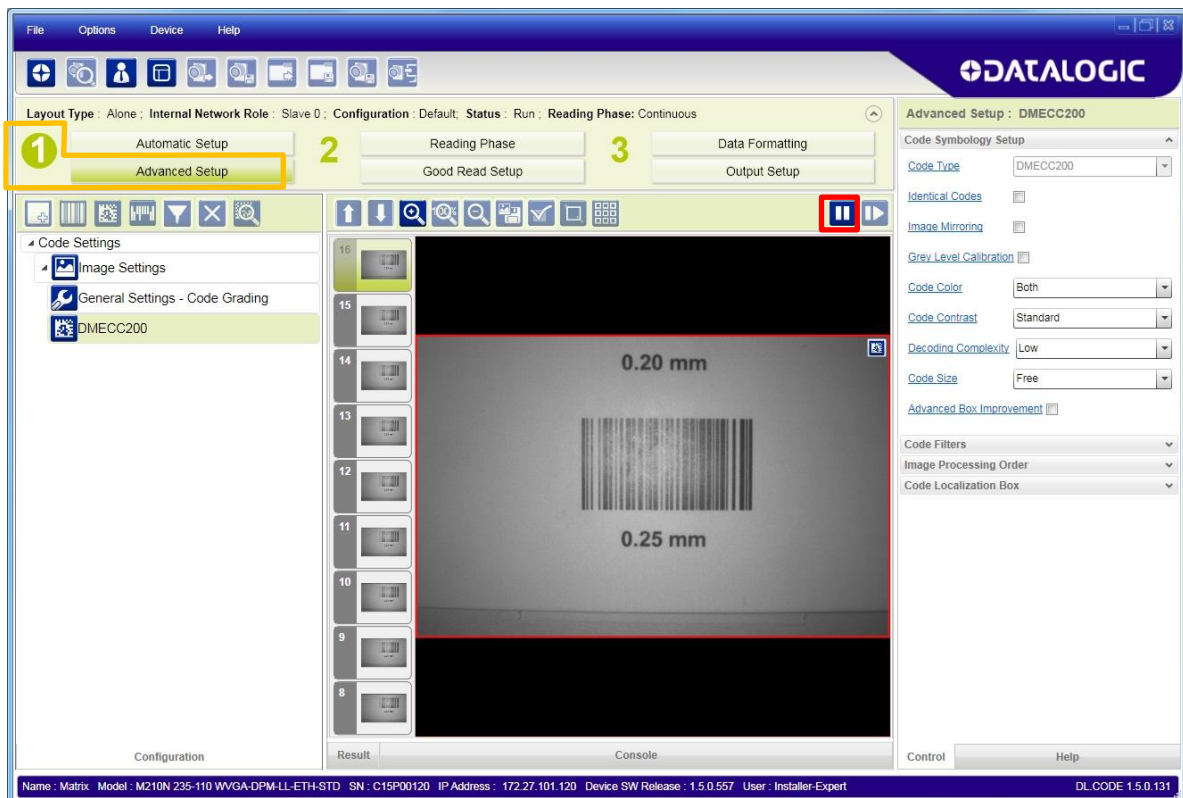

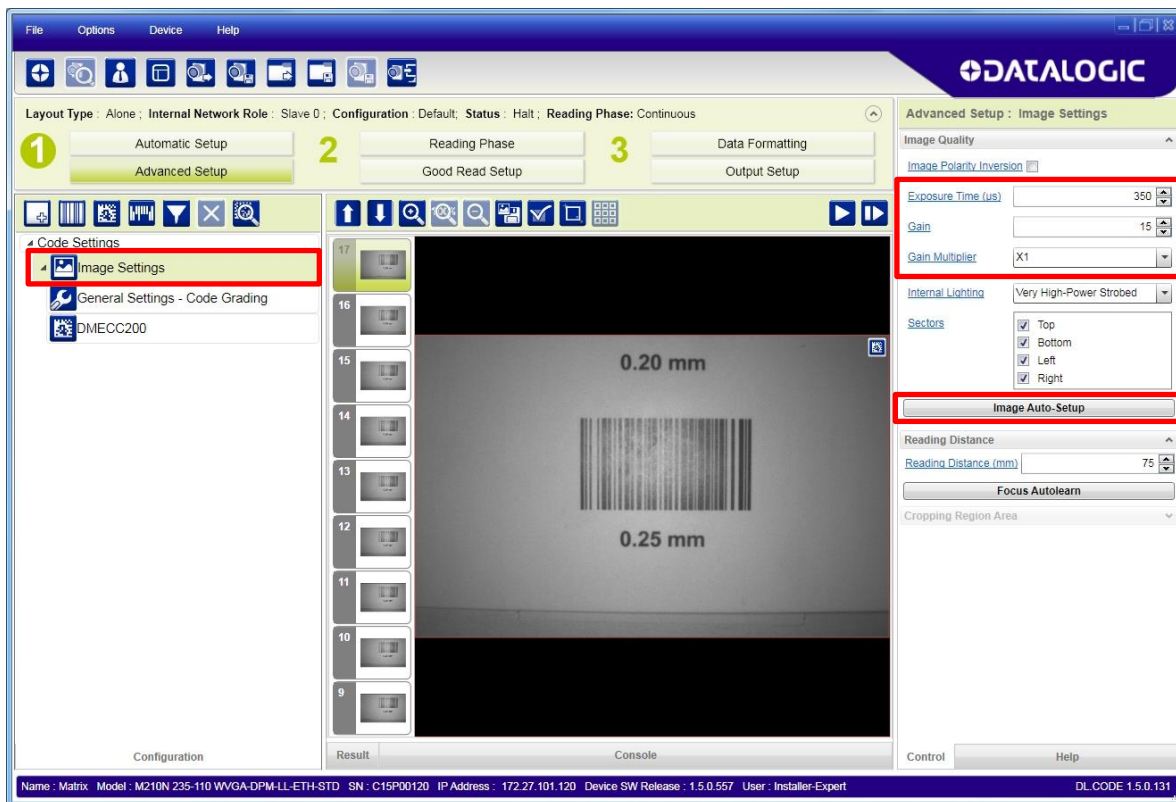

- Click the Image Settings branch and then click the Image Auto Setup button to automatically acquire the best exposure time and gain values.

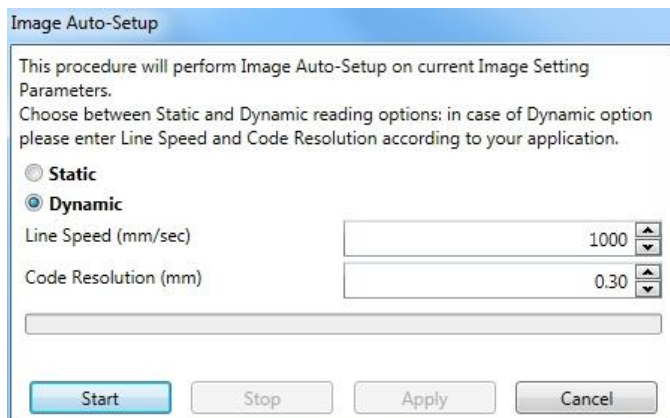

- Select the Static or Dynamic Self-Tuning option; Start Autolearn and Apply to the Image Settings.

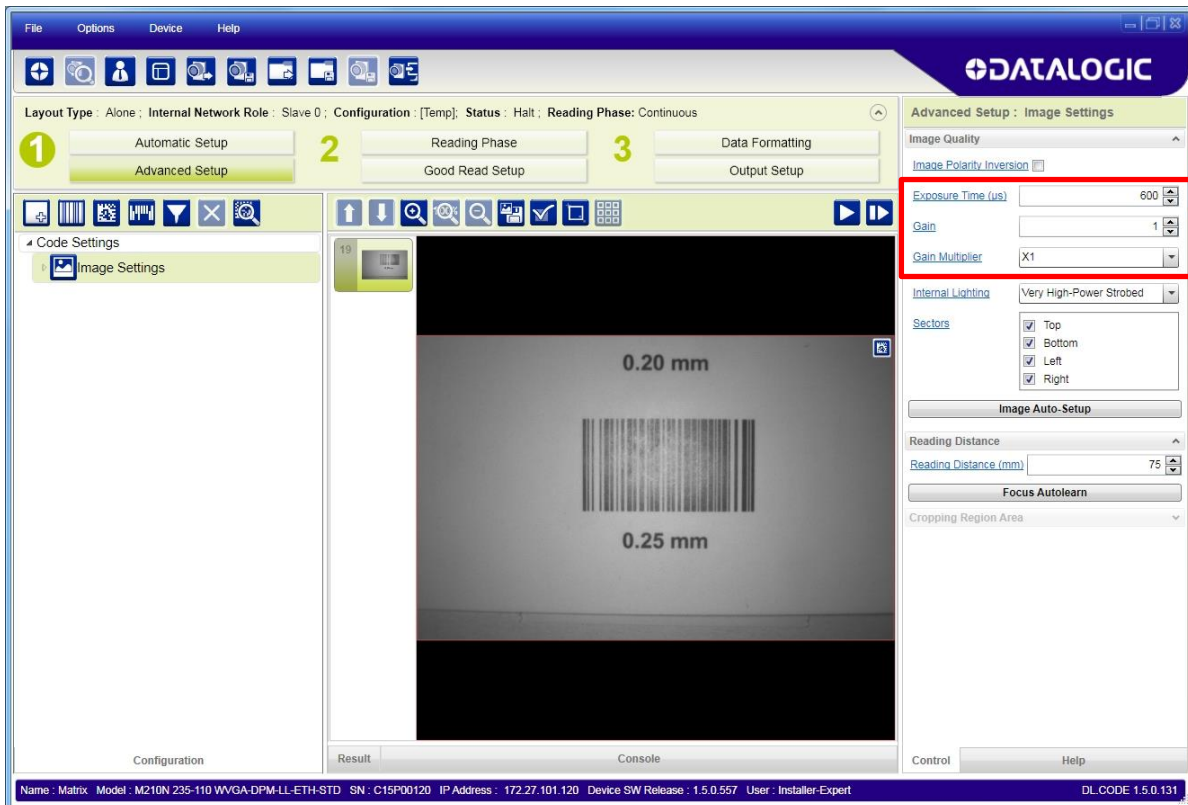



**NOTE:** For applications having multiple lighting or code reading conditions, up to 10 different Image Settings can be configured by adding them with the  icon.

7. Now click on the Focus Autolearn button.

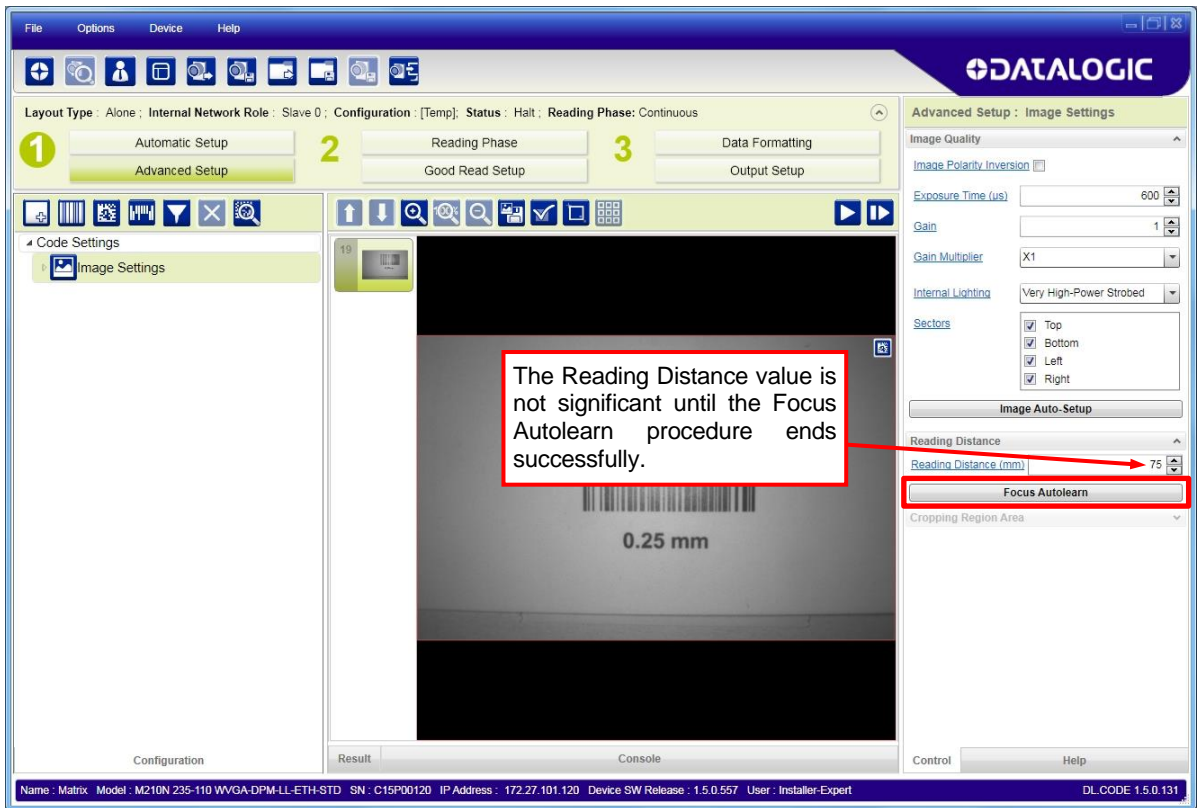

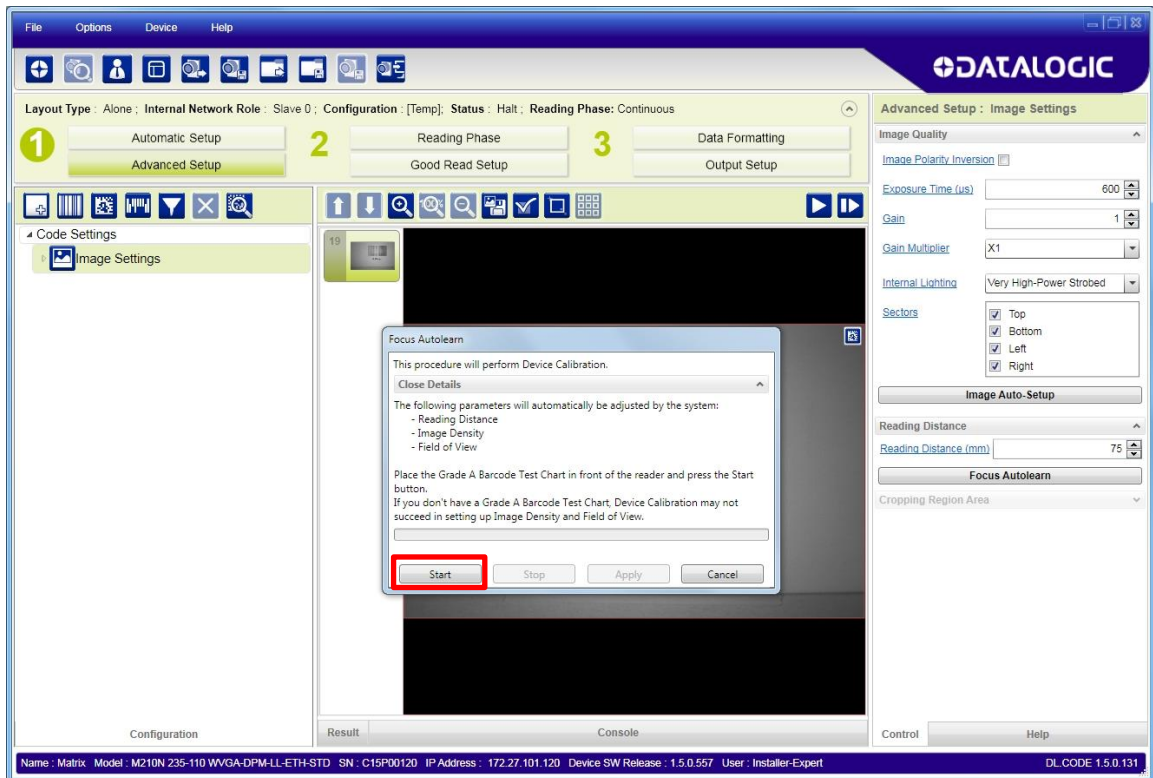

8. The Calibrate dialog box opens allowing you to start the procedure. Click Start.

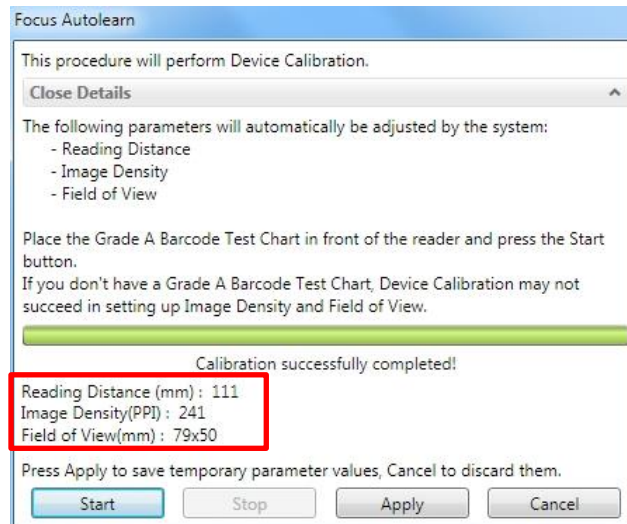

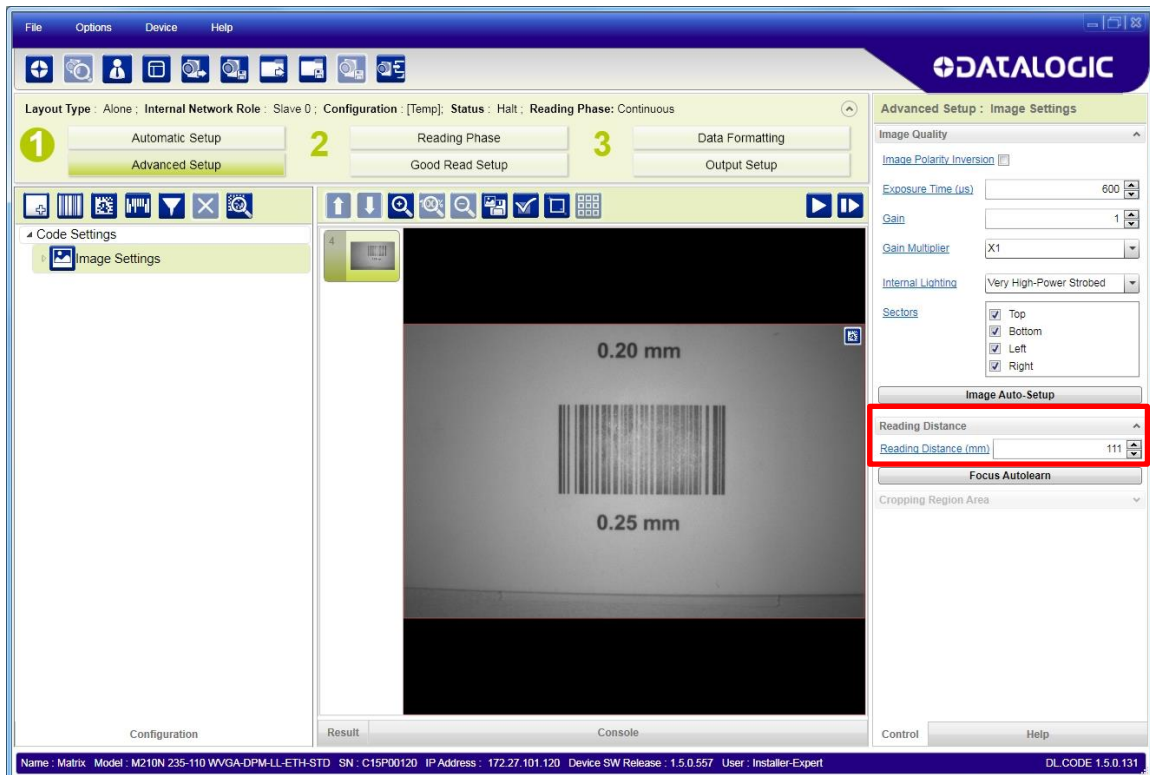

At the end of the calibration you can see the new Reading Distance and Image Density (PPI) values as well as the FOV dimensions. Click Apply.



**NOTE:** To enlarge the visual image of the code view, you can click on the zoom image icon  repositioning it on the code.





**NOTE:** At this point it is probably a good idea to save the configuration from temporary memory to permanent memory giving it a specific name.

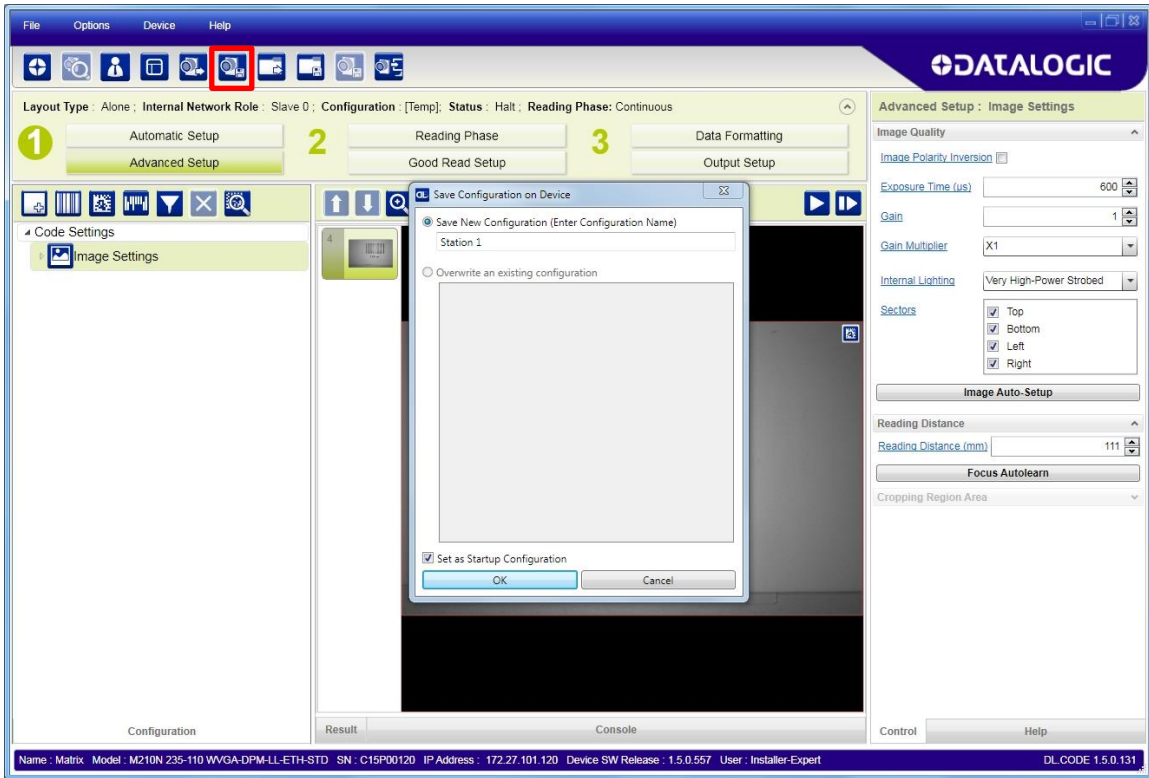

9. Now place an application specific code in front of the reader and repeat only the Image Auto-Setup to register any changes in lighting or code surface contrast.

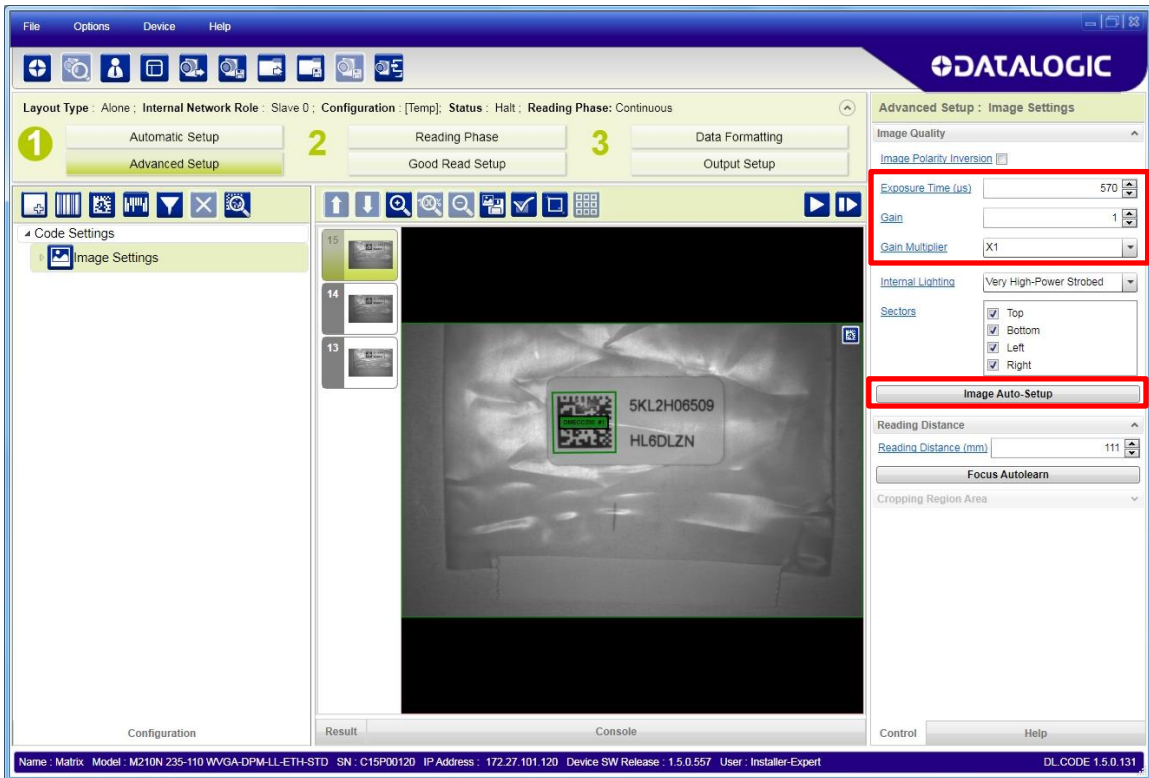

10. Click on the Data Matrix ECC 200 symbology under the Image Settings branch (enabled by default). If this symbology is among those in your application it will be shown in the image display with its code symbology name and a small green box around it indicating it is decoded.

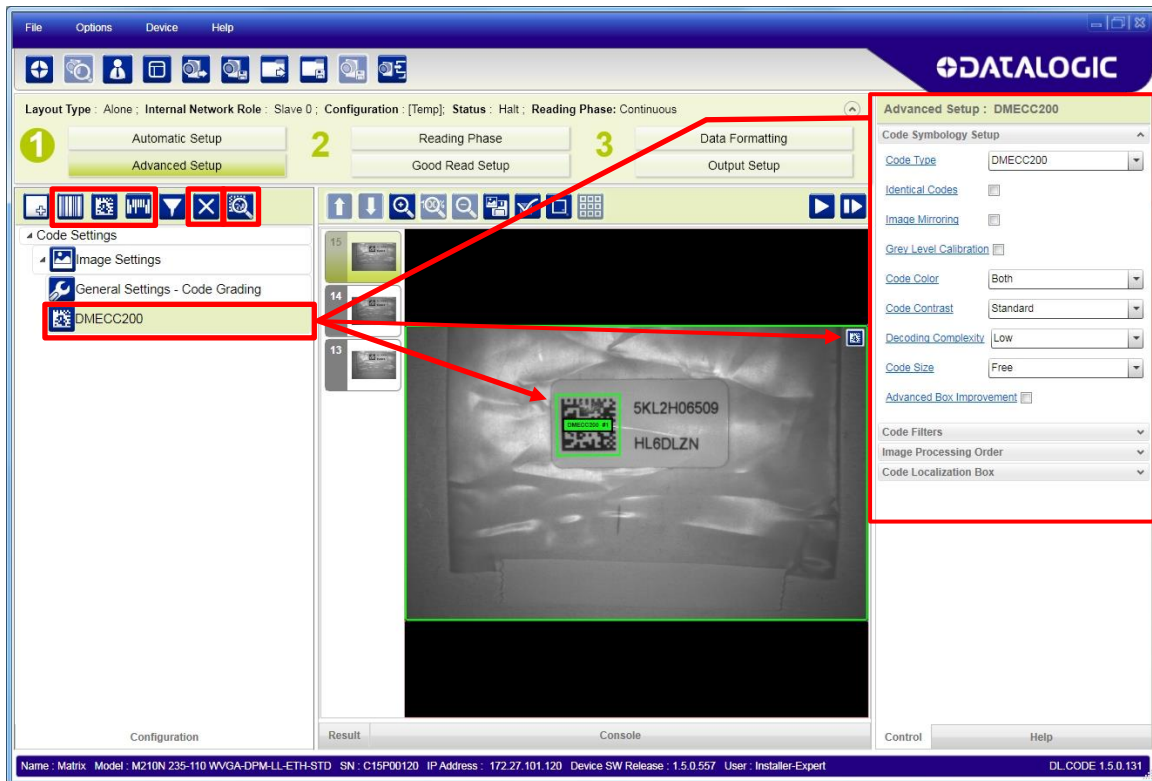

**NOTE:** The large green box for each symbol indicates the code localization area which by default is equal to the maximum FoV. It can be resized and moved by dragging its borders with the mouse. The code must be found within this area in order to be decoded.

11. Add your application specific codes to the Code Settings by selecting them from the icons over the Configuration Parameters tree area. If the Data Matrix symbology is not used, then delete it from the Code Settings with the icon.

If you don't know the code type, you can use the Code Autolearn feature by clicking on the icon.<sup>3</sup> See the DL.CODE User's Manual for details.

12. For each code symbology set the relative parameters according to your application.



**NOTE:** Continue the configuration on page 35 (**Reading Phase**).

<sup>3</sup> The Code Autolearn procedure will not recognize the following symbologies: Pharmacode, MSI, Standard 2 of 5, Matrix 2 of 5.

## Advanced Setup for Fixed Focus Models



**NOTE:** For Software Adjustable Focus models go to page 24 then continue the configuration on page 35. (**Reading Phase**).

To begin configuration, the reader must be correctly mounted at the correct reading distance for your application so that its Field of View covers the application reading area.

1. From the Task Area select Open Device Configuration.
2. The Open Device Configuration window opens showing the list of currently saved configurations (jobs) saved on the device. For new devices, the only saved job is the Default configuration. Click OK. The device enters run mode and begins acquiring images.

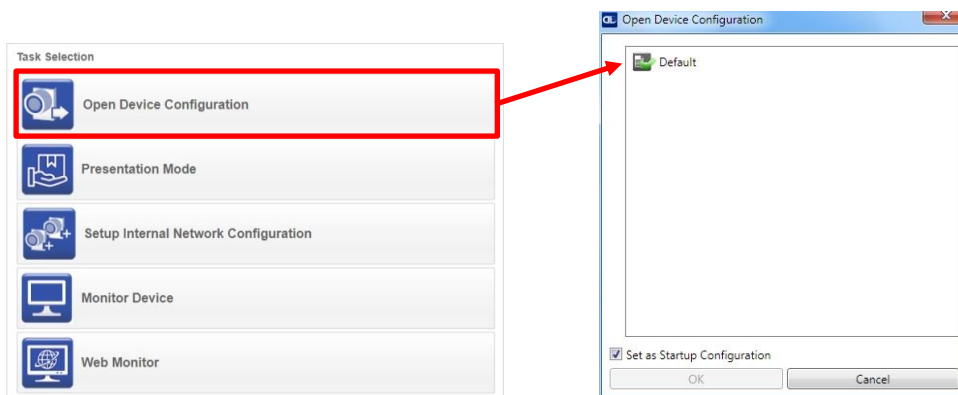

3. Click on the Advanced Setup button and press the Play icon .

- Place an **application specific code** in the reading area. Once positioned, stop image acquisition by clicking on the Pause button. If a Data Matrix code is placed in front of the reader you may also see the green good decoding box imposed on the display image.

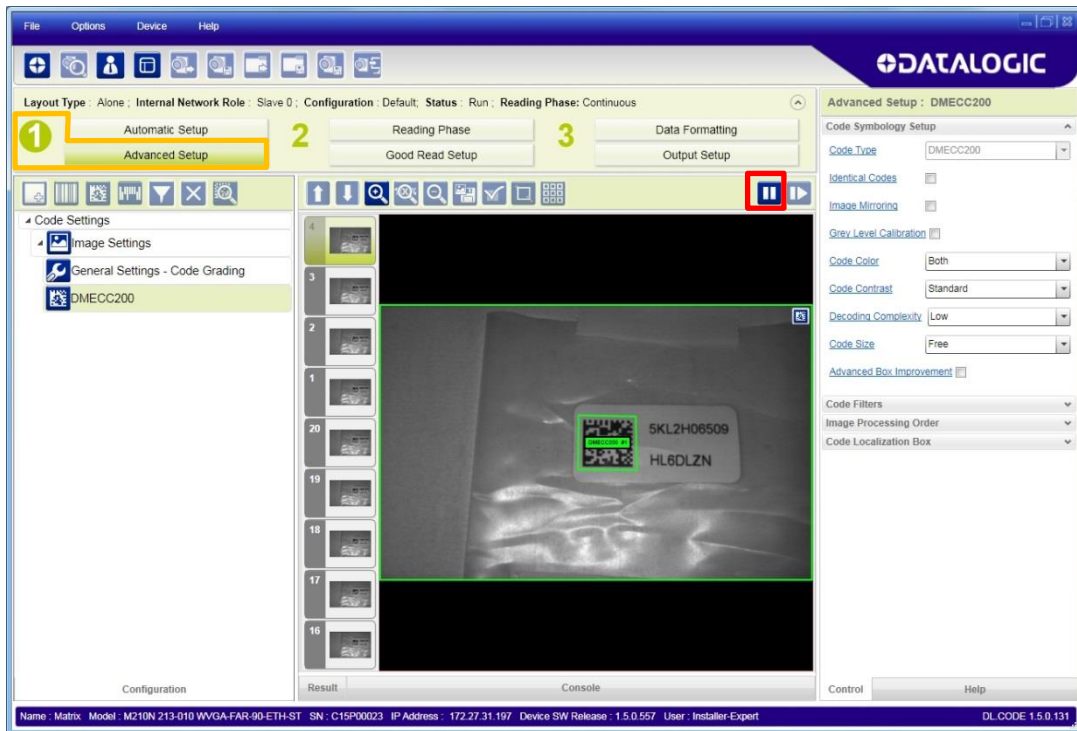

- Click the Image Settings branch and then click the Image Auto Setup button to automatically acquire the best exposure time and gain values.

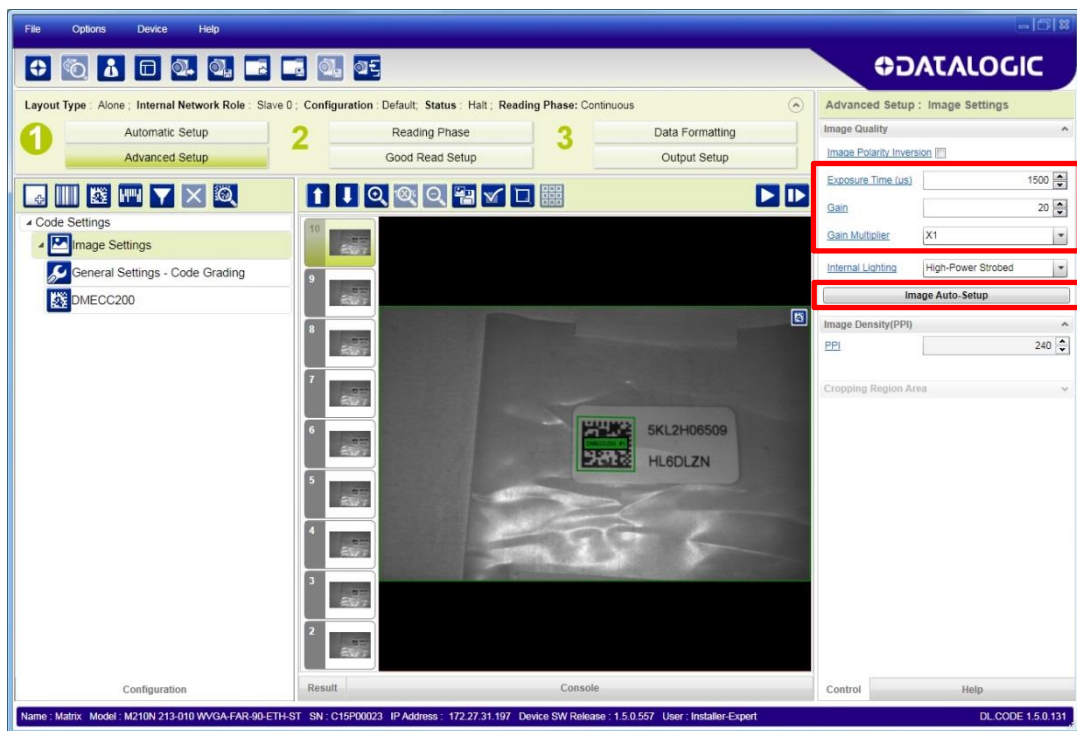

6. Select the Static or Dynamic Self-Tuning option; Start the Image Auto-Setup and Apply to the Image Settings.

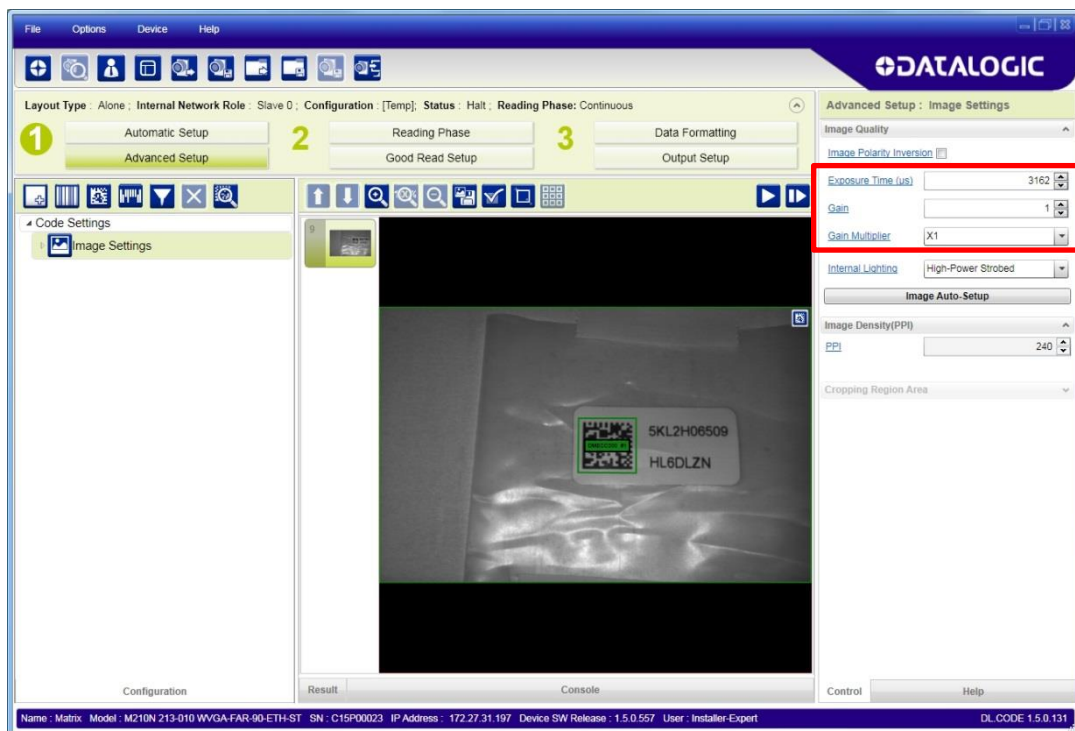
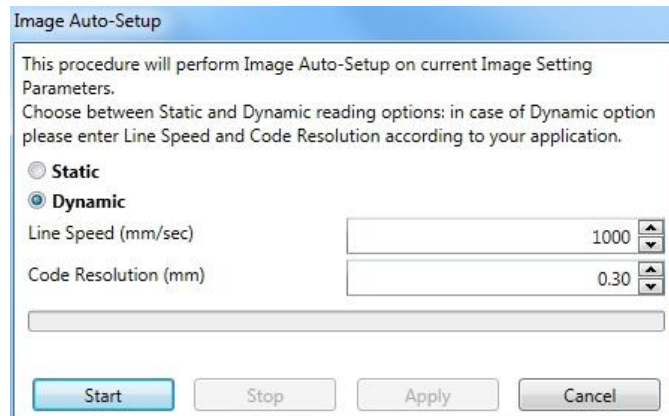

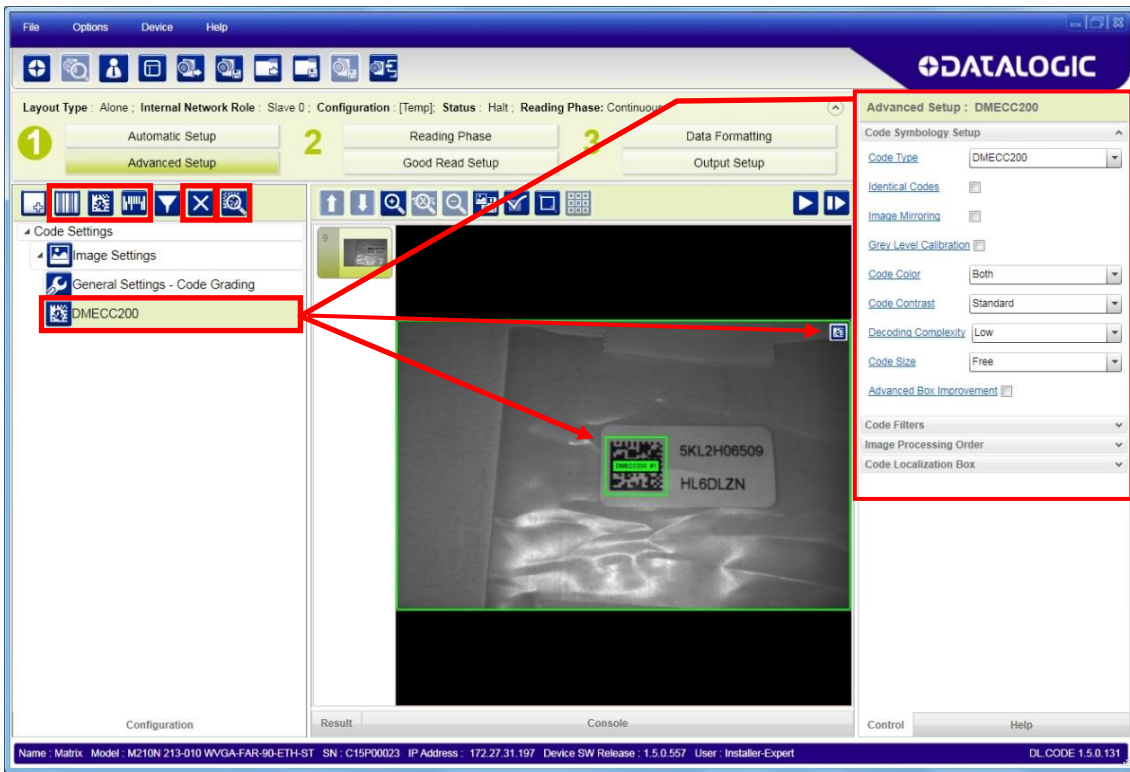

**NOTE:** For applications having multiple lighting or code reading conditions, up to 10 different Image Setups can be configured by adding them with the  icon.

7. Click on the Data Matrix ECC 200 symbology under the Image Settings branch (enabled by default). If this symbology is among those in your application it will be shown in the image display with its code symbology name and a small green box around it indicating it is decoded.



**NOTE:** The large green box for each symbol indicates the code localization area which by default is equal to the maximum FoV. It can be resized and moved by dragging its borders with the mouse. The code must be found within this area in order to be decoded.

8. Add your application specific codes to the Code Settings by selecting them from the icons over the Configuration Parameters tree area. If the Data Matrix symbology is not used, then delete it from the Code Settings with the  icon.

If you don't know the code type, you can use the Code Autolearn feature by clicking on the  icon.<sup>4</sup> See the DL.CODE User's Manual for details.

9. For each code symbology set the relative parameters according to your application.

<sup>4</sup> The Code Autolearn procedure will not recognize the following symbologies: Pharmacode, MSI, Standard 2 of 5, Matrix 2 of 5.

## Reading Phase

1. Select your application specific Operating Mode from the icons over the Configuration Parameters tree area: Continuous, One Shot, or Phase Mode.

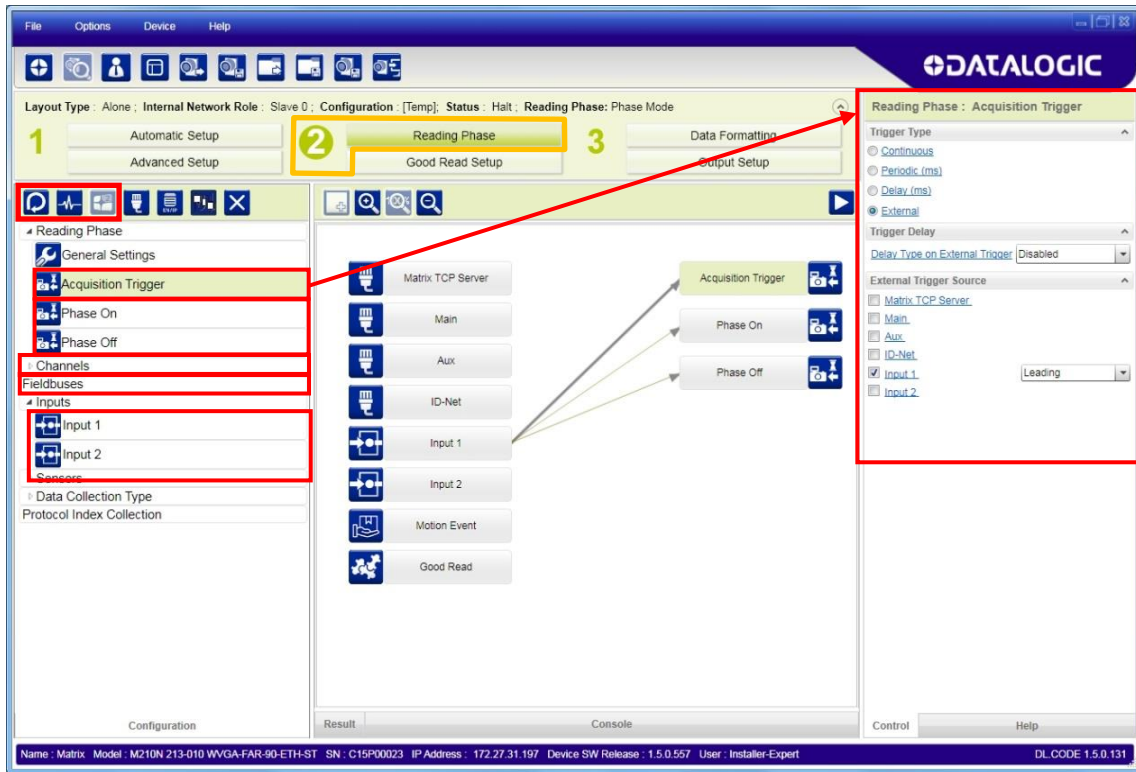

2. Configure the relative Operating Mode parameters from the Reading Phase parameters panel. Different groups will appear in the panel depending on the selected icons over the Configuration Parameters tree area.

## Good Read Setup

1. Select your specific data collection type from the icons over the Configuration Parameters tree area: Code Collection, Code Combination, Presentation or Match Code. Not all data collection types are available for all Operating Modes. Incompatible data collection types will be shown in grey and cannot be selected.

The following example shows Code Combination. By default, the Expected Codes (when more than one code type is selected), are in logical AND, which means that all codes are required to be decoded to produce a Good Read condition.

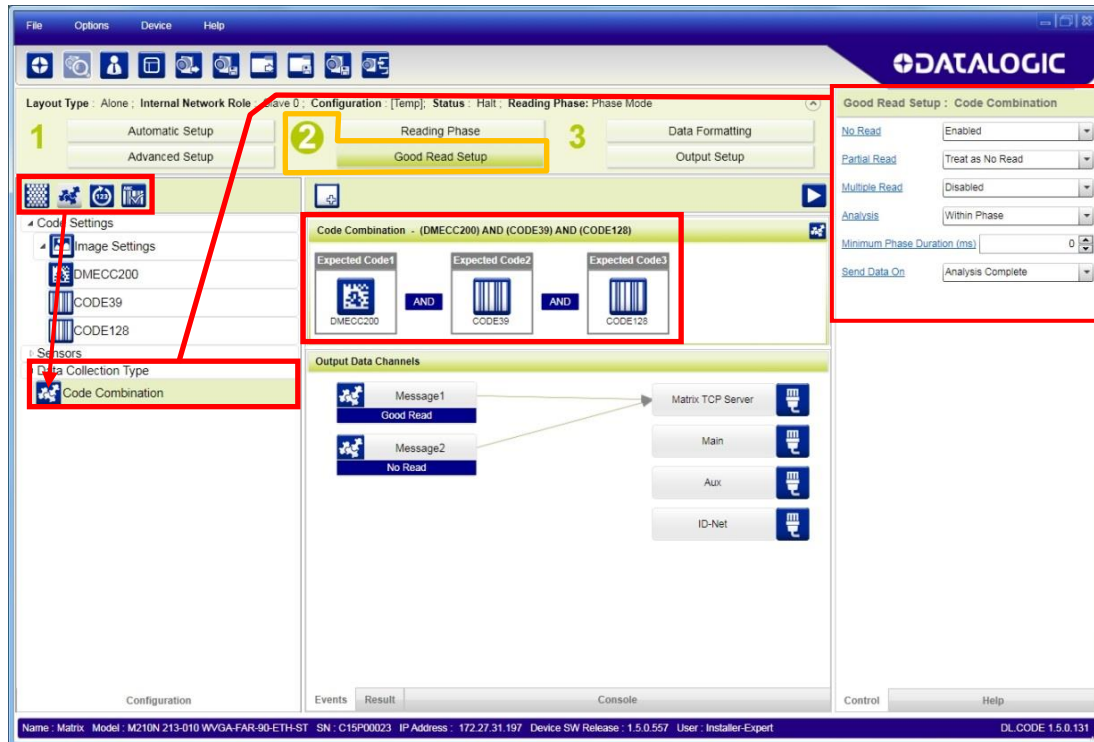

2. If a Good Read condition should be produced when any single code is decoded, independent from the others, then they need to be combined in logical XOR. To do this, drag the code icon(s) from their relative Expected Code box into the Expected Code box of the XOR combination you wish to create. Then delete the empty box by selecting it with the mouse (highlighted) and pressing the delete key on your keyboard.

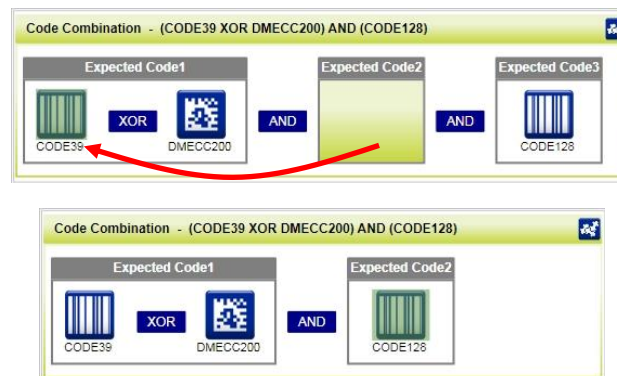



To create a logical AND condition from a logical XOR, create a new Expected Code box using the  icon. Then drag the desired code icon from one box to the other.



## Data Formatting

1. Configure your application specific Data Formatting Message(s) from the Configuration Parameters tree area: Message 1, Message 2, etc.

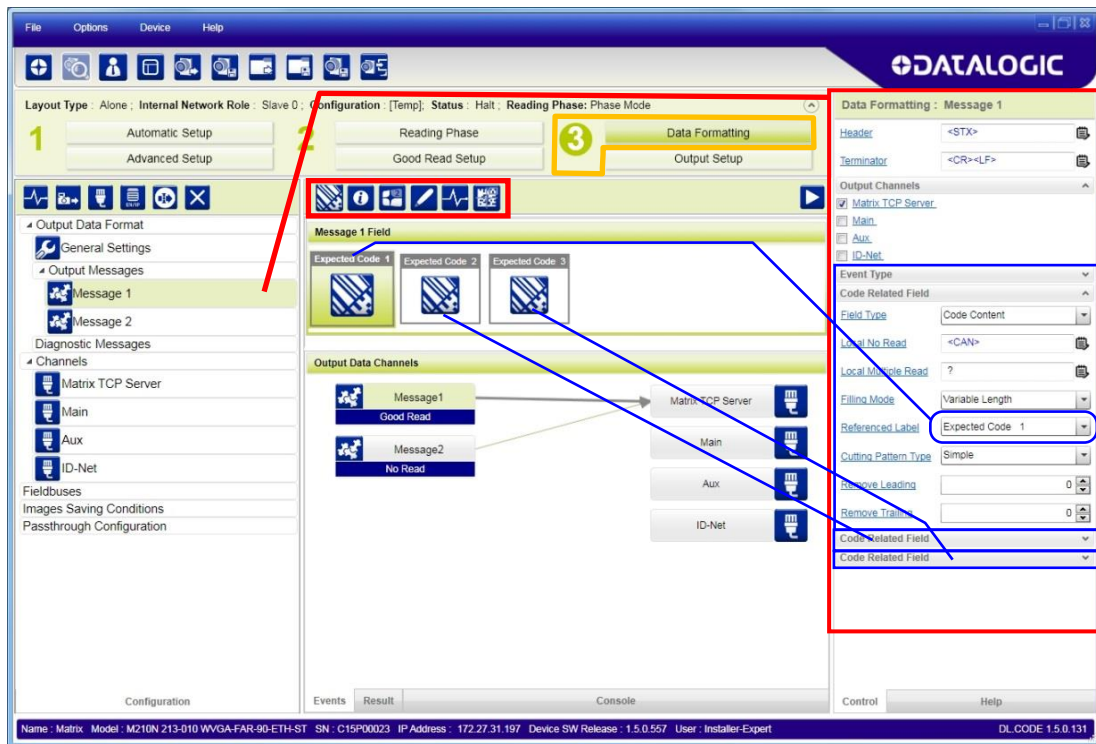

You can add fields to the output message by clicking on the icons above the Message Field area. They will be appended to the message. You can drag them to position them between other fields in the message so that the output message is ordered according to your application requirements.

Each field has its own relative configuration parameters in the parameters panel.

## Output Setup

1. Configure your application specific Digital Output(s) and Green/Red Spots (if used) from the Configuration Parameters tree area: Output 1, Output 2, etc.

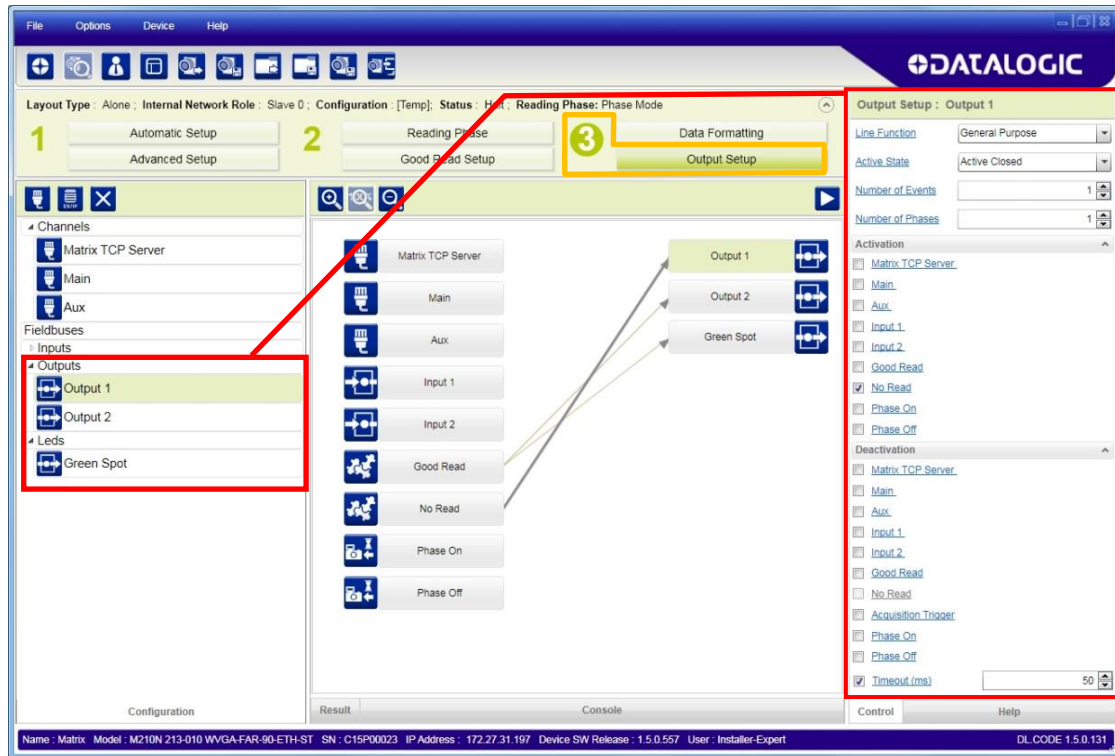

**NOTE:** Save the configuration from temporary memory to permanent memory, overwriting the previously saved configuration.

### STEP 7 – TEST MODE

Use a code suitable to your application to test the reading performance of the system. Alternatively, you can use the Datalogic 1D/2D Test Chart (Code 39, Data Matrix ECC 200).

1. Enter the *Test* function by pressing and holding the X-PRESS push button until the Test LED is on.
2. Release the button to enter the *Test* function.

Once entered, the Bar Graph on the five LEDs is activated and if the reader starts reading codes the Bar-Graph shows the Good Read Rate.



Figure 17 – X-PRESS Interface: Test Function

3. To exit the Test, press the X-PRESS push button once.



**NOTE:** By default, the Test exits automatically after three minutes.

The Bar Graph has the following meaning:

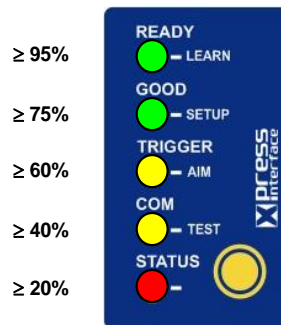

Figure 18 – Test Bar Graph

In case of No Read condition, only the STATUS LED is on and blinks.

## **ADVANCED READER CONFIGURATION**

For further details on advanced product configuration, refer to the DL.CODE User's Manual available in the DL.CODE Help menu.

### **Host Mode Programming**

The reader can also be partially configured from a host computer using the Host Mode programming procedure.

## 2 INTRODUCTION

---

### 2.1 PRODUCT DESCRIPTION

Matrix 210N is the new Datalogic 2D reader offering excellent reading performance, ultra compact size and extreme ease of use. Thanks to innovative optical features, advanced software functions and complete connectivity options, Matrix 210N is the cost effective solution for applications where the space is very limited.

#### **Ultra Compact Size**

Compact dimensions allow flexible mounting and positioning in narrow spaces.

#### **Excellent Reading Performance**

WVGA image sensor, up to 60 frames/s acquisition rate and dynamic reading capability, together with powerful decoding libraries provide excellent performance on a wide range of code symbologies as well as damaged and low quality codes. Matrix 210N allows reading 10 mils codes in moving applications at speeds up to 2 m/sec.

#### **Innovative Optical Features**

The Liquid Lens technology allows dynamic focusing to extend Depth of Field. The innovative optical and lighting systems ensure wide field of view at short reading distances, combined with excellent illumination pattern.

#### **Ease Of Use**

The intuitive X-PRESS Human Machine Interface makes installation and maintenance easier than ever thanks to a five LED bar graph and the multi-function key providing immediate access to relevant functions such as Aiming, Setup (for automatic imager calibration), Learn (for automatic code setting), Test Mode (for bar graph activation). A Green Spot provides immediate Good Read feedback.

#### **Enhanced Connectivity**

An embedded Ethernet interface allows for faster communication

An embedded high speed ID-NET communication interface allows efficient data collection and simplifies network wiring.

#### **Industrial Features**

Matrix 210N, with its rugged construction, IP65 protection class and 10 to 30 VDC power supply is the ideal product for industrial applications.

Matrix 210N has been developed for use in numerous industries like:

Electronics:

- PCB Board Tracking
- Electronics Product Tracking

Pharmaceutical & Chemical:

- Medical Devices Traceability
- Pharmaceutical and Medicine Manufacturing

OEM:

- Chemical & Biomedical Analysis Machines
- Access Control Systems
- Self Service Systems (ATM, Kiosks)
- Print & Apply systems
- Document Handling

This technology intrinsically provides omni-directional reading.

### **Standard Application Program**

A Standard Application Program is factory-loaded onto Matrix 210N. This program controls code reading, data formatting, Ethernet interfacing, serial port and USB interfacing, and many other operating and control parameters. It is completely user configurable from a Laptop or PC using the dedicated configuration software program DL.CODE, provided on the DL.CODE mini-DVD (downloaded .zip file or mini-DVD accessory).

There are different programmable operating modes to suit various code reading system requirements.

Quick, automatic positioning, calibration and code setting of the imager can be accomplished using the X-PRESS button and LEDs on top of the reader without the necessity of a PC.

The previous functions can also be performed through DL.CODE. This tool includes visual feedback from the reader.

DL.CODE allows verifying the exact positioning of the reader to maximize its reading performance.

Statistics on the reading performance can also be visualized through a dedicated window in DL.CODE.

### **Programmability**

If your requirements are not met by the Standard Application Program, Custom Application Programs can be requested at your local Datalogic distributor.

Some of the main features of this reader are given below:

- Ultra Compact Dimensions
- Outstanding decoding capability on 1D, 2D, Stacked and Postal symbologies
- High performance on dynamic reading applications
- X-PRESS for easy and intuitive setup
- Optical Aiming System
- 10 to 30 VDC Power Supply
- High Speed on-board Ethernet Connectivity
- ID-NET embedded high speed network connectivity
- Image Cropping for higher frame rate

## 2.2 INDICATORS AND KEYPAD BUTTON

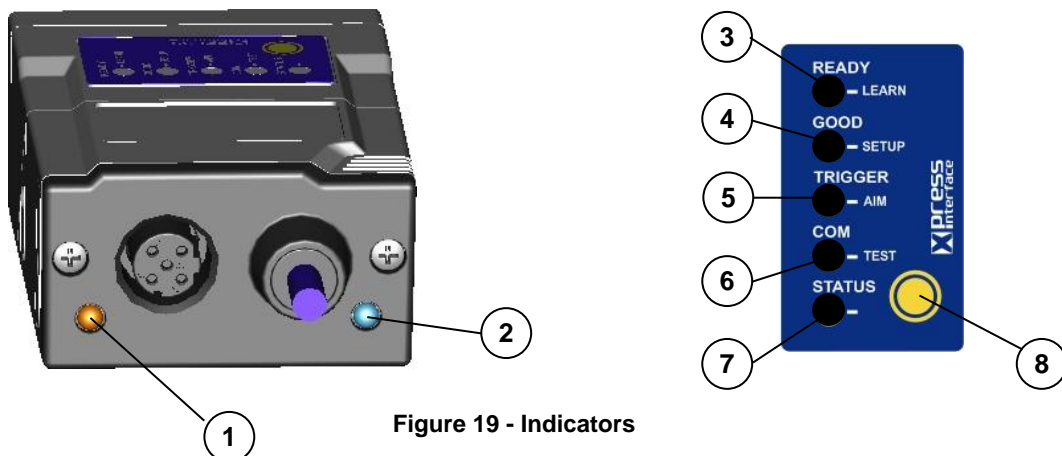

Figure 19 - Indicators

The following LED indicators are located on the reader:

<b>NET</b>	On the connector side of the reader near the Ethernet connector, the orange ETHERNET NETWORK PRESENCE LED indicates the on-board Ethernet network connection. (Figure 19, 1)
<b>PWR</b>	On the connector side of the reader near the cable, the blue POWER ON LED indicates the reader is correctly powered. (Figure 19, 2)

In normal operating mode the colors and meaning of the five LEDs are illustrated in the following table:

<b>READY</b>	green LED indicates that the reader is ready to operate (Figure 19, 3)
<b>GOOD</b>	green LED confirms successful reading (Figure 19, 4)
<b>TRIGGER</b>	yellow LED indicates the status of the reading phase (Figure 19, 5)
<b>COM</b>	yellow LED indicates active communication on the main serial port * (Figure 19, 6)
<b>STATUS</b>	red LED indicates a NO READ result (Figure 19, 7)

\* When connected to a Fieldbus network through the CBX500, the COM LED is always active, even in the absence of data transmission, because of polling activity on the Fieldbus network.

During the reader startup (reset or restart phase), these five LEDs blink for one second.

In X-PRESS Configuration mode the colors and meaning of these five LEDs are described in par. 2.4.

The keypad button (Figure 19, 8, is software programmable. By default it starts the X-PRESS interface for quick installation without using a PC (see chp. 1).



## 2.3 ID-NET

The ID-NET network is a built-in high-speed interface dedicated for high-speed reader interconnection. ID-NET is in addition to the Main and Auxiliary serial interfaces.



The following network configurations are available:

- **ID-NET Synchronized:** Single station – multiple readers

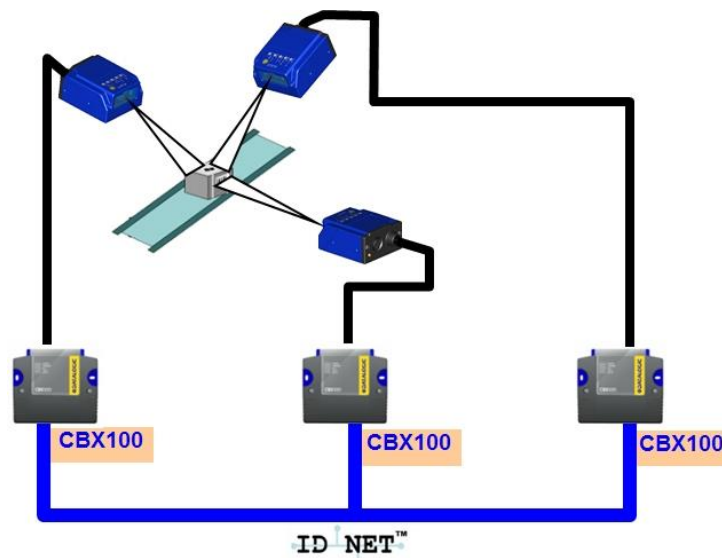

ID-NET interface allows local connection of multiple readers reading different sides of the same target. All readers share a single presence sensor and activate/deactivate simultaneously.

At the end of each reading phase a single data message is transmitted to the host.

Thanks to ID-NET, data communication among readers is highly efficient so that an immediate result will be available.

See par. 4.3 for connection details and par. 7.4 for configuration details.

- **ID-NET™ Multidata:** Multiple stations – single reader

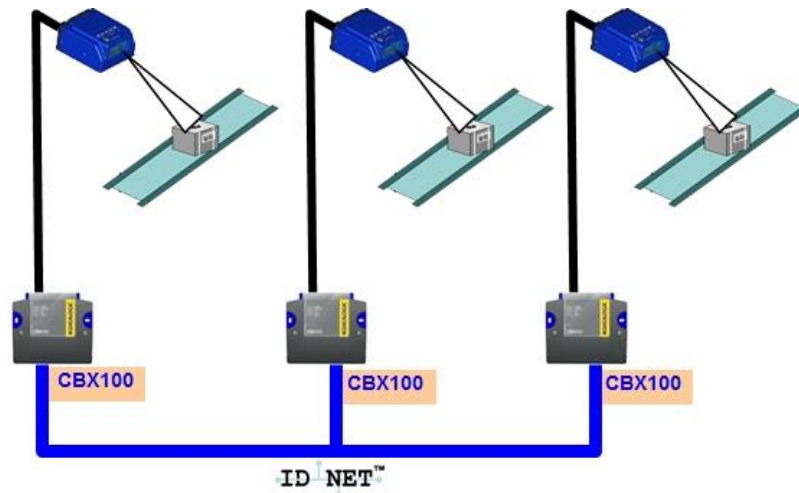

ID-NET interface allows connection of readers reading objects placed on independent conveyors. All readers are typically located far away from each other and they can have different operating modes from each other.

At the end of each reading phase, each reader transmits its own data message to the host. Thanks to ID-NET, data collection among readers is accomplished at a high speed without the need of an external multiplexing device. This leads to an overall cost reduction and to simple system wiring.

See par. 4.3 for connection details and par. 7.4 for configuration details.

## 2.4 X-PRESS HUMAN MACHINE INTERFACE

X-PRESS is the intuitive Human Machine Interface designed to improve ease of installation and maintenance.

Status information is clearly presented by means of the five colored LEDs, whereas the single push button gives immediate access to the following relevant functions:

- Learn to self-detect and auto-configure for reading unknown codes.
- Setup to perform Exposure Time and Gain calibration.
- Aim/Locate to turn on the blue ring to aid positioning.
- Test with bar graph visualization to check static reading performance.



### 2.4.1 X-PRESS Functions

Quick access to the following functions is provided by an easy procedure using the push button:

- 1 – **Press** the button (the Status LED will give a visual feedback).
- 2 – **Hold** the button until the specific function LED is on (Test, Focus, Setup or Learn).
- 3 – **Release** the button to enter the specific function.

Once button is pressed, the cycle of LEDs activation is as follows:

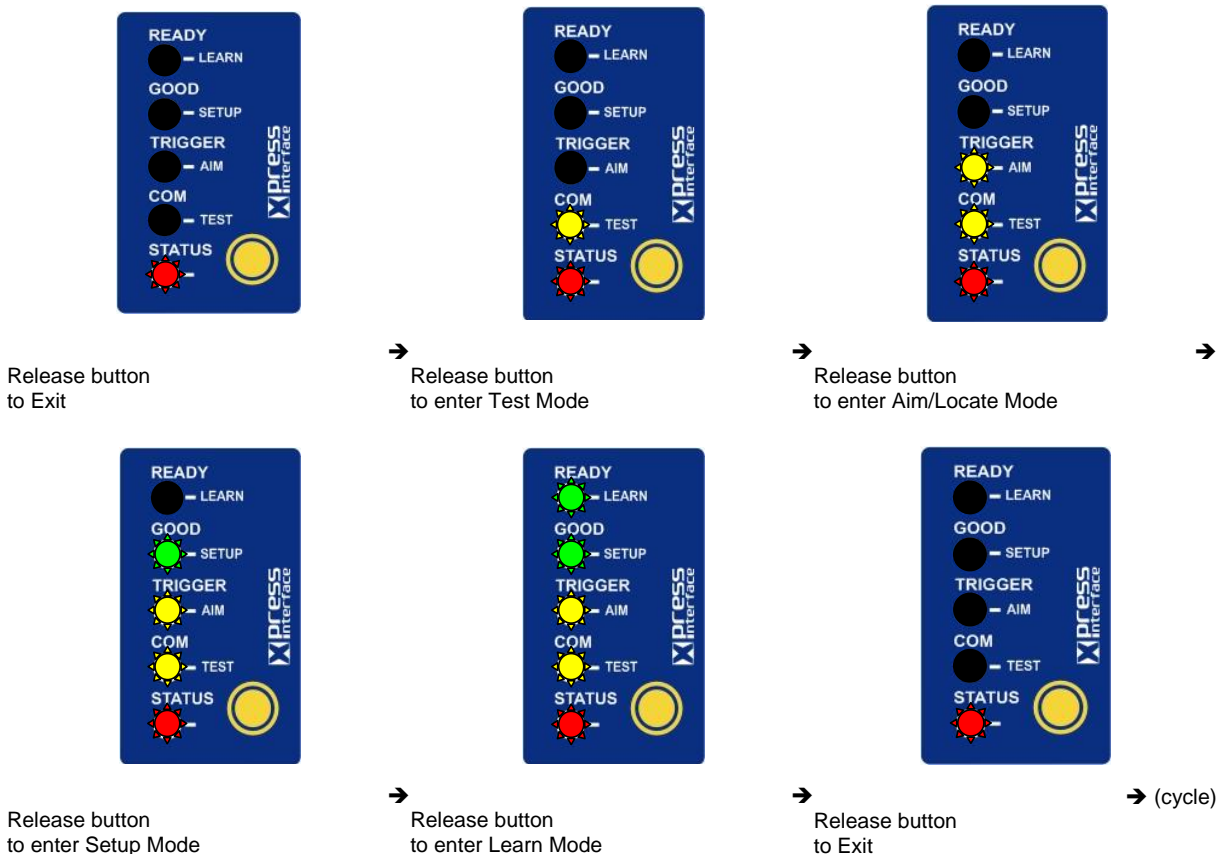

## Test Mode

Once entered, the Bar Graph on the five LEDs is activated and if the imager starts reading codes the Bar-Graph shows the Good Read Rate. The Bar Graph has the following meaning:

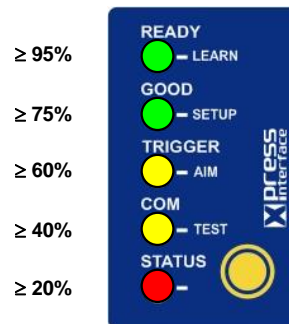

In case of a NO READ condition, only the Status LED is on and blinks.

To exit the Test Mode, press the X-PRESS push button once.



**NOTE:** By default, the Test exits automatically after three minutes.

## Aim/Autofocus

This function causes the laser pointers to turn on. Since the laser pointers are centered on the FOV they can be used to position the imager on the code. The Aim LED blinks to indicate this state. After a short delay, this function also performs the Autofocus procedure for Liquid Lens models.

You can exit the Aim/Autofocus function at any time by pressing the X-PRESS push button once. After a short delay the autofocus procedure is cancelled and the laser pointers turn off.

## Setup

Once entered, the imager automatically performs Image Acquisition parameter calibration (photometry) for the specific code presented to it.

The Setup LED will blink until the procedure is completed.

The Setup procedure ends when the Image Acquisition parameters are successfully saved in the reader memory, the Setup LED will stop blinking and Matrix 210N emits 3 high pitched beeps.

If the calibration cannot be reached after a timeout of about 5 (five) seconds Matrix 210N will exit without saving the parameters to memory, the Setup LED will stop blinking and in this case Matrix 210N emits a long low pitched beep.

## Learn

Once entered, the imager starts a procedure to automatically detect and recognize a **single code** which is presented to it. Successive Learns will substitute the current code.

The Learn LED will blink until the procedure is completed.

The Learn procedure ends when the Image Processing and Decoding parameters are successfully saved in the reader memory, the Learn LED will stop blinking and Matrix 210N emits 3 high pitched beeps.

If the autolearning cannot be reached after a timeout of about 3 (three) minutes, Matrix 210N will exit without saving the parameters to memory, the Learn LED will stop blinking and in this case Matrix 210N emits a long low pitched beep.

You can exit the Learn function at any time by pressing the X-PRESS push button once. After a short delay the Learn procedure is cancelled.

### 2.4.2 Diagnostic Indication

The "STATUS" and "READY" LEDs blink simultaneously to signal the presence of an error. Diagnostic message transmission on interfaces can be enabled to provide details about specific error conditions. See the Diagnostic Error Conditions chart in the Diagnostic page of the DL.CODE Monitor.



LED	STATUS
READY	BLINK
GOOD	
TRIGGER	
COM	
STATUS	BLINK

## 2.5 MODEL DESCRIPTION

Matrix 210N readers are described by their model number which indicates the characteristics listed in the diagram below. Not all combinations are available. For a complete list of combinations see the Models tab on the Product page of the website.

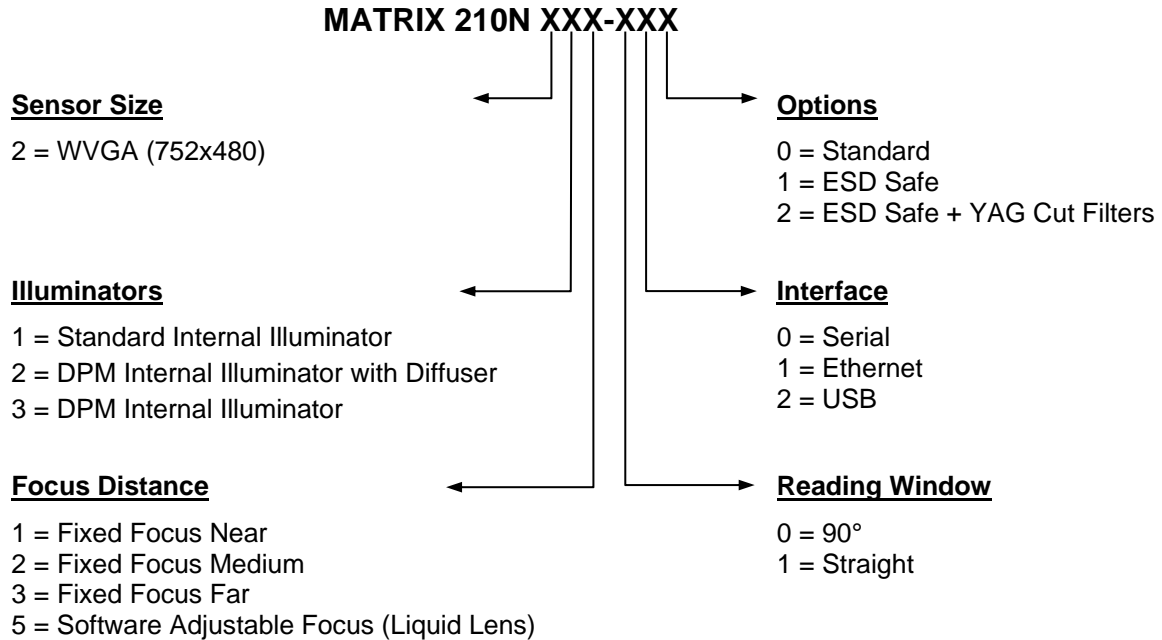

## 2.6 ACCESSORIES

The following accessories can be used with the Matrix 210N readers.

Accessory	Description	Order No.
<b>External Illuminator</b>		
LT-700	Linear Array Lighting System	93A401028
BK-21-000	LT-700 Fixing Bracket	93ACC0052
<b>Cables</b>		
CAB-ETH-M01	M12-IP67 Ethernet Cable (1M)	93A051346
CAB-ETH-M03	M12-IP67 Ethernet Cable (3M)	93A051347
CAB-ETH-M05	M12-IP67 Ethernet Cable (5M)	93A051348
CBL-1534.02	Adapter Cable Ethernet M12 to RJ45	93A050057
CBL-1480-01	Thin M12/5P Male/Female (1M)	93A050049
CBL-1480-02	Thin M12/5P Male/Female (2M)	93A050050
CBL-1490	Term. Resist. Thin M12/5P/Male	93A050046
CBL-1496	Term. Resist. Thin M12/5P/Female	93A050047
<b>Connectivity</b>		
CBX100	Compact Connection Box	93A301067
CBX500	Modular Connection Box	93A301068
BM100	Backup Module for CBX100/500	93ACC1808
BM150	Display Module for CBX500	93ACC1809
Various Fieldbus Host Interface Modules and All-In-One Connection Box Kits are available		
BA100	DIN Rail Adapters	93ACC1821
BA200	Bosch and 80/20 Profile Adapters	93ACC1822
Various M12 Panel Connectors for CBX Connection Boxes are available		
QL100	Quick Link Slave ID-NET T-Connector	93ACC1860
QL150	Quick Link Slave ID-NET + Service T-Connector	93ACC1868
QL300	Quick Link Master ID-NET - Serial Host Connector	93ACC1862
QLM500	Quick Link Metal Master ID-NET - EtherNet/IP Gateway	93ACC0037
QLM600	Quick Link Metal Master ID-NET - Profibus Gateway	93ACC0033
QLM700	Quick Link Metal Master ID-NET - Profinet IO Gateway	93ACC0038
Various M12 Service Cables and Field Mount Connectors are available for Quick Link Series Connectors		
<b>Power Supplies</b>		
PG6002	AC/DC Power Supply Unit (US)	93ACC1718
PG6001	AC/DC Power Supply Unit (UK)	93ACC1719
PG6000	AC/DC Power Supply Unit (EU)	93ACC1720
<b>Sensors</b>		
MEP-593	Photocell Kit PNP (PH-1)	93ACC1791
MEP-543	Photocell Kit-NPN	93ACC1728
<b>Brackets</b>		
BK-21-020	Fixing Bracket Kit for 0 Degree (straight) models	93ACC0199
BK-21-030	Fixing Bracket Kit for 90 Degree models	93ACC0200

## 2.7 APPLICATION EXAMPLES

### 2.7.1 Document Handling

Matrix 210N is profitably used in the omnidirectional reading of 2D, stacked, linear and postal codes for example in automated document handling and mail processing systems (see Figure 20).



Figure 20 - Address Coded in Data Matrix Symbology for Automated Mail Processing

### 2.7.2 Deformed or Overprinted Code Reading

Matrix 210N assures the reading of deformed and / or overprinted codes, even though damaged or printed on high reflective surfaces (see Figures 18, 19, 20).



Figure 21 - Unidose Flow-Pack with PDF417 Code



Figure 22 - Overprinted Barcode Readable by Matrix 210N also Through the Envelope Window Film



Figure 23 - Barcode Printed on Curved Surface Readable by Matrix 210N in spite of Image Optical Distortion



### 2.7.3 Direct Part Marking

Matrix 210N is also very powerful in reading low-contrast direct part marked codes (see Figures 21, 22, 23, 24 and 25).



Figure 24 - Dot Matrix Code Directly Marked on Metal Surface by Using Dot Peening Technology

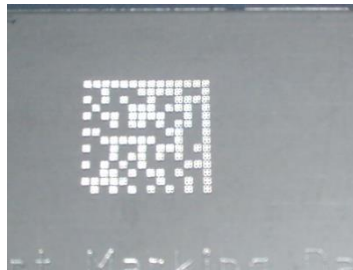

Figure 25 - Dot Peening Marking on Metal Surface with Multi-dot per Code Element

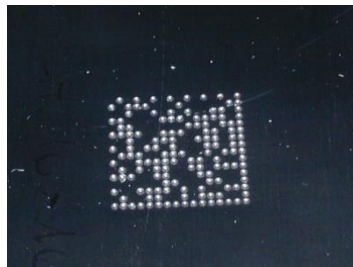

Figure 26 - Directly Marked Dot Matrix Code Characterized by Outstanding Separation Distance between Adjacent Code Elements

### 2.7.4 Ink-Jet Printing Technology

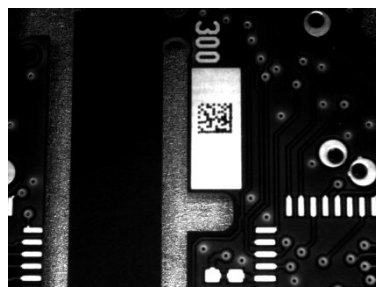

Figure 27 - Dot Matrix Code Directly Marked on PCB Copper Pad by Using Ink-Jet Technology

## 2.7.5 Laser Marking/Etching Technology



Figure 28 - Data Matrix Code Directly Marked on PCB Surface by Using Laser Etching Technology



**CAUTION:** If application codes must be read which are produced by Laser Marking in real time, use Matrix 210N models incorporating YAG Filters in order to avoid burning the CMOS sensor.

## 2.8 EXTERNAL LIGHTING SYSTEMS

In some direct part marking applications best reading results are obtained by using an external lighting system.

The LT-700 Linear Array Lighting System provides a high intensity light source designed for the following applications:

- with uneven, noisy and scratched surfaces
- where dot peening or laser etching codes are directly marked onto metal surfaces or PCBs and need to be highlighted. Here the use of more than one LT-700 at different positions can remove any shadowing effect.
- in the presence of highly reflective surfaces (metal, glass, etc.) causing direct reflections. Low light path to surface angles strongly reduce direct reflections.



Figure 29 - LT-700 Linear Array Lighting System

## 3 INSTALLATION

---

### 3.1 PACKAGE CONTENTS

Verify that the Matrix 210N reader and all the parts supplied with the equipment are present and intact when opening the packaging; the list of parts includes:

- Matrix 210N reader
- Quick Reference Guide
- Test Chart
- Mounting Kit
  - Mounting Screws (2)
  - Washers (2)
  - Mounting Bracket

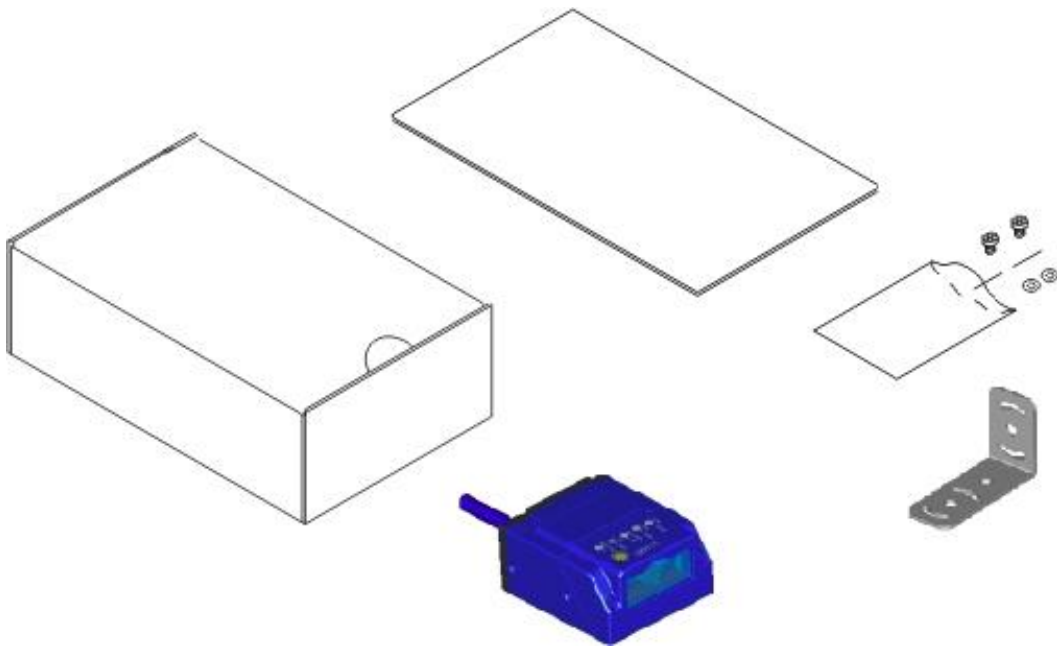

Figure 30 - Package Contents

### 3.2 MECHANICAL DIMENSIONS

Matrix 210N can be installed to operate in different positions. The four screw holes (M3 x 4) on the body of the reader are for mechanical fixture (Figure 31).

The diagram below gives the overall dimensions of the reader and may be used for its installation.

Refer to par. 3.3 for various mounting solutions and correct positioning and chp. 6 for Reading Distance considerations.

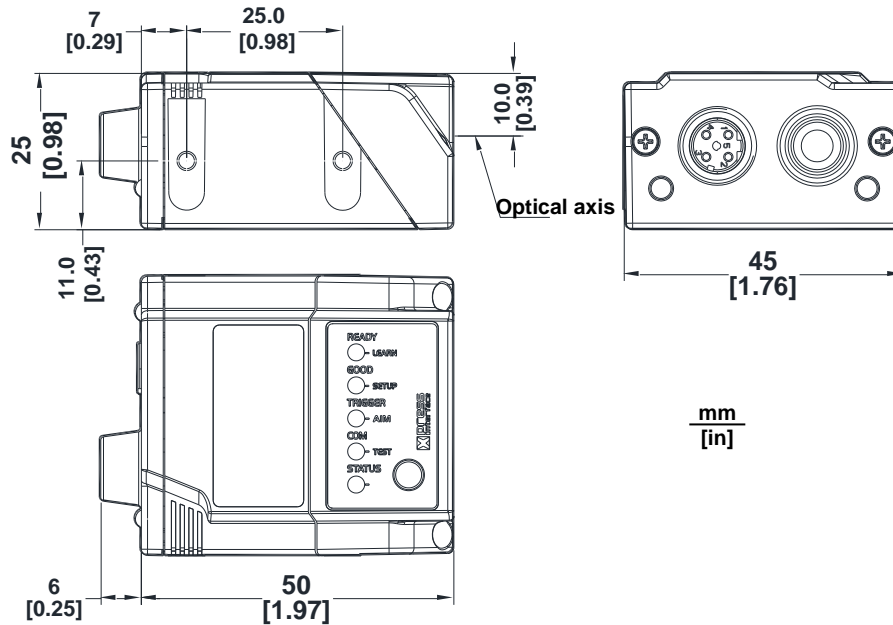

Figure 31 – Straight Model Overall Dimensions

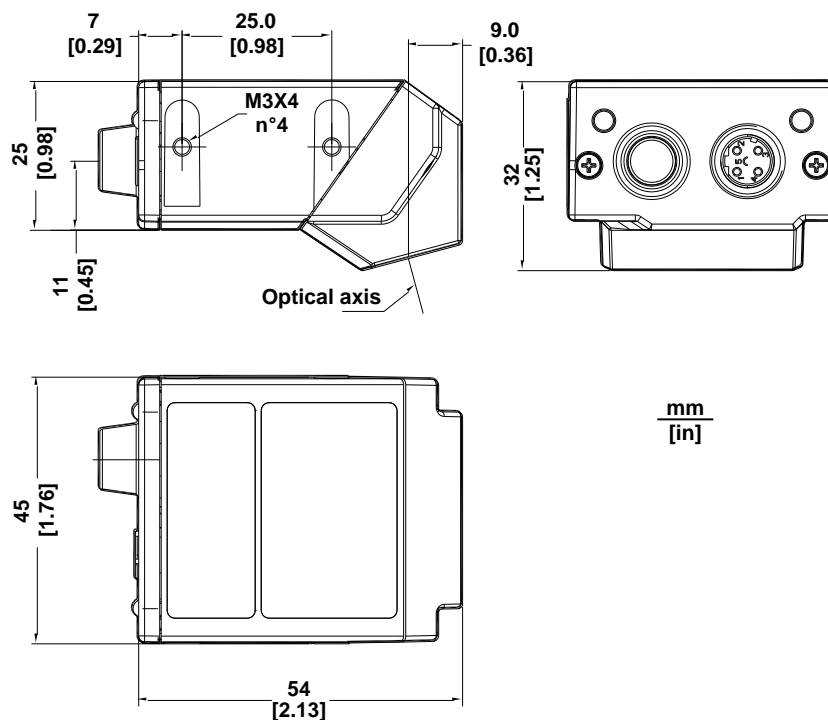

Figure 32 – 90° Model Overall Dimensions

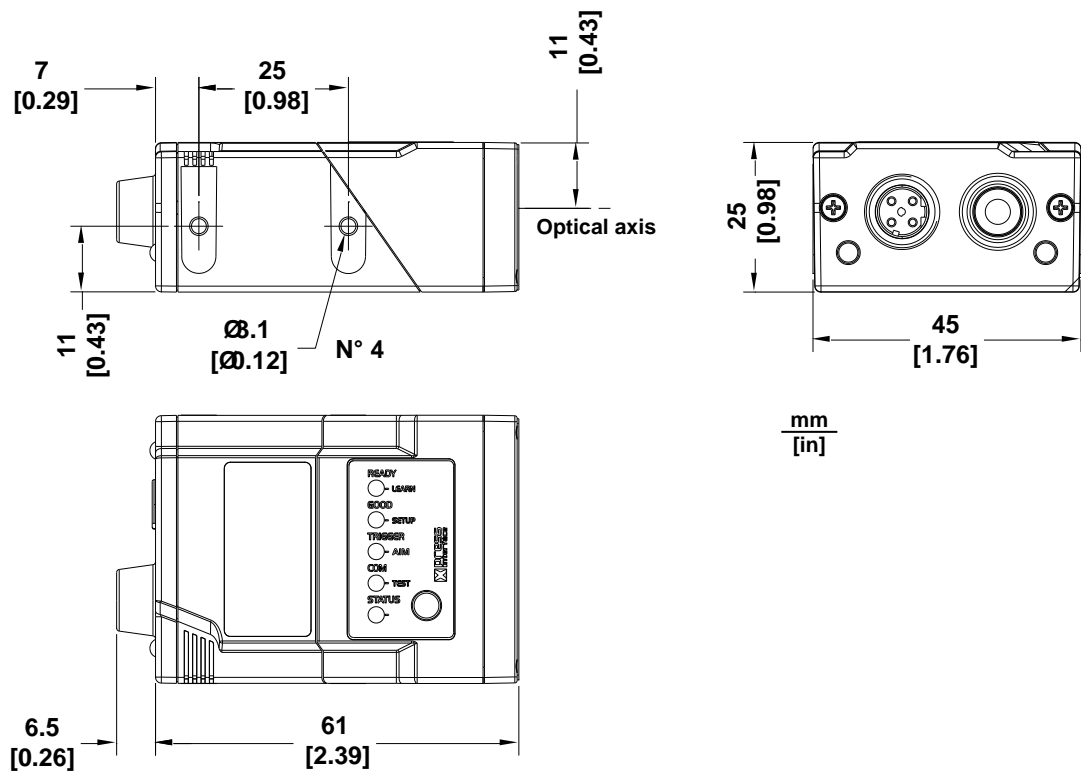

Figure 33 – Liquid Lens Model Overall Dimensions



### 3.3 MOUNTING AND POSITIONING MATRIX 210N

Using the Matrix 210N mounting brackets you can obtain rotation on the various axes of the reader as shown in the diagrams below:

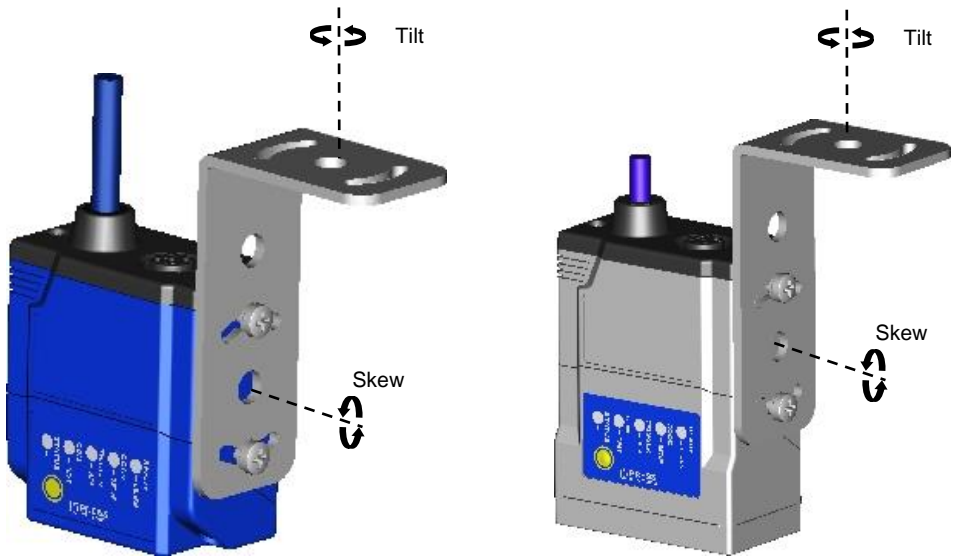

Figure 36 –Straight Model with ST-336 Mounting Bracket – External Positioning

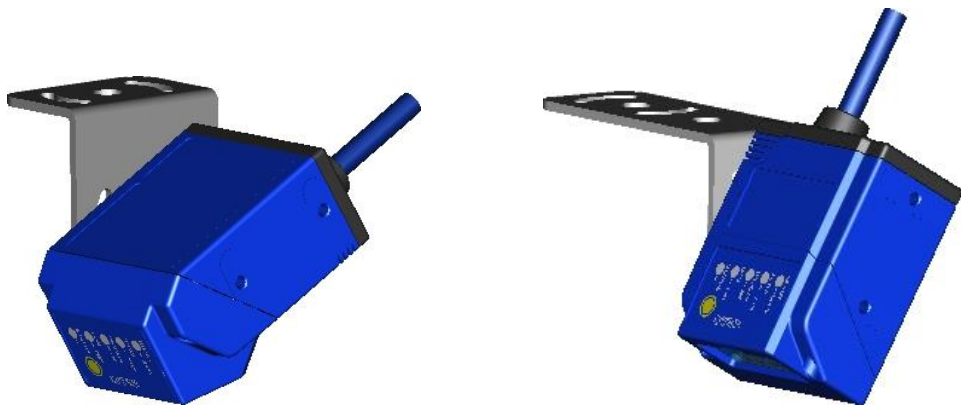

Figure 37 –Mounting Bracket External Positioning

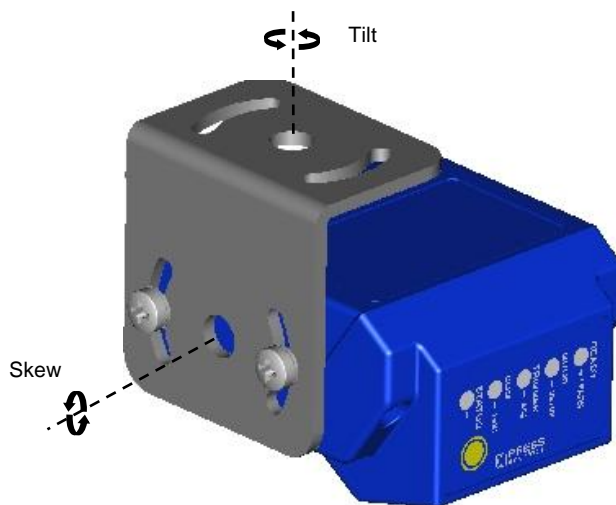

Figure 38 –90° Model with ST-337 Mounting Bracket - Internal Positioning



**NOTE:** For applications where strong vibrations or continuous bumps are present, it is recommended to use a double mounting bracket solution.

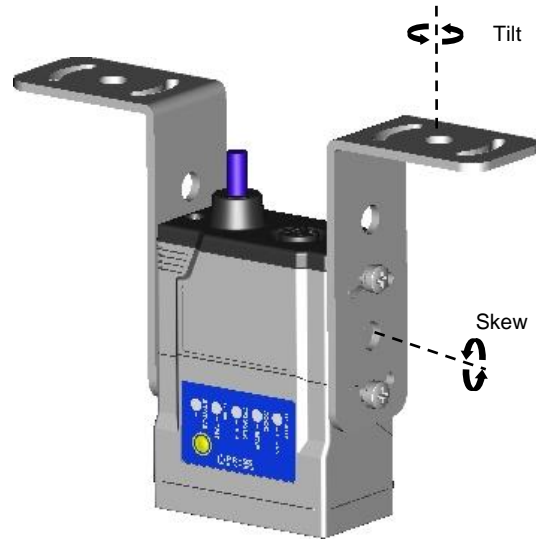

Figure 39 –Double Mounting Bracket Solution



Matrix 210N is able to decode code labels at a variety of angles, however significant angular distortion may degrade reading performance.

When mounting Matrix 210N, take into consideration these **ideal** label position angles: **Pitch or Skew 10° to 20° and Tilt 0°**.

**Note:** Since Matrix 210N is omni-directional on the code plane, the Pitch and Skew angles have the same significance with respect to the code plane. However in some advanced code reading applications performance can be improved by modifying the Skew angle.

The **Pitch, Skew and Tilt** angles are represented in Figure 40. Follow the suggestions below for the best orientation:

Position the reader in order to avoid the direct reflection of the light emitted by the Matrix 210N reader; it is advised to **assure at least 10°** for the Skew angle.

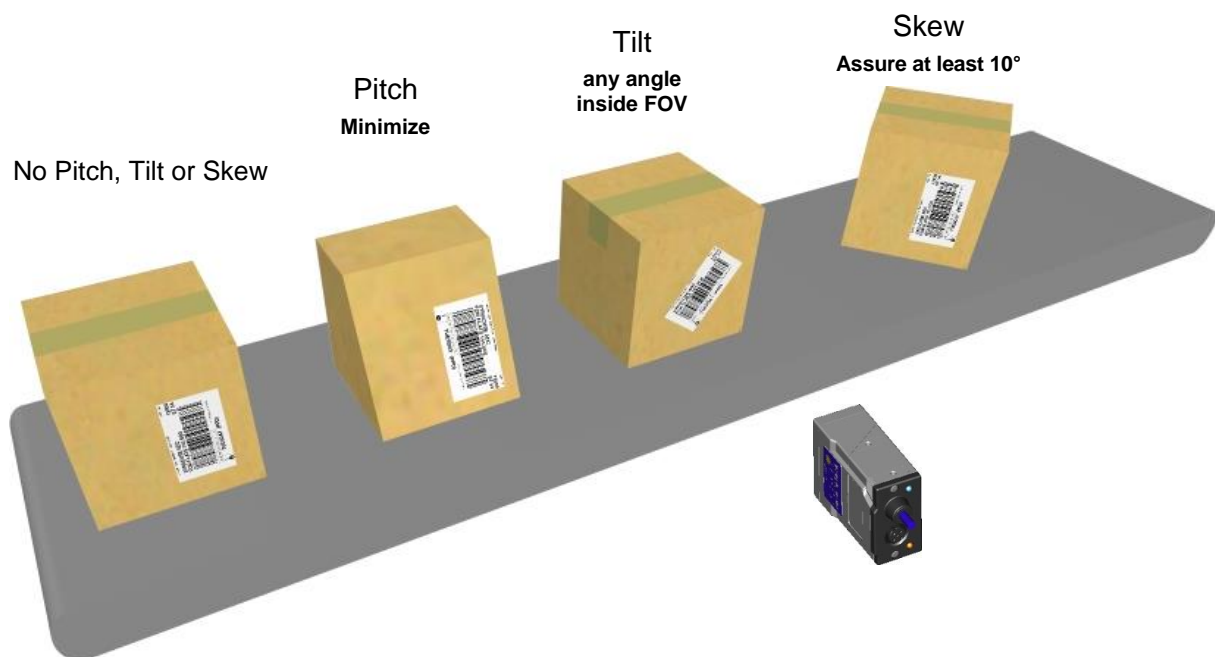

Figure 40 – Code Reading Orientation

In some cases, such as low contrast or low illumination, it can be useful to use a **Pitch or Skew** angle = 0°.

Matrix 210N can read labels with any tilt angle. Keep in mind however, that since linear barcodes are rectangular, the reader should be aligned to fit them into the horizontal FOV.

See chp. 6 for FOV and Reading Distance considerations.

## 4 CBX ELECTRICAL CONNECTIONS

The Matrix 210N can be directly connected to a CBX connection box.

We recommend making system connections through one of the CBX connection boxes since they offer the advantages of easy connection, easy device replacement and filtered reference signals.



**NOTE:** If you require direct wiring to the reader the details of the connector pins and relative connections are indicated in Appendix A.

The table below gives the pinout of the CBX100/500 terminal block connectors. Use this pinout when the Matrix 210N reader is connected by means of the CBX100/500:

CBX100/500 Terminal Block Connectors		
<b>Input Power</b>		
Vdc	Power Supply Input Voltage +	
GND	Power Supply Input Voltage -	
Earth	Protection Earth Ground	
<b>Inputs</b>		
+V	Power Source – External Trigger	
I1A	External Trigger A (polarity insensitive)	
I1B	External Trigger B (polarity insensitive)	
-V	Power Reference – External Trigger	
+V	Power Source – Inputs	
I2A	Input 2 A (polarity insensitive)	
I2B	Input 2 B (polarity insensitive)	
-V	Power Reference – Inputs	
<b>Outputs</b>		
+V	Power Source - Outputs	
-V	Power Reference - Outputs	
O1+	Output 1 +	
O1-	Output 1 -	
O2+	Output 2 +	
O2-	Output 2 -	
<b>Auxiliary Interface</b>		
TX	Auxiliary Interface TX	
RX	Auxiliary Interface RX	
SGND	Auxiliary Interface Reference	
<b>ID-NET</b>		
REF	Network Reference	
ID+	ID-NET network +	
ID-	ID-NET network -	
Shield	Network Cable Shield	
<b>Main Interface</b>		
	<b>RS232</b>	<b>RS422 Full-Duplex</b>
	TX	TX+
	RX	*RX+
	-	TX-
	-	*RX-
	SGND	SGND

\* Do not leave floating, see par. 4.2.2 for connection details.



**NOTE:** To avoid electromagnetic interference when the reader is connected to a CBX connection box, verify the jumper positions in the CBX as indicated in its Installation Manual.

### 4.1 POWER SUPPLY

Power can be supplied to the reader through the CBX100/500 spring clamp terminal pins as shown in Figure 41:

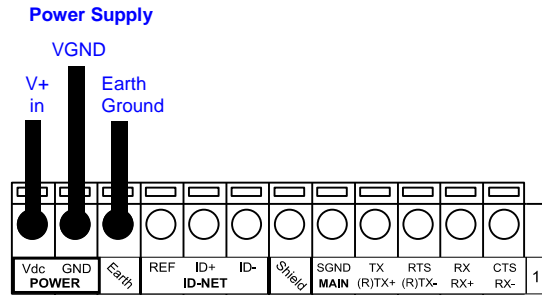

Figure 41 - Power Supply Connections

The power must be between 10 and 30 Vdc only.

It is recommended to connect the device CHASSIS to earth ground (Earth) by setting the appropriate jumper in the CBX connection box. See the CBX Installation Manual for details.

### 4.2 MAIN SERIAL INTERFACE



**CAUTION:** Do not connect to the Main Interface spring clamp terminals if using Host Interface Modules (Fieldbus) with the CBX500.

The signals relative to the following serial interface types are available on the CBX spring clamp terminal blocks.

**The main serial interface type and its parameters (baud rate, data bits, etc.) can be defined by the user via DL.CODE software. For more details refer to the Help On Line page of the Reading Phase step (Channels) in DL.CODE.**

Details regarding the connections and use of the interfaces are given in the next paragraphs.

### 4.2.1 RS232 Interface

The RS232 interface can be used for Point-to-Point connections. When it is connected to the host computer it allows transmission of code data.

The following pins are used for RS232 interface connection:

CBX100/500	Function
TX	Transmit Data
RX	Receive Data
SGND	Signal Ground

It is always advisable to use shielded cables. The overall maximum cable length must be less than 15 m (49.2 ft).

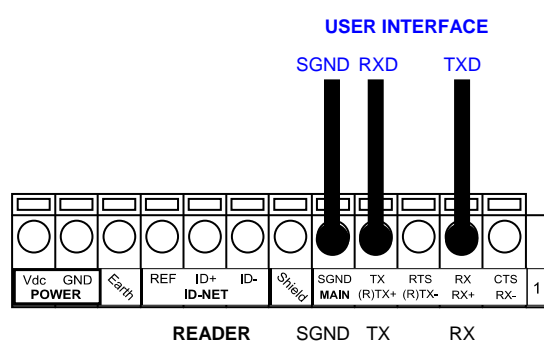

Figure 42 – RS232 Main Interface Connections

### 4.2.2 RS422 Full-Duplex Interface

The RS422 full-duplex (5 wires + shield) interface is used for non-pollled communication protocols in point-to-point connections over longer distances (max 1200 m / 3940 ft) than those acceptable for RS232 communications or in electrically noisy environments.

The CBX pinout follows:

CBX100/500	Function
TX+	RS422 Transmit Data +
RX+	RS422 Receive Data +
TX-	RS422 Transmit Data -
RX-	RS422 Receive Data -
SGND	Signal Ground

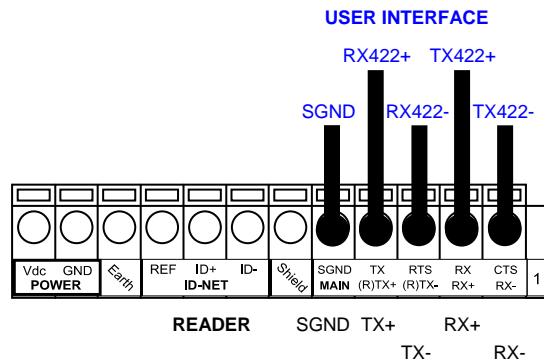

Figure 43 - RS422 Full-duplex Connections



**NOTE:** For applications that do not use RS422 transmission to the reader (terminal block RX+ and RX- signals), do not leave these lines floating but connect them to SGND as shown below.

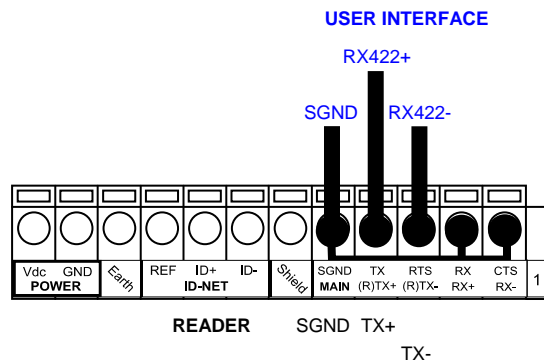

Figure 44 - RS422 Full-duplex Connections using Only TX Signals to Host

### 4.3 ID-NET INTERFACE

CBX100/500	Function
Shield	Network Cable Shield
ID+	ID-NET network +
ID-	ID-NET network -
REF	Network Reference

#### 4.3.1 ID-NET Cables

The following instructions are referred to Figure 46, Figure 47 and Figure 48.

- The general cable type specifications are: CAT5 twisted pair + additional CAT5 twisted pair, shielded cable AWG 24 (or AWG 22) stranded flexible.

We recommend using DeviceNet cables (drop or trunk type) to the following reference standards:

AN50325 – IEC 62026

UL STYLE 2502 80°C 30V

- Cable Shield MUST be connected to earth ground ONLY at the Master.
- NEVER use ID-NET cable shield as common reference.
- The ID-NET max cable length depends on the baudrate used, (see the Baudrate Table below).
- For Common Power Connections use only 2 wires (ID+ and ID-).
  - DC Voltage Power cable (Vdc – GND) should be handled as a signal cable (i.e. do not put it together with AC cable):
  - Wire dimensioning must be checked in order to avoid voltage drops greater than 0.8 Volts.
  - Cable should lie down as near as possible to the ID-NET cable (avoiding wide loops between them).
- Reader's chassis may be connected to earth.
- Network inside the same building.

Baudrate Table				
Baud Rate	125 kbps	250 kbps	<b>500 kbps</b>	1Mbps
Cable Length	1200 m	900 m	<b>700 m</b>	*

\* Application dependent, contact your Datalogic representative for details.



**NOTE:** The default ID-NET baudrate is 500 kbps. Lower ID-NET baudrates allow longer cable lengths.

### 4.3.2 ID-NET Response Time

The following figure shows the response time of the ID-NET network. This time is defined as the period between the Trigger activation and the beginning of data transmission to the Host.

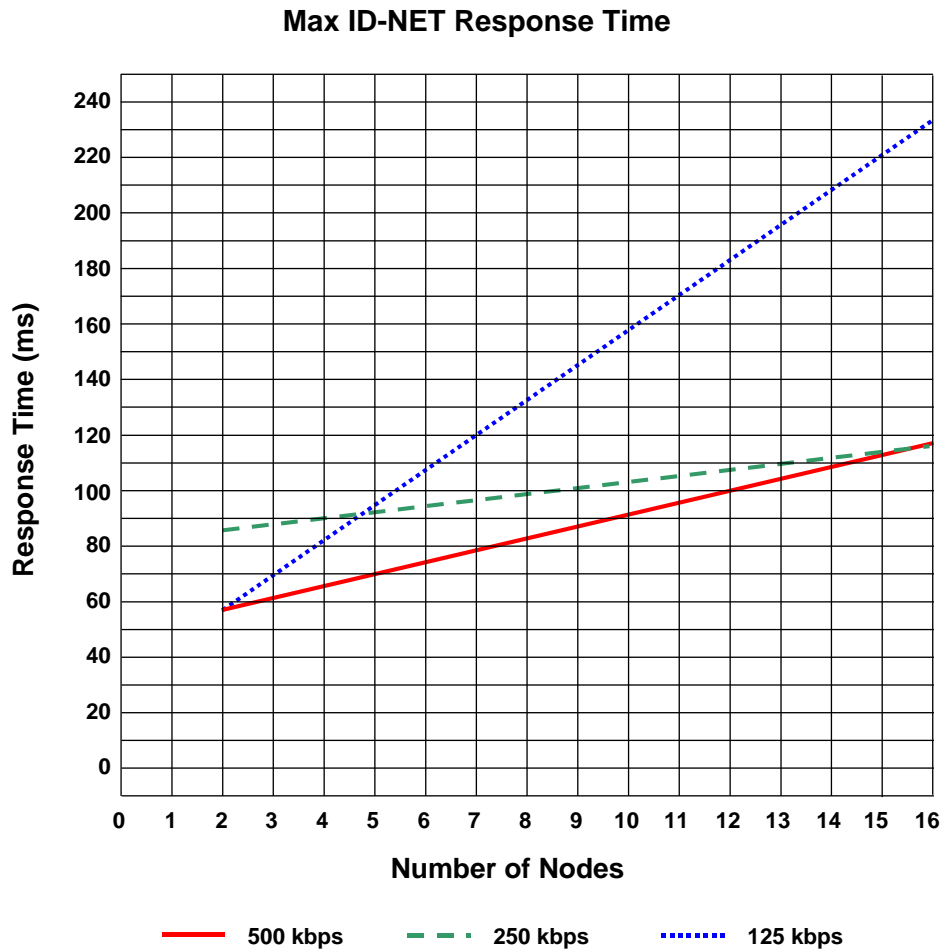

Figure 45 – ID-NET Response Time

**CONDITIONS:**

- ID-NET M/S Synchronized layout
- message length = 50 bytes per node

### 4.3.3 ID-NET Network Termination

The network must be properly terminated in the first and last reader of the network. This is done by setting the ID-NET Termination Resistance Switch in the CBX100/500 to ON.

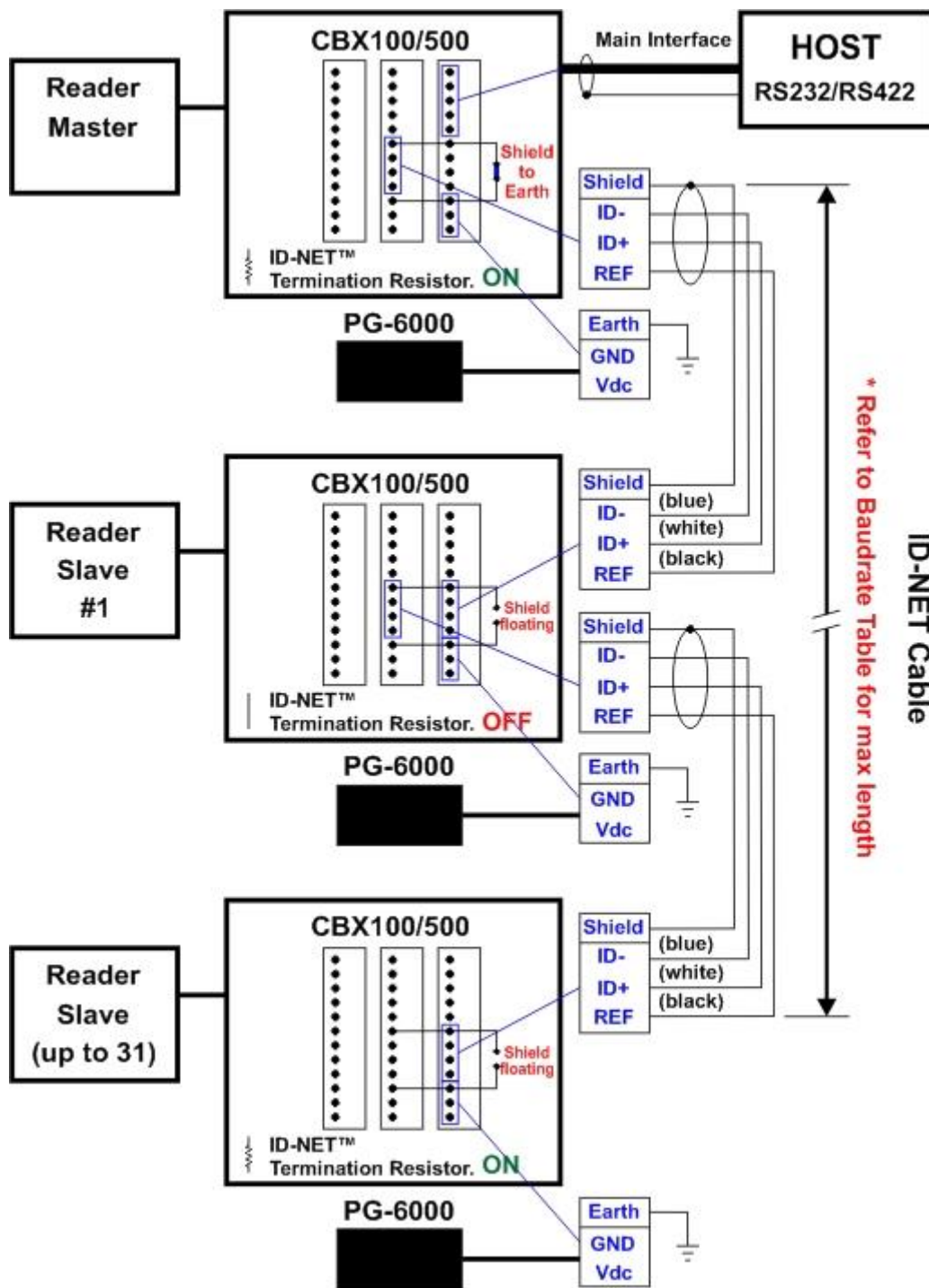

Figure 46 – ID-NET Network Connections with isolated power blocks



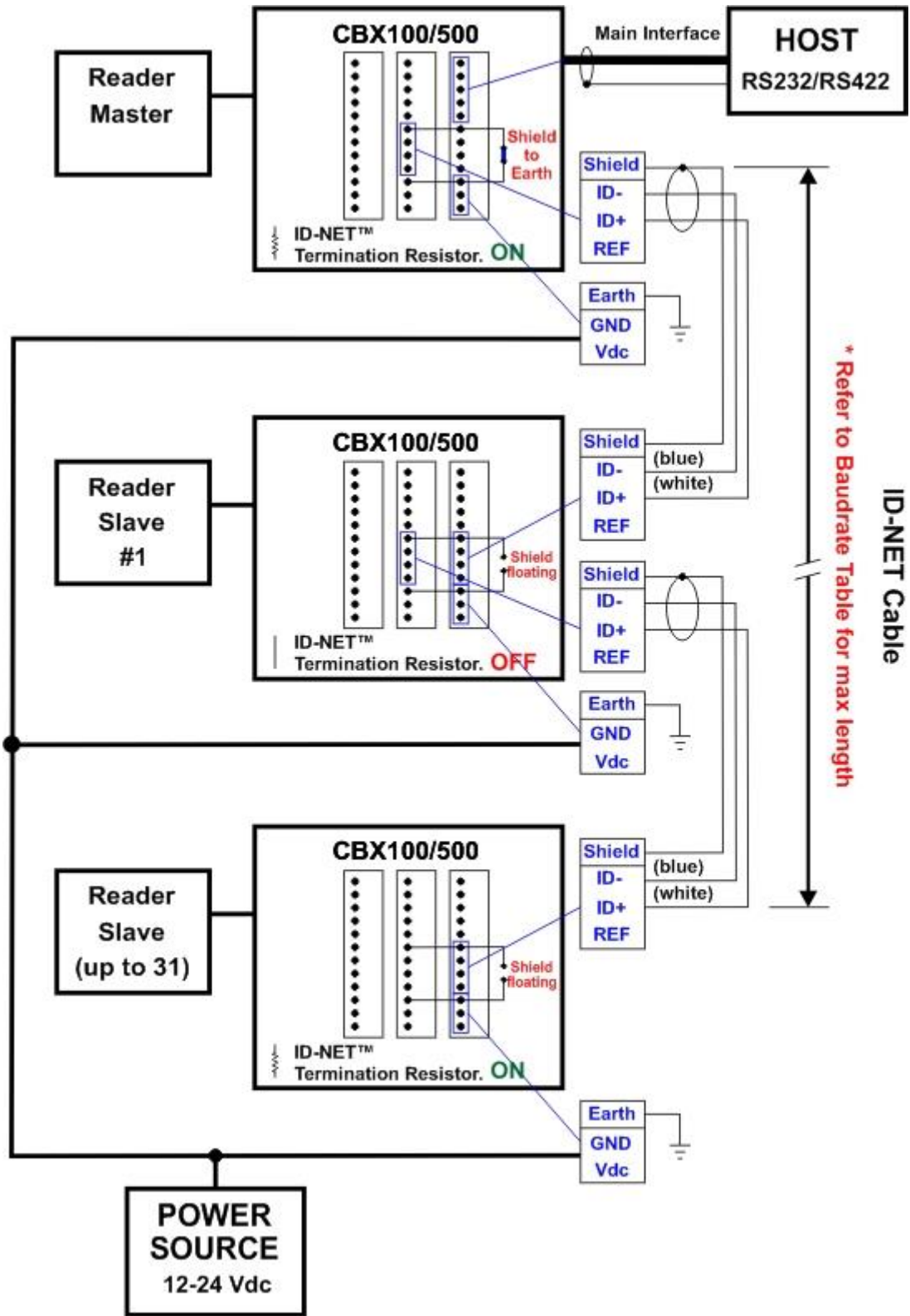

Figure 47 - ID-NET Network Connections with Common Power Branch Network

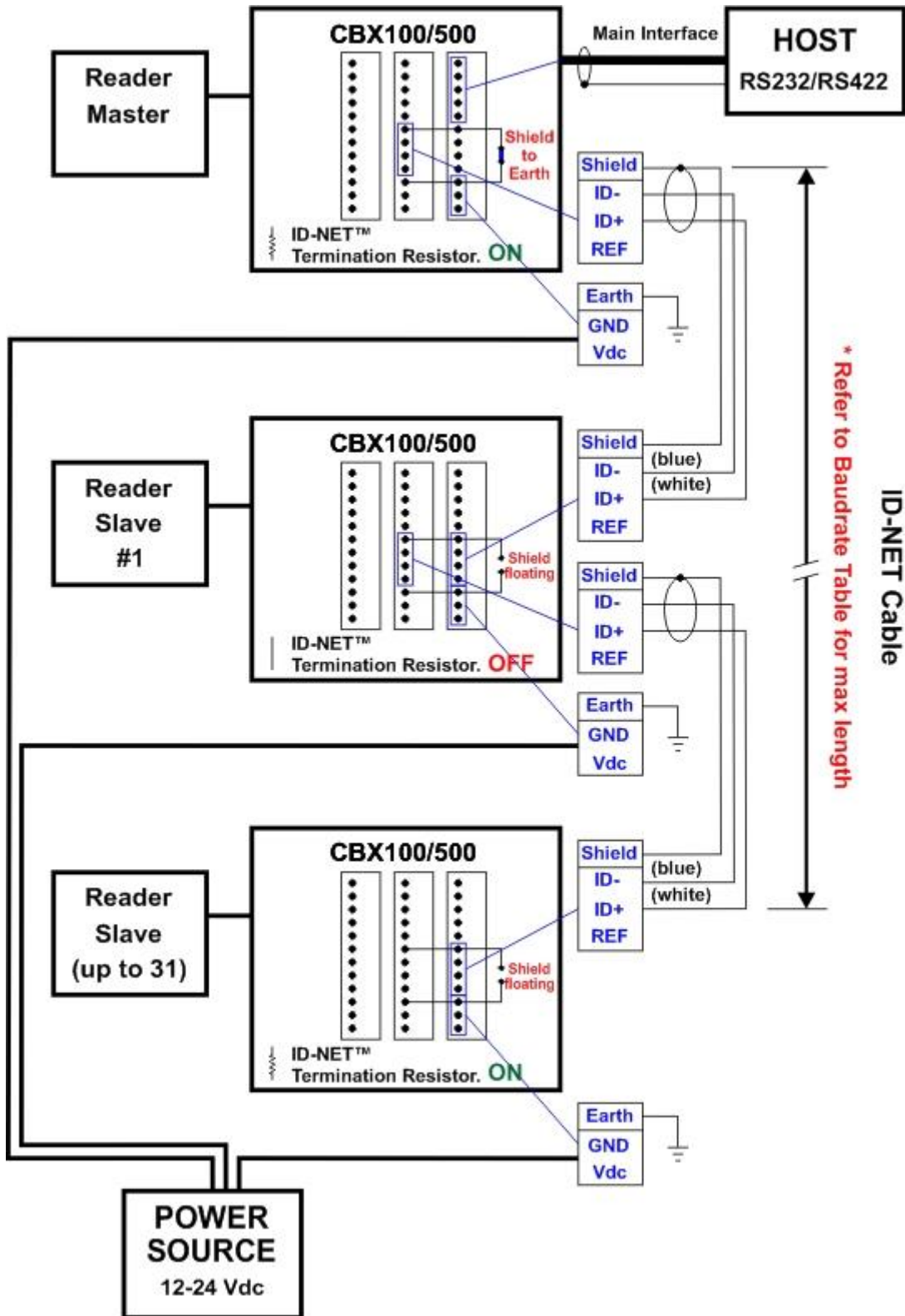

Figure 48 – ID-NET Network Connections with Common Power Star Network

### 4.4 AUXILIARY RS232 INTERFACE

The RS232 auxiliary interface is available for Point-to-Point connections. When it is connected to the host computer it allows transmission of code data.

The parameters relative to the aux interface (baud rate, data bits, etc.) can be defined through the Reading Phase step (Channels) in DL.CODE.

The 9-pin female Auxiliary Interface connector inside the CBX is the preferred connector for temporary communication monitoring.

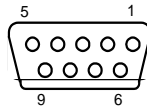

Figure 49 - 9-pin female connector

If permanent system wiring is required, the following pins are used to connect the RS232 auxiliary interface:

CBX100/500	Function
RX	Auxiliary Interface Receive Data
TX	Auxiliary Interface Transmit Data
SGND	Auxiliary Interface Reference

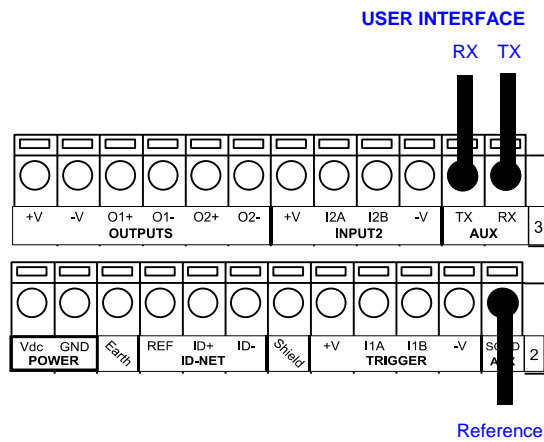

Figure 50 - RS232 Auxiliary Interface Connections



**NOTE:** Do not connect the Aux Interface to the CBX spring clamp connectors and the 9-pin connector simultaneously.

## 4.5 INPUTS

There are two optocoupled polarity insensitive inputs available on the reader: Input 1 (External Trigger) and Input 2, a generic input:

The External Trigger can be used in One Shot Mode or in Phase Mode. Its main functions are:

- acquisition trigger in One Shot Mode
- reading phase-ON/reading phase-OFF command in Phase Mode

The main functions of the general purpose Input 2 are:

- second external trigger in Phase Mode
- match code storage command when the Match Code option is enabled

The electrical features of both inputs are:

$$V_{AB} = 30 \text{ Vdc max.}$$

$$I_{IN} = 12 \text{ mA (reader) + 12 mA (CBX) max.}$$

The active state of these inputs is selected in software.

An anti-disturbance filter, by default, is implemented in software on both inputs. The value can be changed through the software parameter Debounce Filter. See the Help On Line page of the Reading Phase step (Inputs) in DL.CODE for further details on these parameters.

These inputs are optocoupled and can be driven by both NPN and PNP type commands.



**NOTE:** Polarity insensitive inputs assure full functionality even if pins A and B are exchanged.

The connections are indicated in the following diagrams:

CBX100/500	Function
+V	Power Source - External Trigger
I1A	External Trigger A (polarity insensitive)
I1B	External Trigger B (polarity insensitive)
-V	Power Reference - External Trigger

The yellow Trigger LED (Figure 19, 5) is on when the active state of the External Trigger corresponds to ON.

**EXTERNAL TRIGGER INPUT CONNECTIONS USING MATRIX 210N POWER**



**CAUTION:** Power from the Vdc/GND spring clamps is available directly to the Input Device on the +V/-V spring clamps, and does not pass through the Power Switch (ON/OFF) inside the CBX. Disconnect the power supply when working inside the CBX.

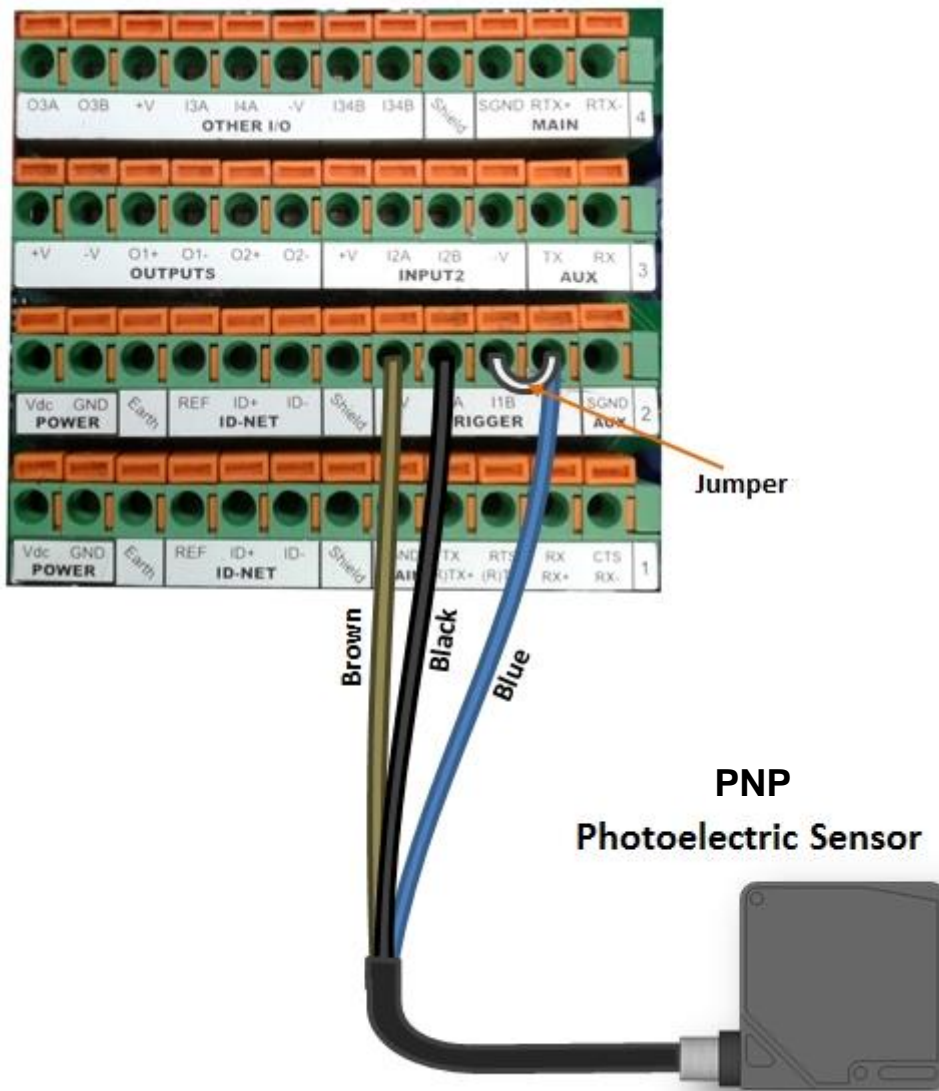

Figure 51 – PNP External Trigger Using Matrix 210N Power

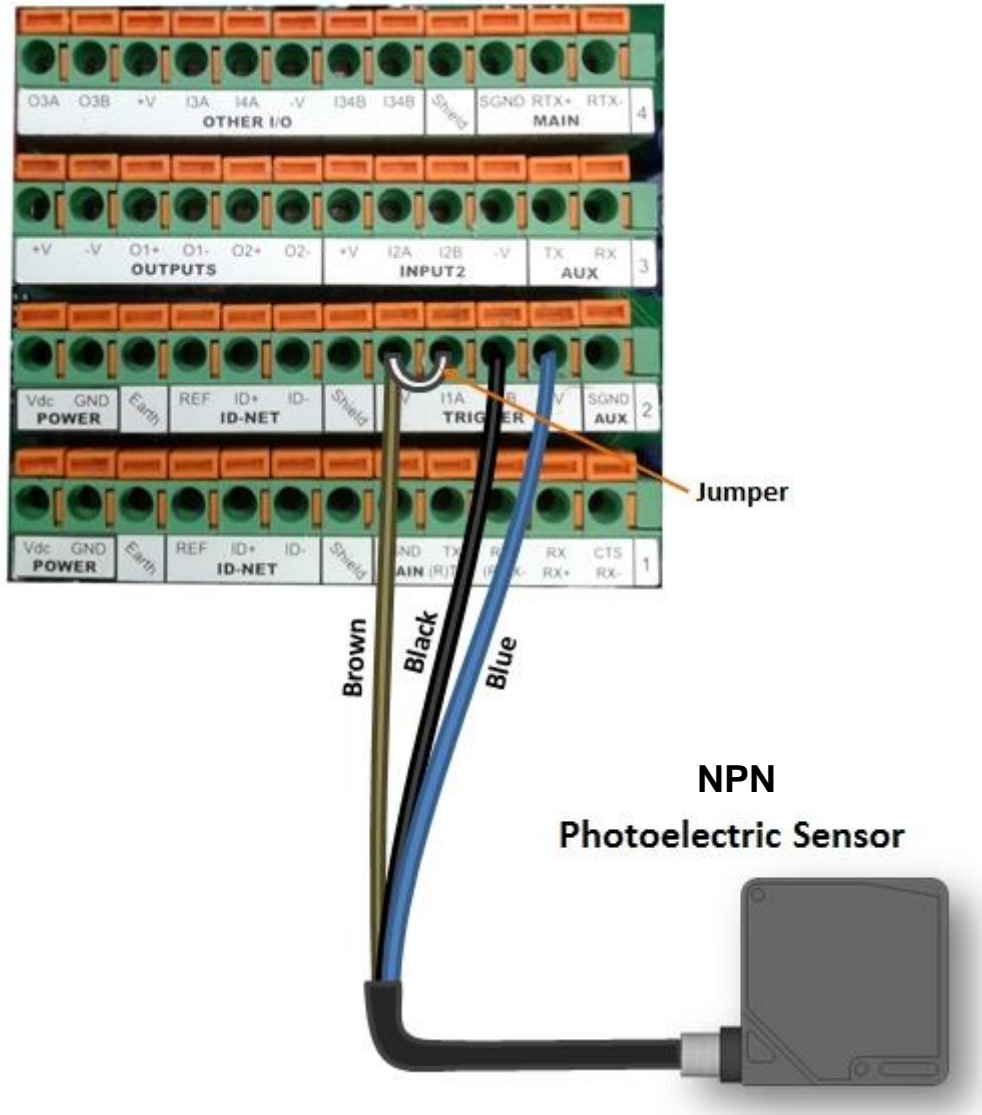

Figure 52 - NPN External Trigger Using Matrix 210N Power

EXTERNAL TRIGGER INPUT CONNECTIONS USING EXTERNAL POWER

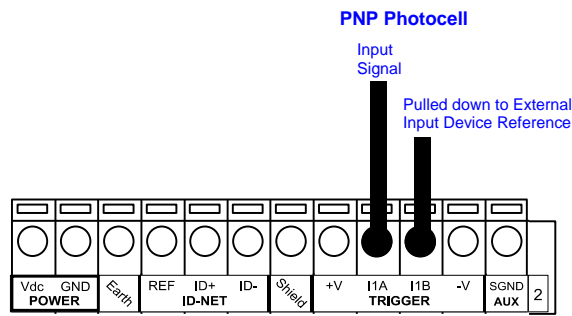

Figure 53 - PNP External Trigger Using External Power

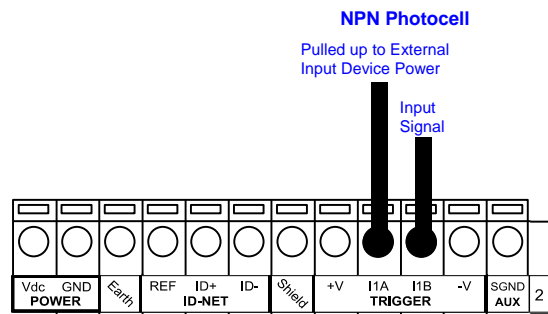

Figure 54 - NPN External Trigger Using External Power

CBX100/500	Function
+V	Power Source - Inputs
I2A	Input 2 A (polarity insensitive)
I2B	Input 2 B (polarity insensitive)
-V	Power Reference - Inputs

INPUT 2 CONNECTIONS USING MATRIX 210N POWER



**CAUTION:** Power from the Vdc/GND spring clamps is available directly to the Input Device on the +V/-V spring clamps, and does not pass through the Power Switch (ON/OFF) inside the CBX. Disconnect the power supply when working inside the CBX.

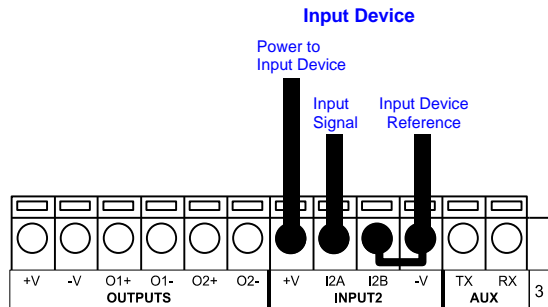

PNP Input 2 Using Matrix 210N Power

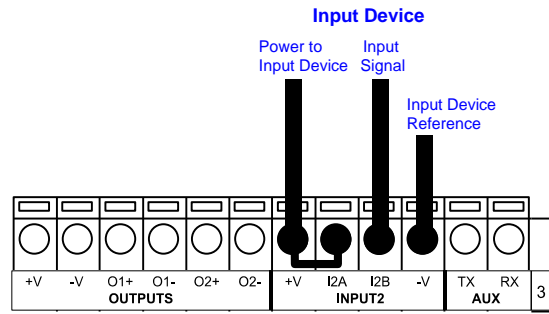

NPN Input 2 Using Matrix 210N Power

INPUT 2 CONNECTIONS USING EXTERNAL POWER

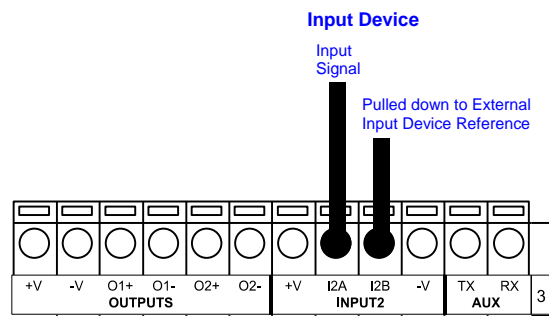

Figure 55 - PNP Input 2 Using External Power  
Input Device

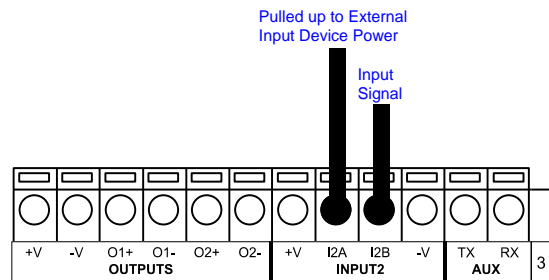

Figure 56 - NPN Input 2 Using External Power



## 4.6 OUTPUTS

Two optocoupled general purpose outputs are available. The meaning of the two outputs Output 1 and Output 2 can be defined by the user. They are typically used either to signal the data collection result or to control an external lighting system.

CBX100/500	Function
+V	Power Source - Outputs
O1+	Output 1 +
O1-	Output 1 -
O2+	Output 2 +
O2-	Output 2 -
-V	Power Reference Outputs

The electrical features of the two outputs are the following:

$$V_{CE} = 30 \text{ Vdc max.}$$

$$I_{CE} = 40 \text{ mA continuous max.; } 130 \text{ mA pulsed max.}$$

By default, Output 1 is associated with the No Read event, which activates when the code(s) signaled by the external trigger are not decoded, and Output 2 is associated with the Good Read event, which activates when all the selected codes are correctly decoded.

The output signals are fully programmable being determined by the configured Activation/Deactivation events, Deactivation Timeout or a combination of the two. Refer to the DL.CODE parameters Help On Line for further details.

### OUTPUT CONNECTIONS USING MATRIX 210N POWER



**CAUTION:** Power from the Vdc/GND spring clamps is available directly to the Output Device on the +V/-V spring clamps, and does not pass through the Power Switch (ON/OFF) inside the CBX. Disconnect the power supply when working inside the CBX.

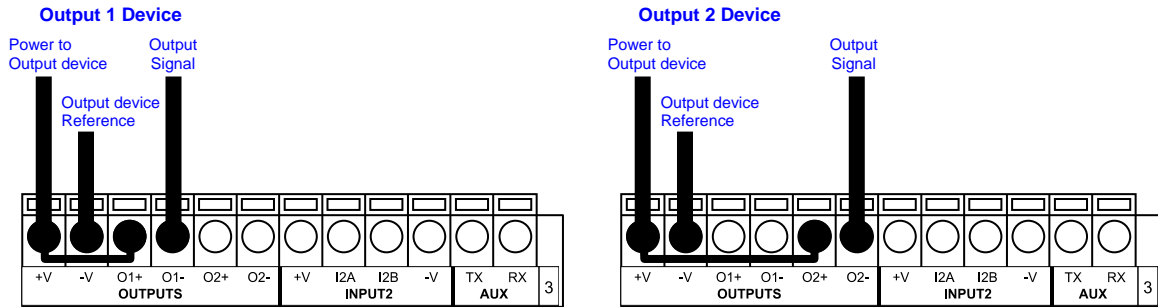

Figure 57 - Open Emitter Output Using Matrix 210N Power

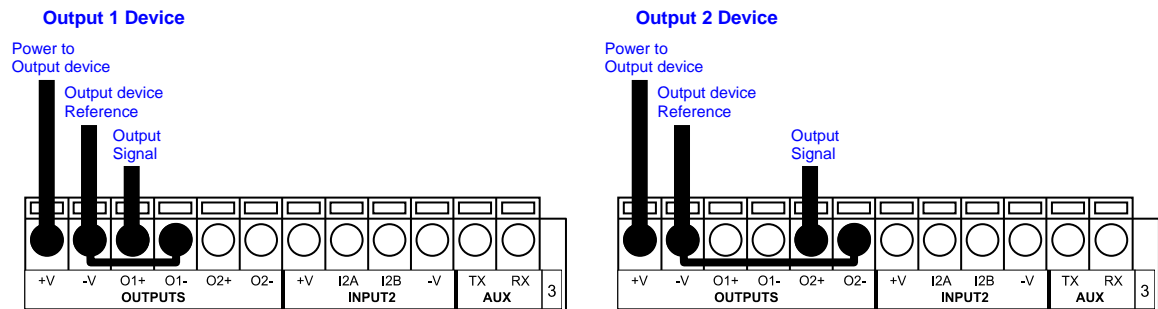

Figure 58 - Open Collector Output Using Matrix 210N Power

### OUTPUT CONNECTIONS USING EXTERNAL POWER

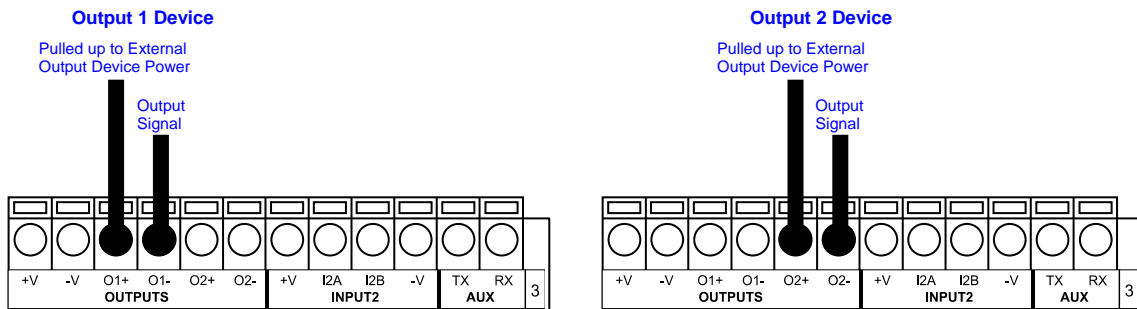

Figure 59 - Output Open Emitter Using External Power

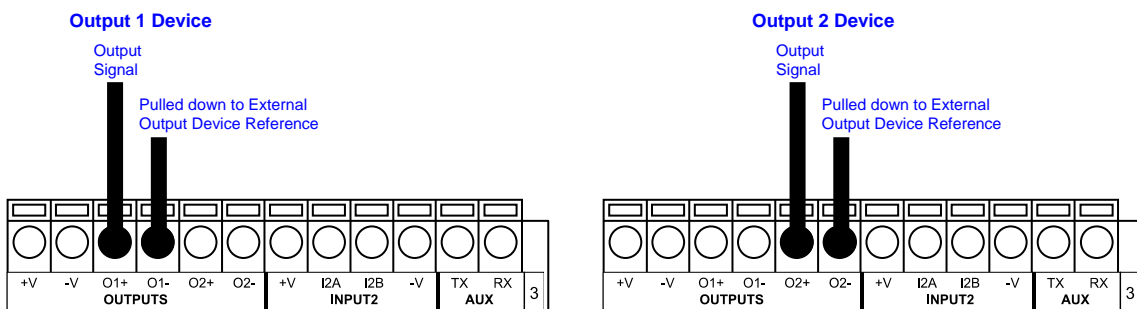

Figure 60 - Output Open Collector Using External Power

### 4.7 EXTERNAL LIGHTING SYSTEMS

If an External Illuminator is used, it can be powered from the CBX connection box. It must be connected to the **Vdc** and **GND** terminal clamps.



**CAUTION:** Power is available directly to the Illuminator, independently from the Power Supply Switch inside the CBX. Disconnect the power supply when working inside the CBX.

In the case of the LT-700 illuminator, one of the available digital outputs must be connected as the control signal. In DL.CODE, configure the Output Line Function parameter to one of the External Illuminator selections: Always On or Strobed.

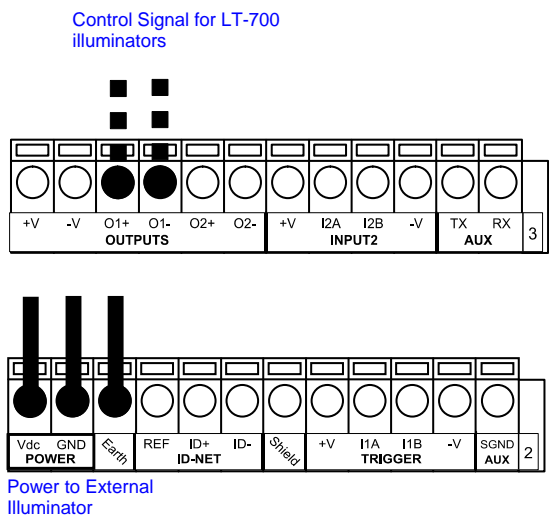

**Figure 61 – External Lighting System Connections**

Below is a table summarizing the External Illuminator wiring and power requirements:

Illuminator	Wire Color	CBX/Matrix Signal	Meaning
LT-700	Red	Vdc	10 to 30 Vdc
	Black	GND	Ground
	White	Earth	Shield/Earth Ground
	Green	O1- or O2-	Control Signal -
	Yellow	O1+ or O2+	Control Signal +

## 4.8 ON-BOARD ETHERNET INTERFACE

The on-board Ethernet Interface can be used for TCP/IP communication with a remote or local host computer by connecting the reader to either a LAN or directly to a host PC. There is no need to use a crossover adapter since Matrix 210N incorporates an auto-cross function.

A **CAB-ETH-M0x** cable can be used to connect to a LAN.

On the Matrix 210N on-board Ethernet interface the following communication channels are available:

- TCP Client
- TCP Server
- UDP Channel
- FTP Client

The following Fieldbus protocols are also available over the on-board Ethernet interface:

- EtherNet/IP
- PROFINET IO
- Modbus TCP Client

For further details refer to the Help On Line page of the Reading Phase step (Channels) and (Fieldbuses) in DL.CODE.

## 4.9 USER INTERFACE – SERIAL HOST

The following table contains the pinout for standard RS232 PC Host interface. For other user interface types please refer to their own manual.

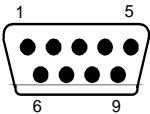
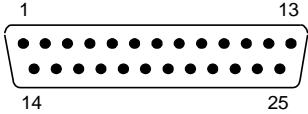
RS232 PC-side connections			
 <p>9-pin male connector</p>		 <p>25-pin male connector</p>	
Pin	Name	Pin	Name
2	RX	3	RX
3	TX	2	TX
5	GND	7	GND

## 5 TYPICAL LAYOUTS

The following typical layouts refer to system hardware configurations. However, they also require the correct setup of the software configuration parameters. Dotted lines in the figures refer to optional hardware configurations within the particular layout.



**NOTE:** All software configurations are made through DL.CODE which connects to the reader through the on-board Ethernet interface.



**NOTE:** DL.CODE now supports several different multi device configuration types using the PASS-THROUGH configuration. In particular this feature allows MULTIDATA ID-NET network configurations to be made. Master/Slave SYNCHRONIZED ID-NET network configurations are also configurable as before.



**NOTE:** The Master/Slave Role is only significant for the Internal ID-NET Network. If your layout doesn't use the ID-NET network then the device's Role is not significant and can be ignored.

### 5.1 ETHERNET CONNECTION

The Ethernet connection is possible in two different layouts.

In a Point-to-Point layout the reader is connected to a local host by using a **CAB-ETH-M0x** cable. There is no need to use a crossover adapter since Matrix 210N incorporates an auto-cross function.

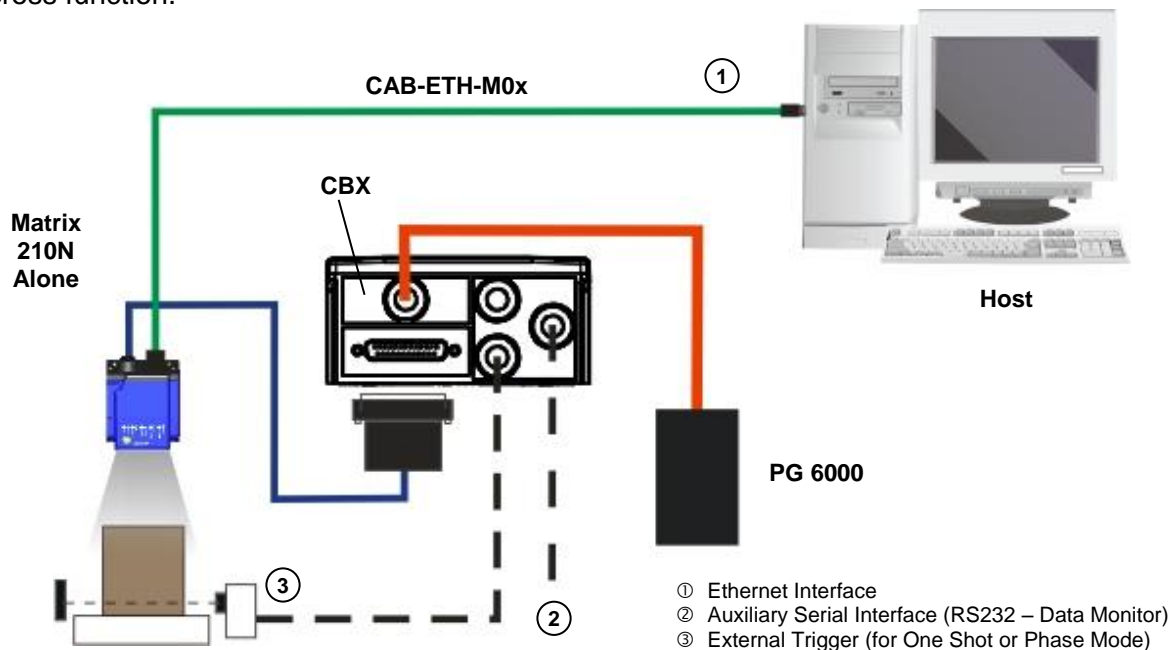

Figure 62 - Ethernet Point-to-Point Layout

All devices always support multiple output channels (i.e. for data monitoring).

When using a Local Area Network (LAN), one or more Matrix 210N readers can be connected to the network by using **CAB-ETH-M0x** cables:

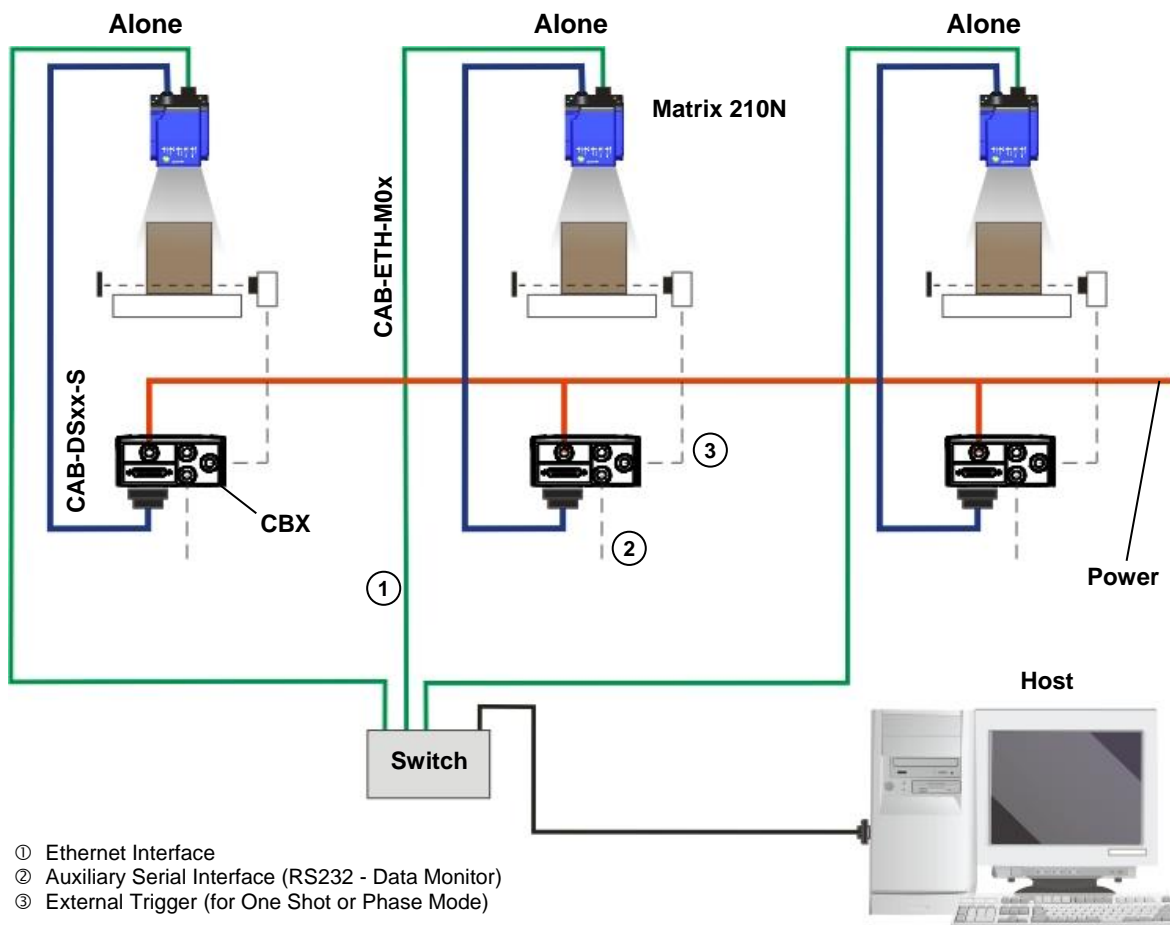

Figure 63 - Ethernet Network Layout

## 5.2 SERIAL CONNECTION

In this layout the data is transmitted to the Host on the main serial interface. The Ethernet interface can be used for reader configuration by connecting a laptop computer running DL.CODE.

Data can be transmitted on the RS232 auxiliary interface independently from the main interface selection to monitor data.

When One Shot or Phase Mode operating mode is used, the reader can be activated by an External Trigger (for example a pulse from a photoelectric sensor) when the object enters its reading zone.

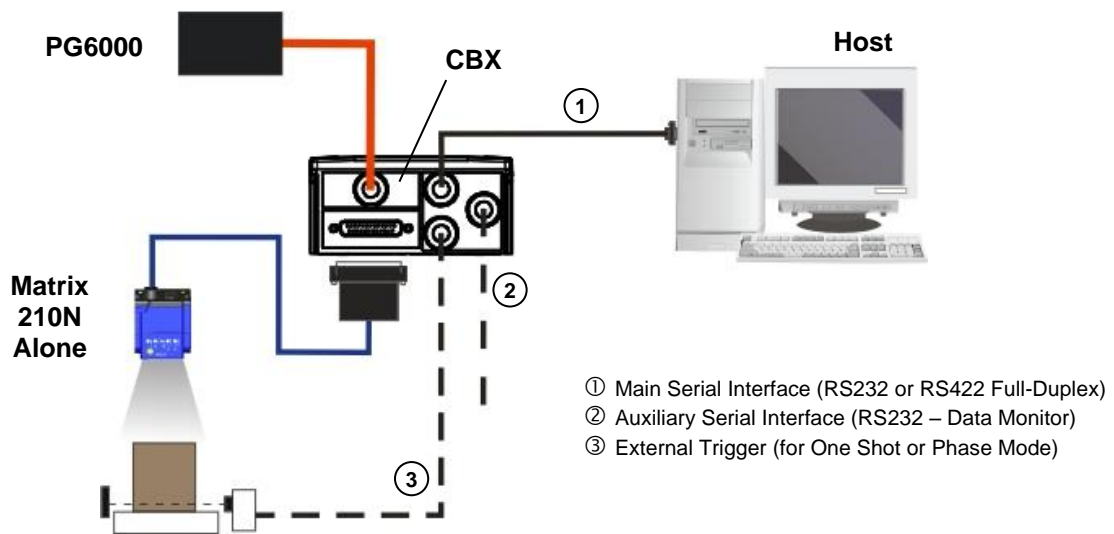

Figure 64 – Serial Interface Point-to-Point Layout

All devices always support multiple output channels (i.e. for data monitoring).

### 5.3 FIELDBUS CONNECTION

In this layout a single reader functions as a Slave node on a Fieldbus network. The data is transmitted to the Host through an accessory Fieldbus interface board installed inside the CBX500 connection box.

Reader configuration can be accomplished through the Ethernet interface using the DL.CODE configuration program.

Data can be transmitted on the RS232 auxiliary interface independently from the Fieldbus interface selection to monitor data.

When One Shot or Phase Mode operating mode is used, the reader can be activated by an External Trigger (photoelectric sensor) when the object enters its reading zone.

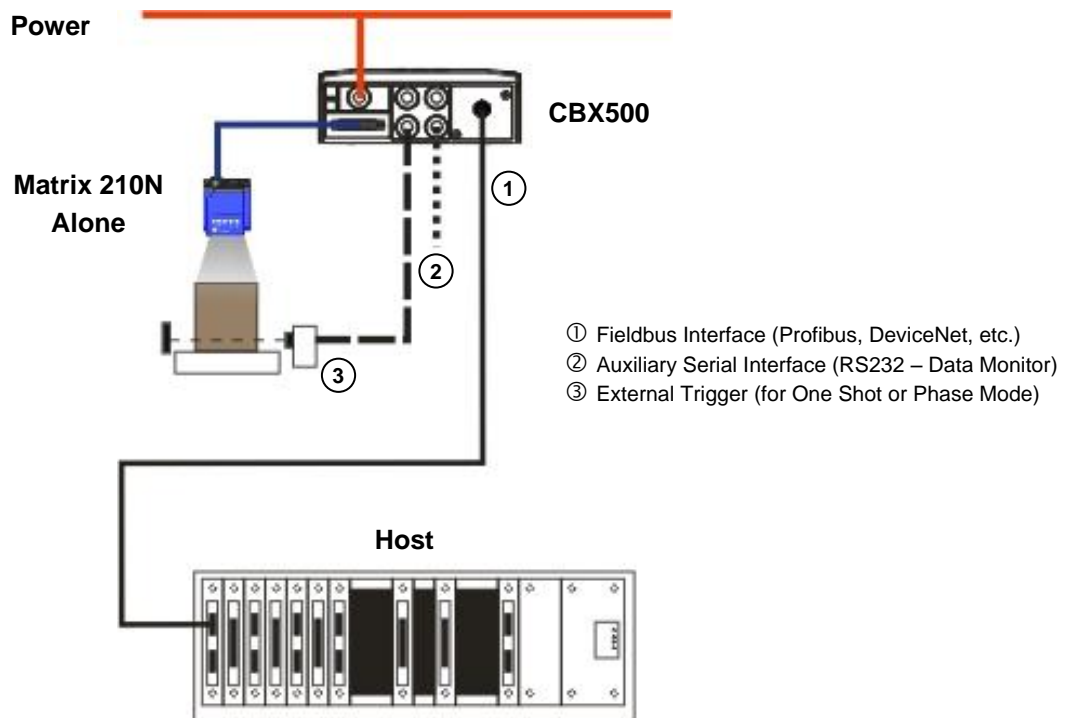

Figure 65 – Fieldbus Interface Point-to-Point Layout

All devices always support multiple output channels (i.e. for data monitoring).



## 5.4 PASS-THROUGH

The pass-through layout allows each device **working Alone**, to collect data from one or more pass-through input channels and send this data plus its own on one or more different output channels.

In this way independent devices can be connected together in combinations to create multi device networks. Many devices reading independently can send their messages through a common output channel which instead of being directed at a Host can be collected by another device on its pass-through input channel and sent to a Host on a different output channel.

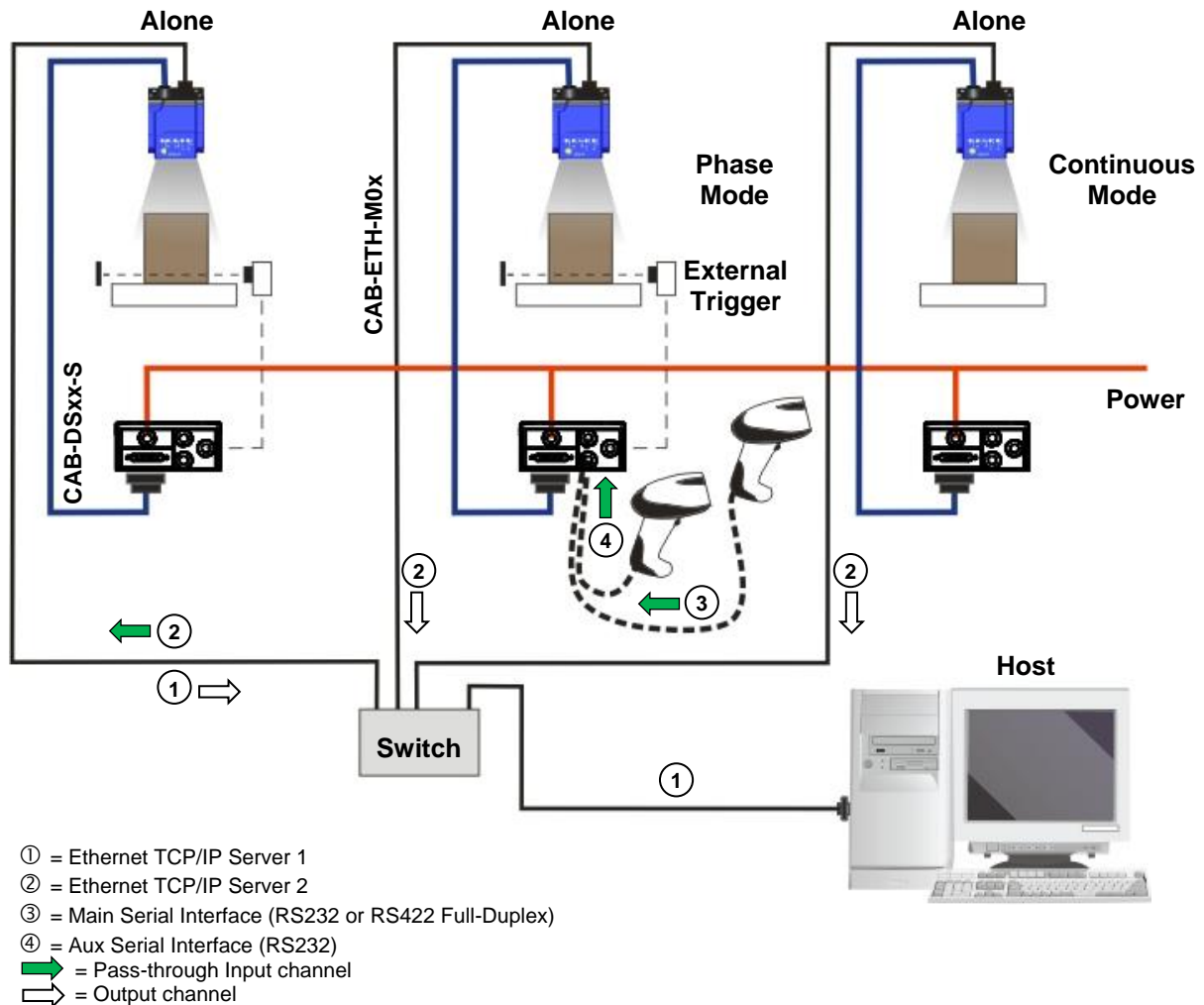

Figure 66 – Pass-through Layout

In a Pass-through layout each device supports multiple pass-through configurations to accept input from different devices on different channels (i.e. middle reader above). However, readers are not required to have a pass-through configuration if they don't need to receive data from an input channel (i.e. right reader above). The overall data collection device always has at least one pass-through configuration to collect the input data from the other devices and send it to the Host (i.e. left reader above).

All devices always support multiple output channels (i.e. for data monitoring).

In a Pass-through layout each device can have a different operating mode: Continuous, One Shot, Phase Mode, etc.



## 5.6 ID-NET SYNCHRONIZED NETWORK

When the device is **working Synchronized**, the ID-NET connection is used to collect data from several readers to build a multi-point or a multi-sided reading system; there can be one Master and up to 31 Slaves connected together.

The Slave readers are connected together using the ID-NET interface. Every Slave reader must have an ID-NET address in the range 1-31.

The Master reader is also connected to the Host on one of its communication channels. In the following examples the RS232/RS422 main serial interface is used.

For a Master/Slave Synchronized layout the External Trigger signal is unique to the system; there is a single reading phase and a single message from the Master reader to the Host computer. **It is not necessary to bring the External Trigger signal to all the readers.**

In the Master/Slave Synchronized layout the Master operating mode can only be set to Phase Mode.

The Main and ID-NET interfaces are connected as shown in the following figures.

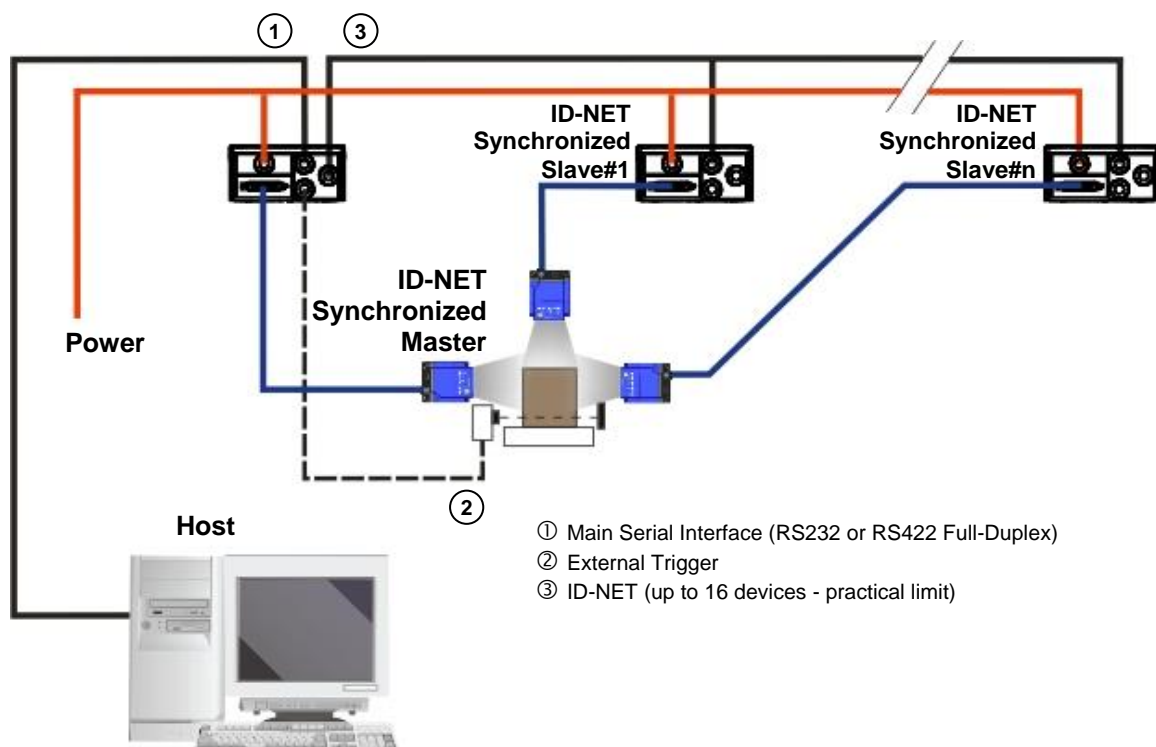
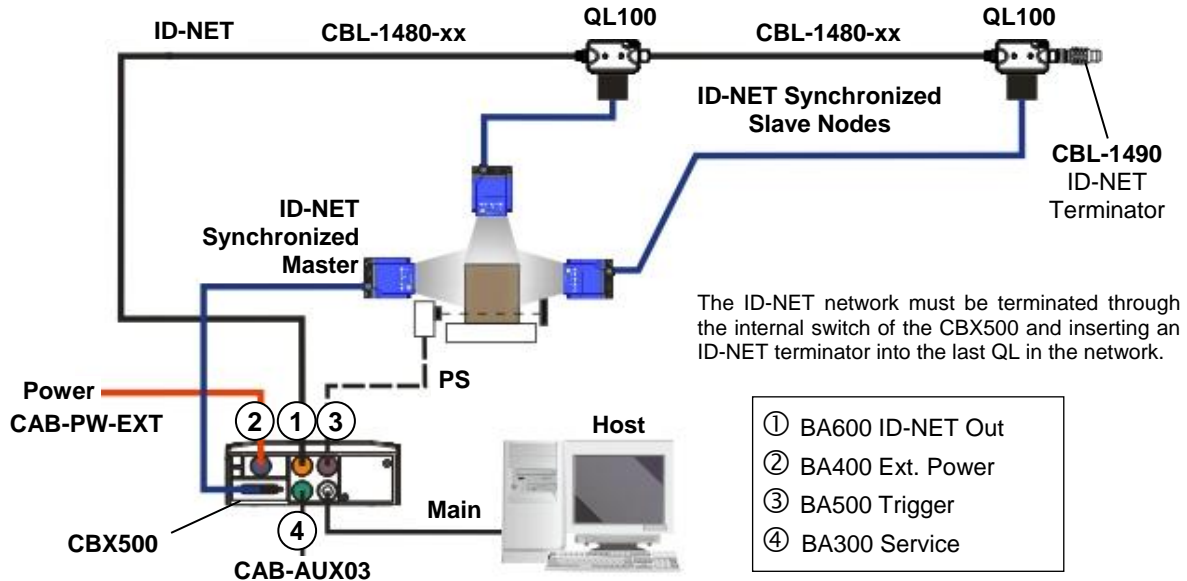

Figure 68 – ID-NET Synchronized Layout

The Master reader can be connected to the CBX series connection box with the advantage of the Backup and Restore configuration function (CBX + BM100 module).

All devices always support multiple output channels (i.e. for data monitoring).



**Figure 69 - ID-NET Synchronized Layout  
Matrix 210N Master with CBX500 + Matrix 210N Slaves with QL100**

If the Backup and Restore function is not required, then a QL300 can be used to connect the master reader.

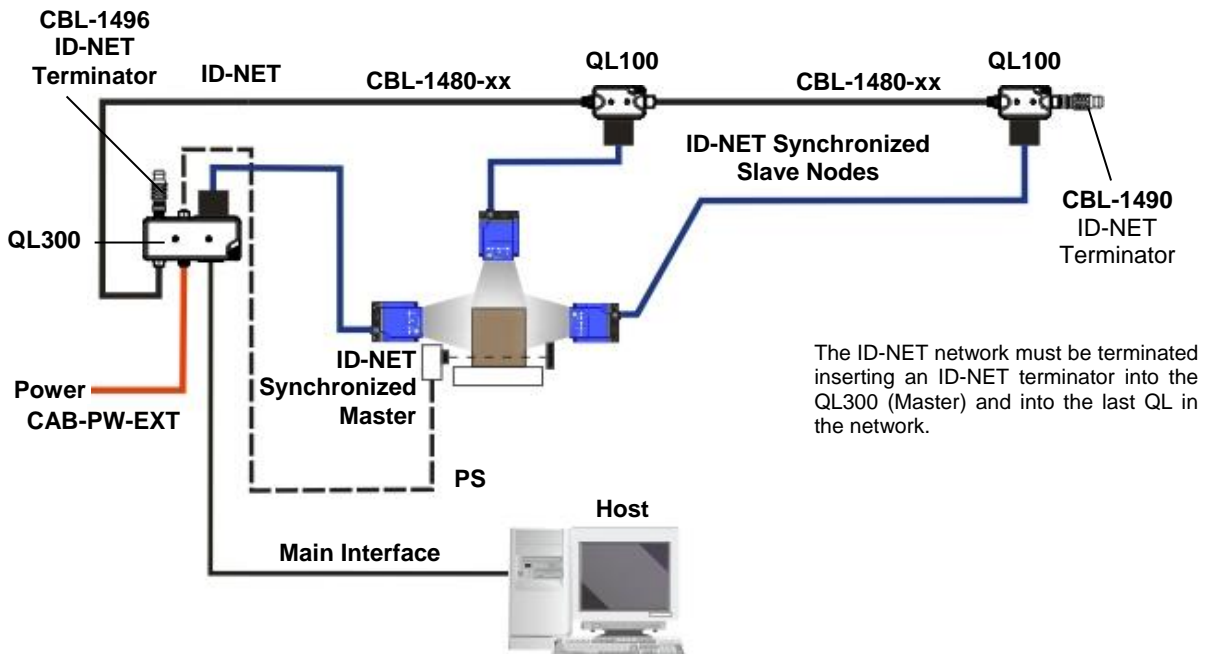

**Figure 70 - ID-NET Synchronized Layout  
Matrix 210N Master with QL300 + Matrix 210N Slaves with QL100**

The same configuration can be made to a Host using the on-board Ethernet interface to the Master. The TCP/IP Ethernet and ID-NET interfaces are connected as shown in the figure below.

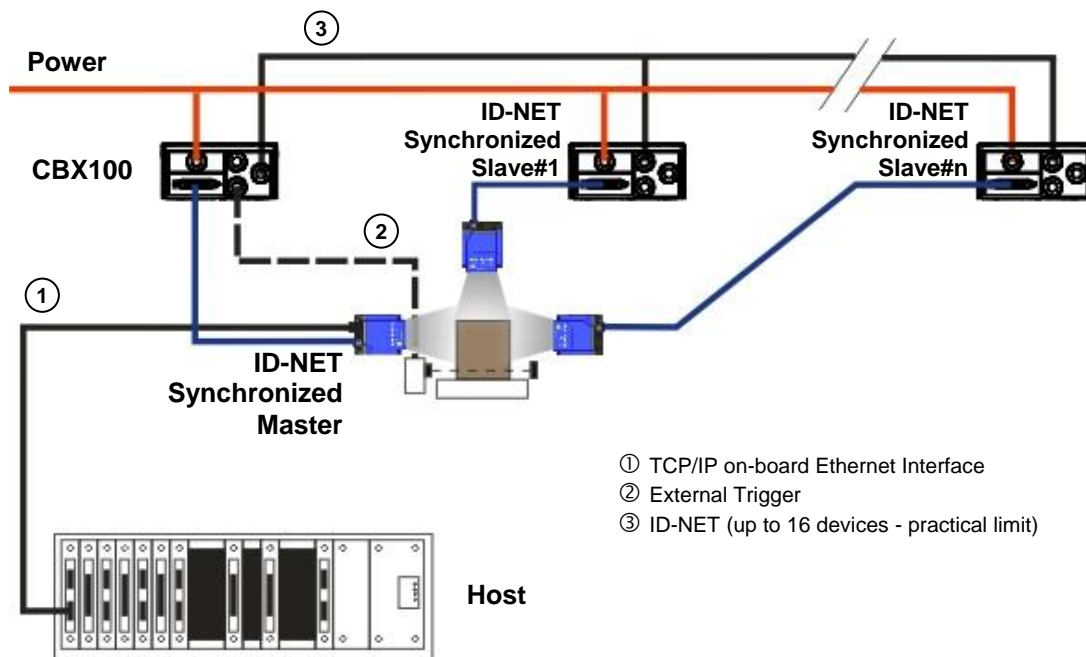

Figure 71 – ID-NET Synchronized Layout with Master on-board TCP/IP Ethernet Interface to Host

Alternatively, the Master reader can communicate to the Host as a Slave node on a Fieldbus network. This requires using an accessory Fieldbus interface board installed inside the CBX500 connection box. System configuration can be accomplished through the Ethernet interface of each individual reader using the DL.CODE configuration program.

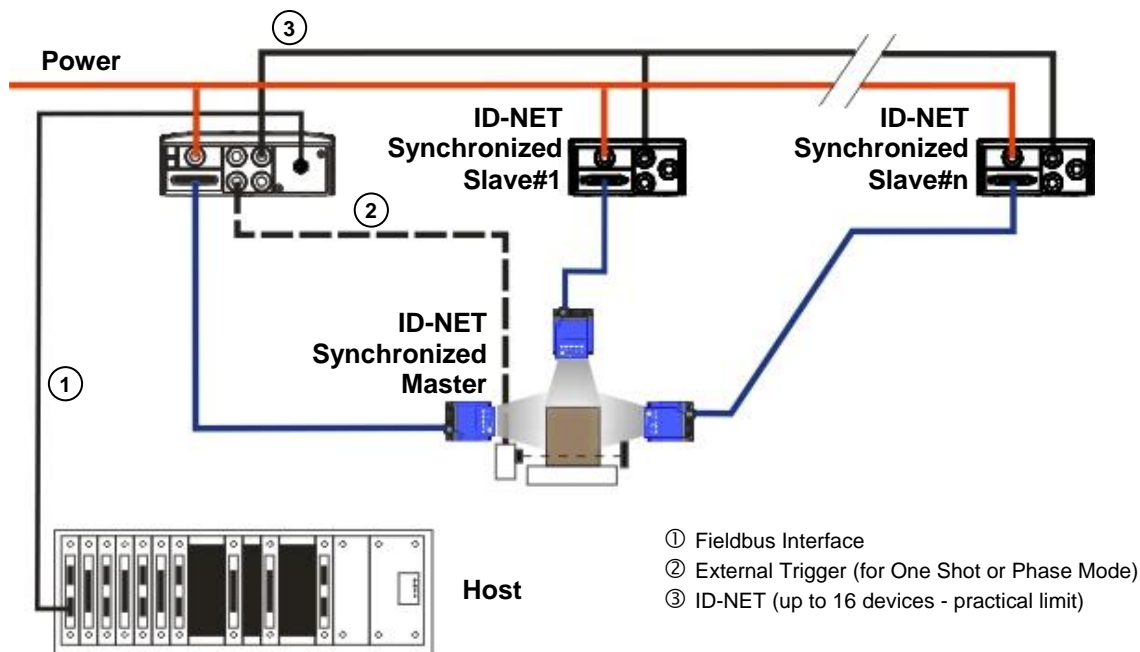

Figure 72 – ID-NET Synchronized Layout with Master CBX500 Fieldbus Interface to Host

## 5.7 USB CONNECTION

Matrix 210N USB models can be connected in a Point-to-Point layout to a local host through their USB cable. No external power supply is necessary.

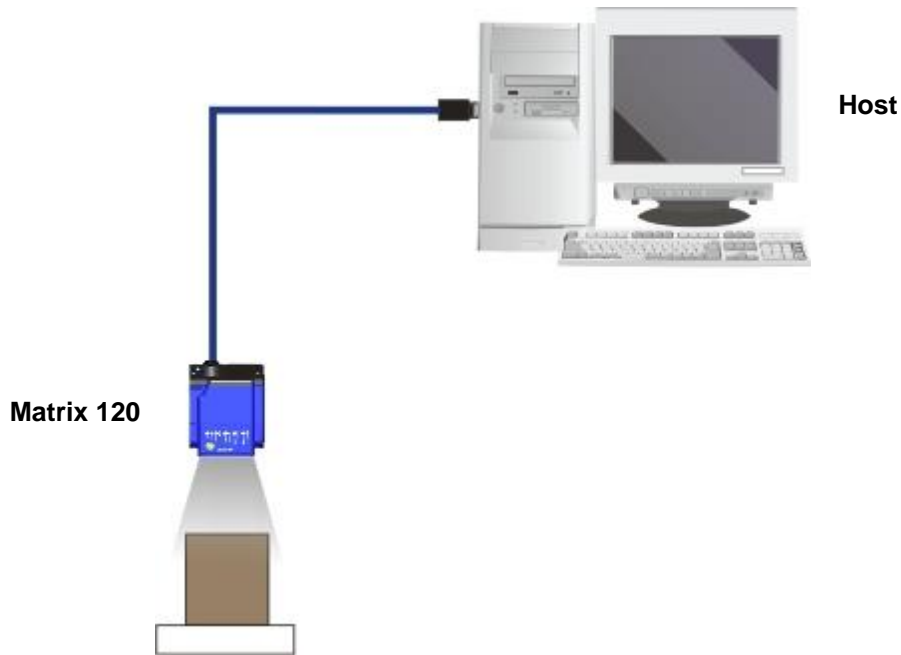

Figure 73 – Matrix 210N USB Point-to-Point Layout

One or more Matrix 210N USB models can be connected to a USB Hub. The HUB must be able to supply 500 mA to each port.

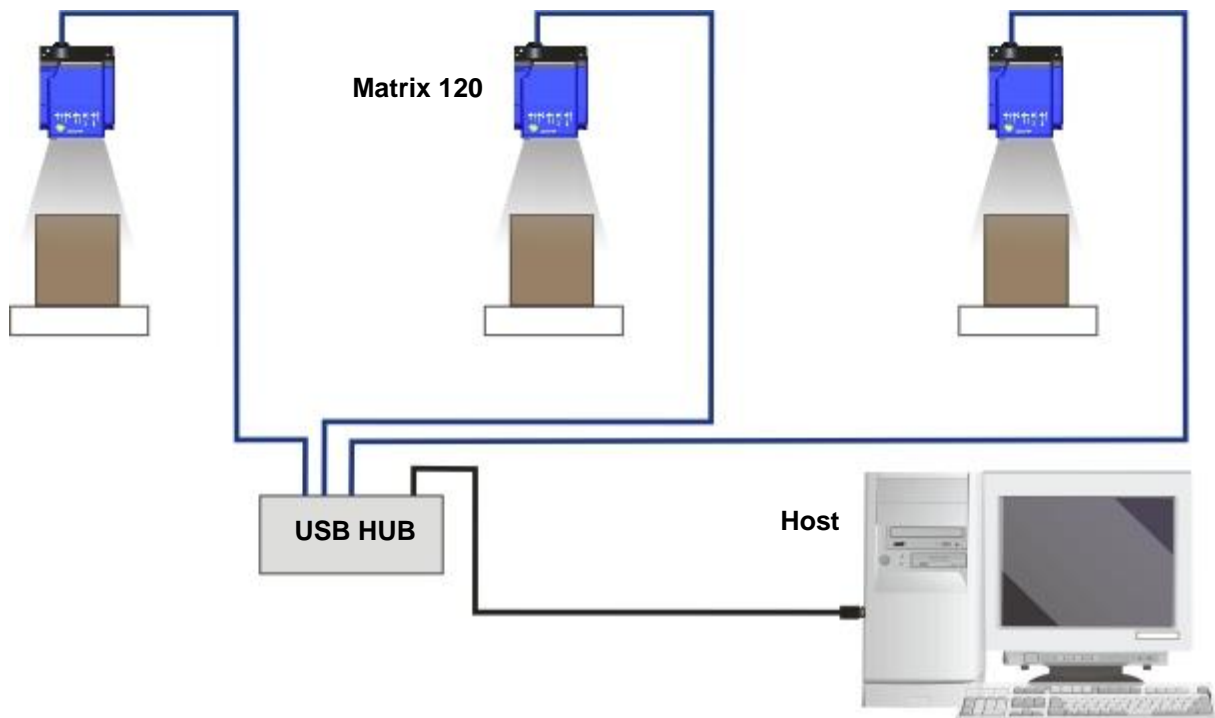

Figure 74 – Matrix 210N USB Layout to HUB

## 6 READING FEATURES

### 6.1 MATRIX FIXED FOCUS MODELS

MODELS	Focus Distance mm (in)	Field of View <sup>(1)</sup> mm (in)	PPI <sup>(2)</sup>	Typ. Linear and Stacked Code Resolution mm (mils)	2D Code Resolution mm (mils)	Reading Distance <sup>(3)</sup> mm (in)	
						min.	max.
211-xxx NEAR	45 (1.77)	35 × 22 (1.38 × 0.87)	545	0.10 (4)	Max. 0.13 (5)	42 (1.65)	53 (2.08)
					Typ. <b>0.19 (7.5)</b>	<b>36 (1.42)</b>	<b>61 (2.40)</b>
212-xxx MEDIUM	65 (2.56)	50 × 32 (1.97 × 1.26)	380	0.15 (6)	Max. 0.19 (7.5)	54 (2.13)	90 (3.54)
					Typ. <b>0.25 (10)</b>	<b>47 (1.85)</b>	<b>101 (3.97)</b>
213-xxx FAR	105 (4.13)	80 × 50 (3.15 × 1.97)	238	0.20 (8)	Max. 0.25 (10)	85 (3.35)	135 (5.31)
					Typ. <b>0.38 (15)</b>	<b>70 (2.76)</b>	<b>192 (7.55)</b>

<sup>(1)</sup> @ Focus Distance

<sup>(2)</sup> Pixels per inch @ Focus Distance

<sup>(3)</sup> Measurement Conditions:

- Test Chart: provided with the reader
- Still code at the center of the FOV
- Code Symbology: Data Matrix ECC 200
- Tilt Angle: 45°
- Skew Angle: 15°
- Code Contrast = *Low* \*
- Decoding Complexity = *Very High* \*

\* These parameter settings can increase the image processing time.

All distances are measured from the reading window to the code surface.

Depending on the code resolution, symbology and number of characters in the code, the Reading Area can be different from the FOV.

## 6.2 FOV CALCULATION

Use the data in the following table to calculate the FOV for your application, referring to Figure 75 and the formula below.

Model	Lens Focus Type	$d_0$	Viewing Angle Horizontal	Viewing Angle Vertical	Viewing Angle Diagonal	Min Reading Distance mm
Matrix 210 2x5-xxx	7 mm software	14 mm	35°	23°	41°	40

The viewing angle has a tolerance of  $\pm 1^\circ$  depending on the reading distance.

$$FOV_x = 2 \left[ (d + d_0) \tan (\alpha_x/2) \right]$$

where:

$FOV_x$  = horizontal, vertical or diagonal FOV

$\alpha_x$  = horizontal, vertical or diagonal viewing angles.

$d$  = reading distance (from window surface to code surface)

$d_0$  = offset (from center of lens to window surface)

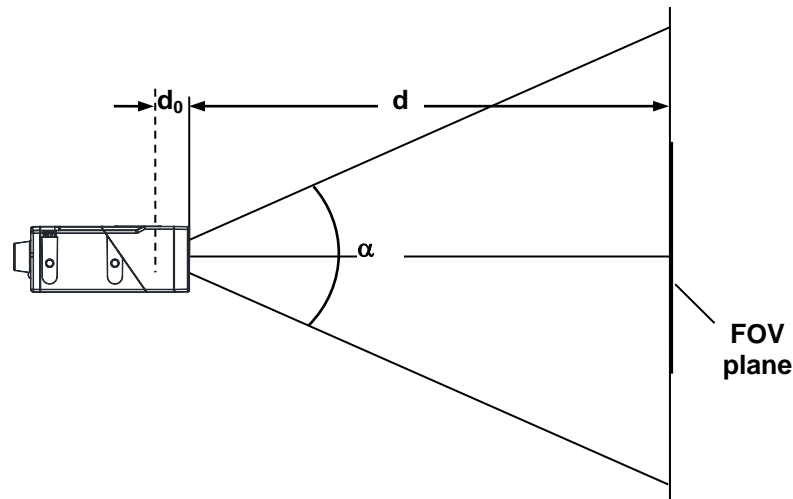

Figure 75 – Reading Distance References

### Example:

The FOV for a **Matrix 210 225-111** at a **reading distance of 120 mm** is:

$$FOV_H = 2 \left[ (120 \text{ mm} + 14 \text{ mm}) \tan (35^\circ/2) \right] \cong 85 \text{ mm}$$

$$FOV_V = 2 \left[ (120 \text{ mm} + 14 \text{ mm}) \tan (23^\circ/2) \right] \cong 55 \text{ mm}$$



### 6.3 GLOBAL FOV DIAGRAMS



**NOTE:** The following diagrams are given for typical performance at 25°C using high quality grade A symbols according to ISO/IEC 15416 (1D code) and ISO/IEC 15415 (2D code) print quality test specifications. Testing should be performed with actual application codes in order to maximize the application performance.

The following diagrams show the **maximum obtainable** Field of View for 1D and 2D codes using Processing Mode = Advanced. **Depending on the code resolution, symbology, and number of characters in the code, the Reading Area can be different from the FOV.**

### 6.3.1 Software Adjustable Focus Models

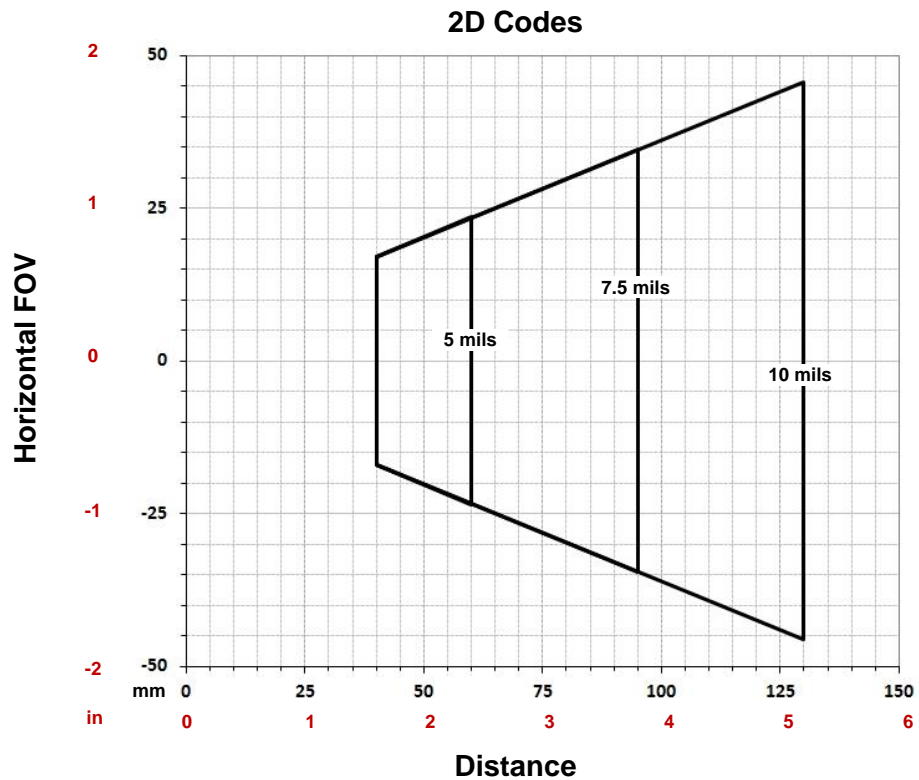
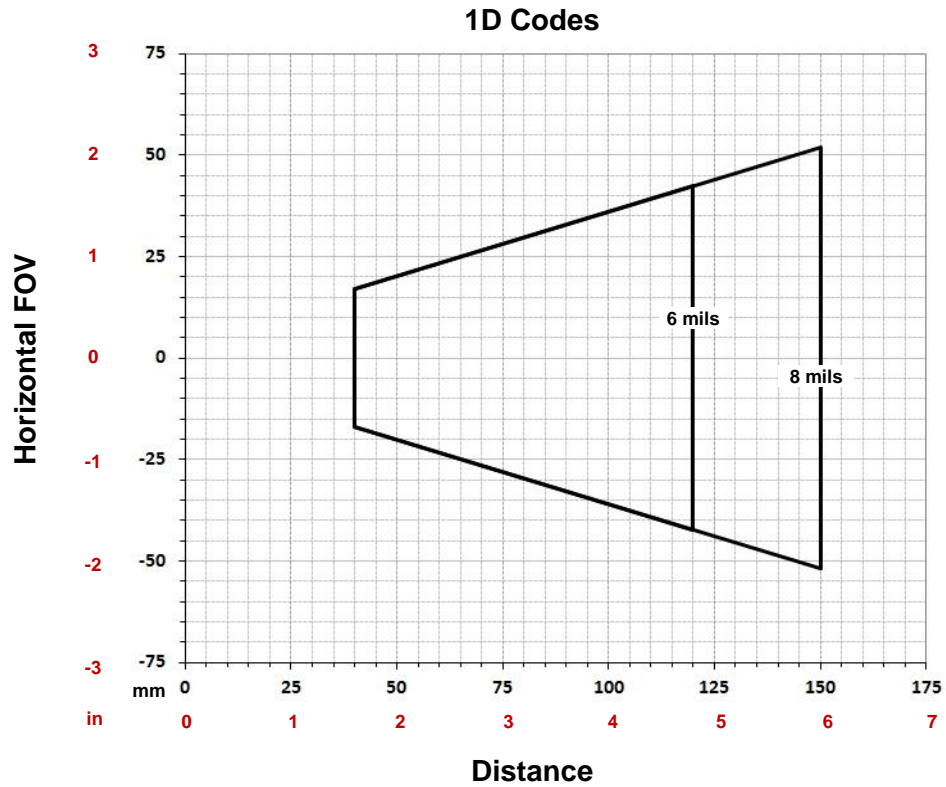

## 6.4 MAXIMUM LINE SPEED CALCULATION

The **Exposure Time** (or **Shutter**) parameter defines the time during which the image will be exposed to the reader sensor to be acquired. This parameter depends heavily on the environmental conditions (external lighting, image contrast etc.).

In general, a longer time corresponds to a lighter image but is susceptible to blurring due to the code movement; a shorter exposure time corresponds to a darker image.



**NOTE:** The following considerations must be applied only when the internal lighting system and **2D codes** are used. The Maximum line speed allowed for linear codes or postal code reading applications heavily depends on the direction of symbol movement. When the direction of movement is parallel to the elements of the code, the maximum speed is greater.

Assuming:

- **X:** Code Resolution (mm)
- **T<sub>exp</sub>:** Exposure Time (s)
- **LS:** Line Speed (mm/s)

The essential condition to avoid blurring effects between two adjacent elements in a dynamic reading application is:

$$LS \times T_{exp} \leq X$$

The maximum (theoretical) line speed (LS) can be calculated as follows:

$$X / T_{exp (min)} = LS_{(max)}$$

**T<sub>exp (min)</sub>** is the minimum **Exposure Time** value obtainable for the specific application. It can be evaluated in static reading conditions and may depend on code printing quality, reader position, etc.

Using the formulas previously explained it is possible to calculate the theoretical maximum line (target) speed expected for the application, based on the maximum code resolution and the minimum suitable **Exposure Time** value.

The minimum **Exposure Time** value depends on the reading distance and on external lighting.

The maximum target speed in the application is also affected by these conditions:

- **Code/Background Contrast:** maximum speed decreases when decreasing image contrast (poor quality codes, reflective transparent coverings, different supports and printing techniques).
- **Code Resolution:** maximum speed increases when decreasing code resolution (there is a decrement of overlapping effects between two adjacent elements).
- **Tilt Angle:** maximum speed decreases when increasing Tilt angle (from 0 to 45 degrees).

The **Internal Lighting** parameter allows setting the operating mode of the internal lighting system. The possible values are:

- *Disabled:* the built-in lighting system is turned off all the time. This option can be useful only if external lighting is sufficient;
- *Always ON:* the built-in lighting system is turned on all the time at the lowest power level. This option is useful if the lighting system blinking (Strobed operating mode) disturbs the operator.
- *-Power Strobed:* the built-in lighting system is on only during the image exposure time. Different Power Strobed lighting levels can be set.



**NOTE:** To avoid LED array overheating, for Power Strobed settings, the program automatically limits the range of allowed values for the **Exposure Time** parameter. Therefore, after changes to **Internal Lighting**, recheck **Exposure Time**.

## 7 SOFTWARE CONFIGURATION

---

Software configuration of your Matrix 210N for static reading or simple code reading applications can be accomplished by the Rapid Configuration procedure using the X-PRESS HMI (which requires no external configuration program). This procedure is described in chapter 1 Steps 3-4.

For the majority of applications however you will use DL.CODE, connecting to the reader through the on-board Ethernet interface. See chapter 1 Steps 5-6.

### 7.1 DL.CODE SYSTEM REQUIREMENTS



**CAUTION:** DL.CODE does not currently support Windows Embedded (often used in industrial PCs and/or PLCs).

To install and run DL.CODE you should have a Laptop or PC that meets or exceeds the following:

- 2.00 GHz or faster microprocessor
- Windows: XP SP3, 7, 8, or 10
- 1 GB RAM
- 2 GB hard disk for 64-bit machines; 1 GB hard disk for 32-bit machines
- 100 Base-T Ethernet
- One 19" or larger monitor (optimized for 1280x1024 resolution)

### 7.2 READER CONFIGURATION

For an example of Matrix device configuration see the example in chapter 1 Steps 5-6.



**NOTE:** Especially for lengthy configurations, it is always good practice to periodically save the configuration to permanent memory (**Save on Device**)



to avoid losing the configuration in Temporary Memory. You must give a name to the new configuration or overwrite an existing one (except for Default which cannot be modified).

When all the configuration parameters are set correctly and saved to the device, you can perform a Backup to File and/or to an External storage device (BM100, etc.). See par. 7.5.



**NOTE:** An improvement in the Matrix N Family readers allows them to contain several configurations or jobs in permanent memory.

This means that in addition to your application configuration(s), the Default configuration is always present on the reader and in fact it is not modifiable and cannot be deleted.

## 7.2.1 Auto Calibration

DL.CODE provides the **Image Auto-Setup** tool to maximize the reading performance by tuning the acquisition parameters (photometry) automatically. By selecting the **Image Auto-Setup** tool from the Image Settings branch in the Advanced Setup step, the following window appears:

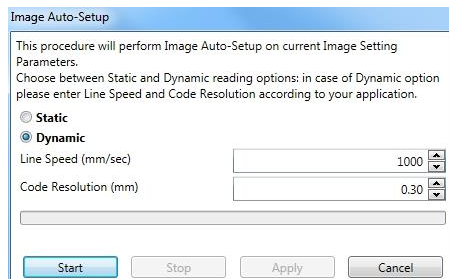

Figure 76 – Image Auto-Setup

Select the Static or Dynamic Self-Tuning option; Start Image Auto-Setup and Apply to the Image Settings. The Advanced Setup window works interactively so that you can see the results of the parameter setting changes as well as the decoding results (Results panel).

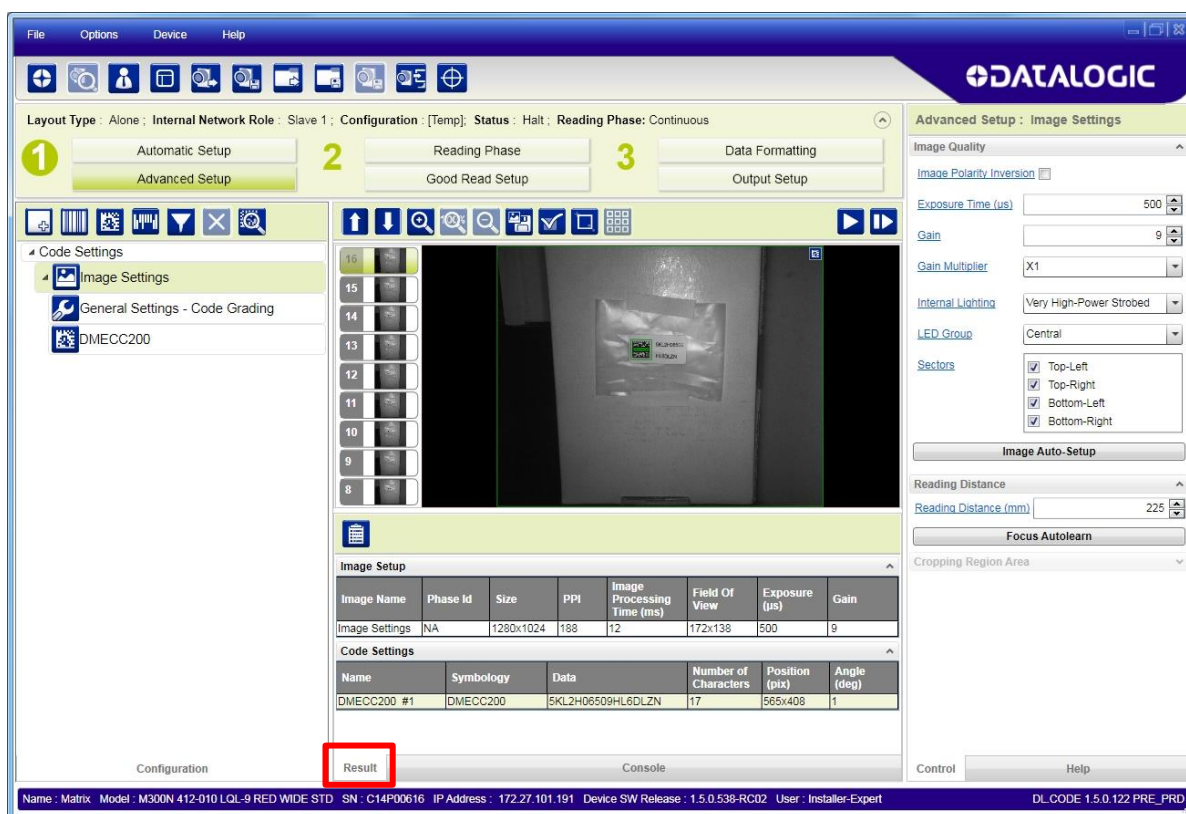

Figure 77 – Decoding Results OK

## 7.2.2 Manual Calibration

The following examples show some of the typical conditions occurring during the installation and how they can be tuned manually:

### Under-exposure:

To correct this result it is recommended to change the following parameters in their order of appearance:

1. increase the **Exposure Time**
2. increase the **Gain**



**NOTE:** In general, a longer exposure time corresponds to a lighter image but is susceptible to blurring due to code movement. Exposure time is also limited by the Internal Lighting mode parameter. **Longer exposure times can be set if the power strobe level is lowered.**

High gain settings may produce a grainy image that may affect the decoding process.

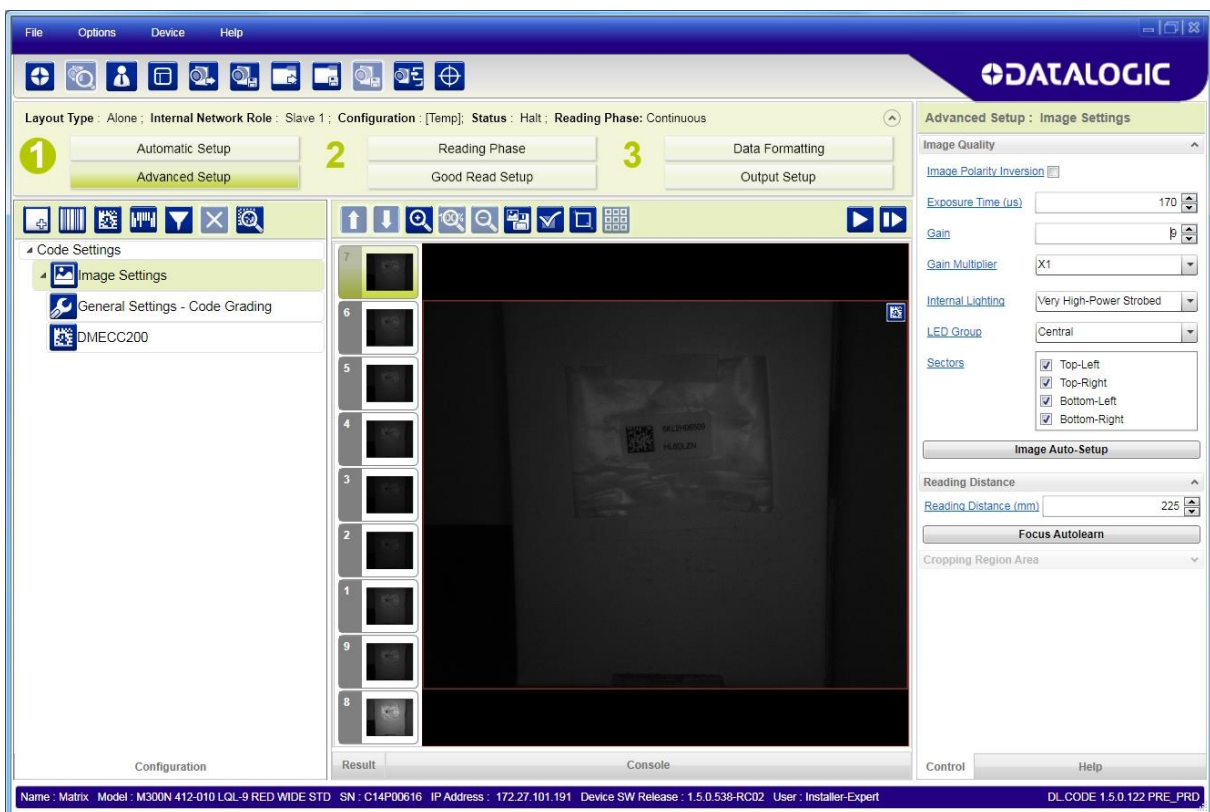

Figure 78 - Example Under Exposure: Too Dark

## Over-exposure:

To correct this result it is recommended to change the following parameters in their order of appearance:

1. decrease the **Gain**
2. decrease the **Exposure Time**

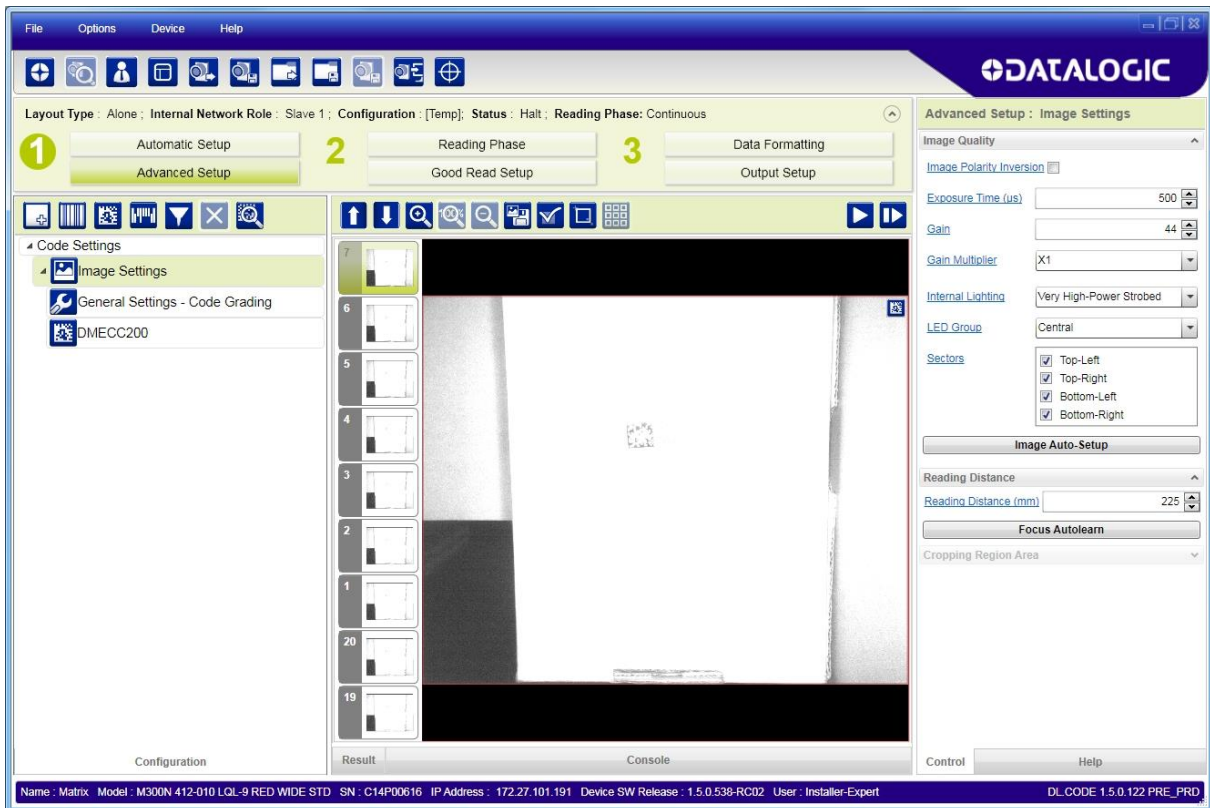

Figure 79 - Example Over Exposure: Too Light

## Moving code out of the Field of View:

To correct this result and have the code completely visible in FOV, it is possible to follow one or both the procedures listed below:

- reposition the reader
- use the **Delay on Trigger** and set the **Time** or **Space** values.



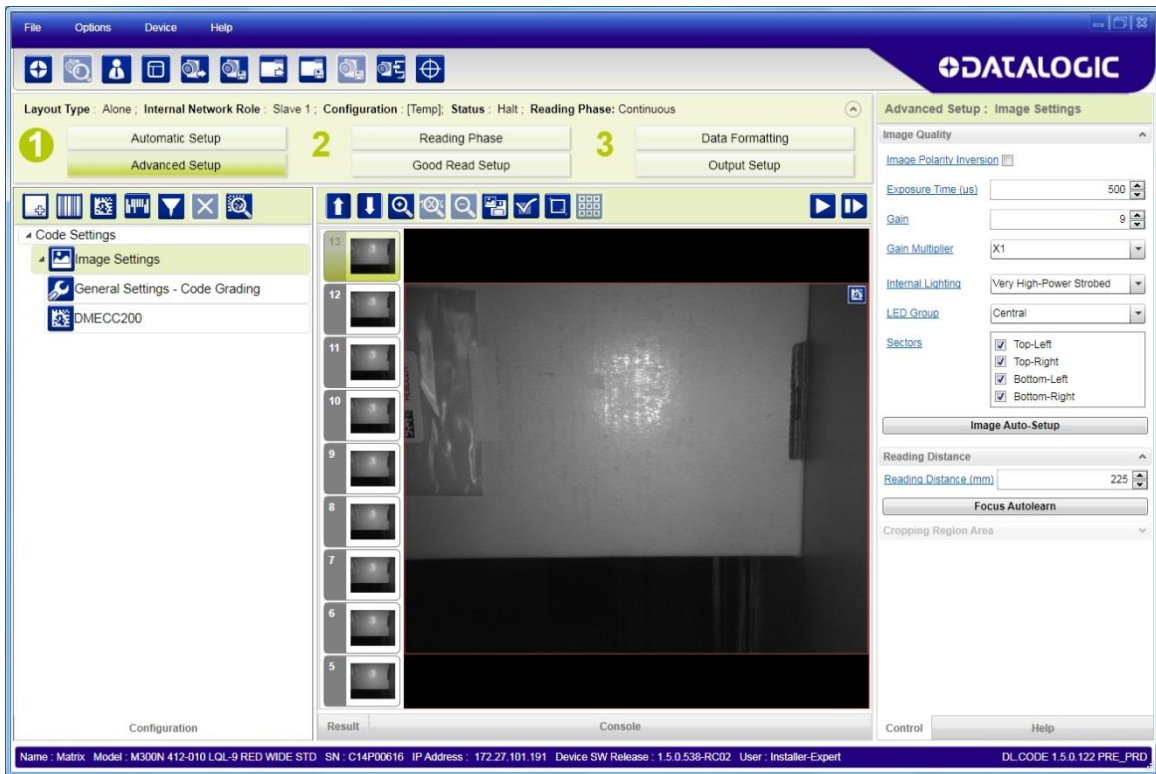

Figure 80 - Example Out of FOV

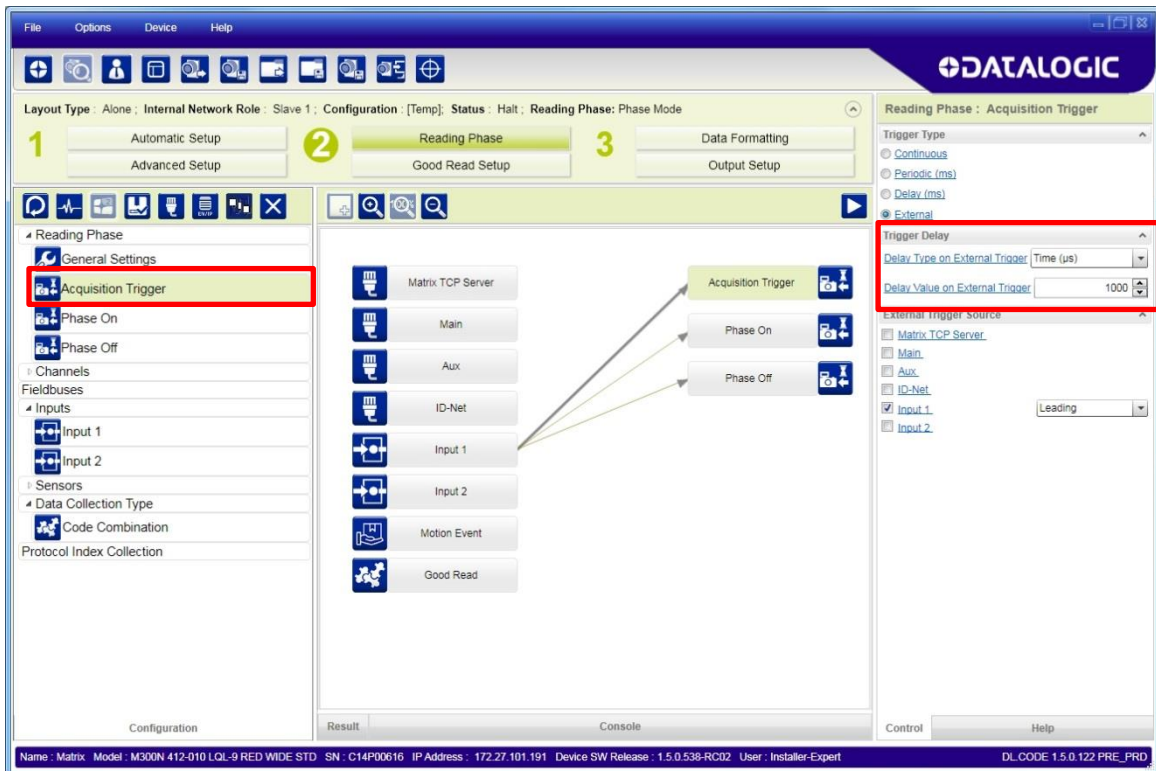



Figure 81 – Add Delay on Trigger to Correct Out of FOV

## 7.2.3 Multi Image Acquisition Settings

When controlled variable conditions occur in the application, Multiple **Image Acquisition Settings** can be defined to create a database of parameter groups that handle each specific application condition. This database of pre-defined settings improves system flexibility and readiness by being applied either automatically or selectively by an activation event.

For example, an application may have several stable but different lighting conditions which require different lighting options. One Image Acquisition Setting could enable and use an internal illuminator and another setting could enable and use an external lighting system.

This feature is available for all Operating Modes.

**Image Settings** are found in the DL.CODE **Advanced Setup** step. Up to 10 different Image Settings can be configured by adding them with the  icon.

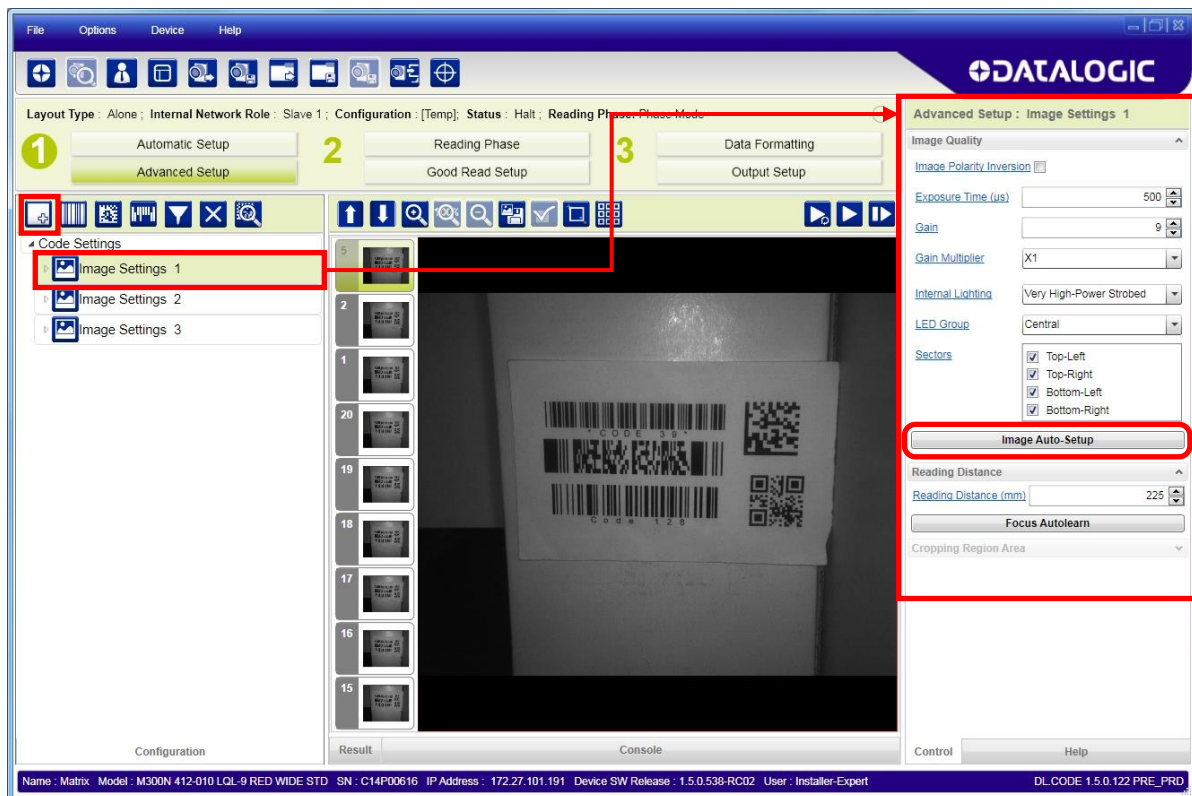

For each Image Setting condition start **Image Auto-Setup**, select the Static or Dynamic Self-Tuning option; and Apply it.

## Automatic Image Settings Selection

If we don't know from one item to the next which reading condition will be presented, we will cycle through the pre-defined database of Image Settings (one per acquisition) in order to automatically capture the correctly lighted image over the course of several acquisitions. When the correct condition is matched, the result should be able to produce a Good Read.

When the **Image Settings Selection** is **Automatic** (default), then these Image Settings groups will be used cyclically.

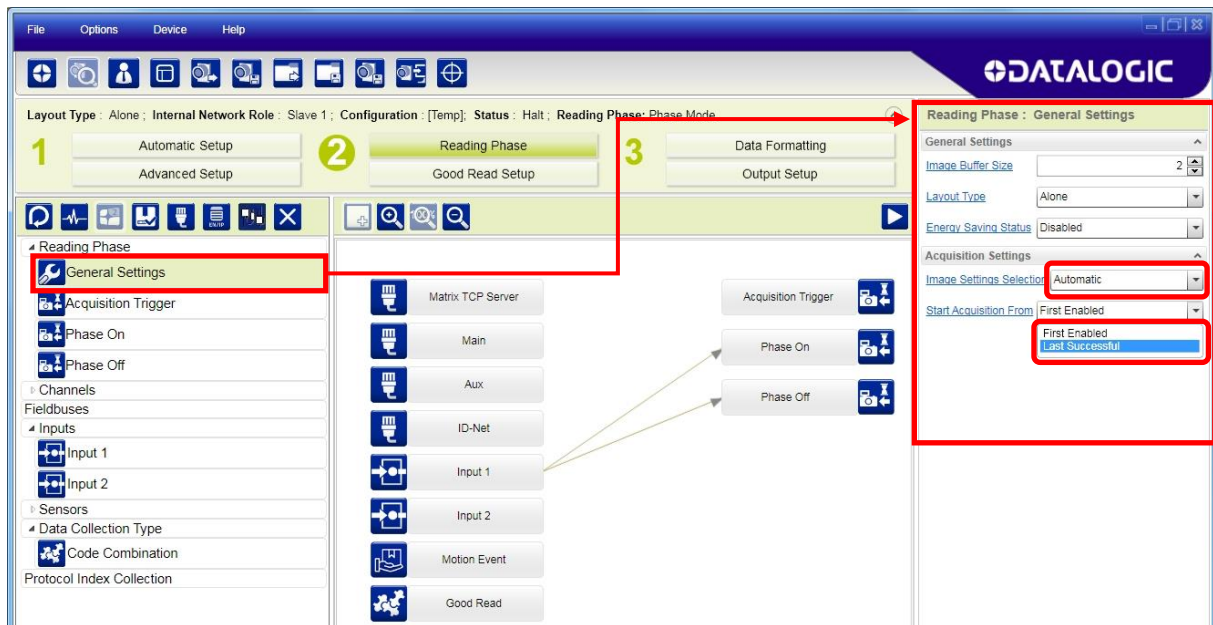

**NOTE:** Applications typically require more than one acquisition to obtain sufficient Good Read percentages. This means that for  $N$  acquisitions we will surely have captured the correct lighting condition but we will also have captured some acquisitions with the wrong lighting condition. A consequence then is that we cannot run these types of applications at the maximum speed because not all the acquisitions are useful to us. We must wait for a sufficient number of acquisitions that will guarantee a Good Read result.

If items to be read having the same lighting conditions are grouped together, then we can improve the read rate through the **Start Acquisition From** parameter. By choosing the **Last Successful** value, we will start with the Image Setting that last produced a Good Read. For this group of items the last Image Setting used will be correct for the next item and so we start each cycle with the acquisition that will potentially produce a Good Read.

## External Image Settings Selection

There are some applications where the lighting conditions are known before each item is read and therefore we can pre-select the correct Image Setting from an external source.

When the **Image Settings Selection** is **External**, Acquisition Sequences are created and by default each Image Setting has its own Acquisition Sequence.

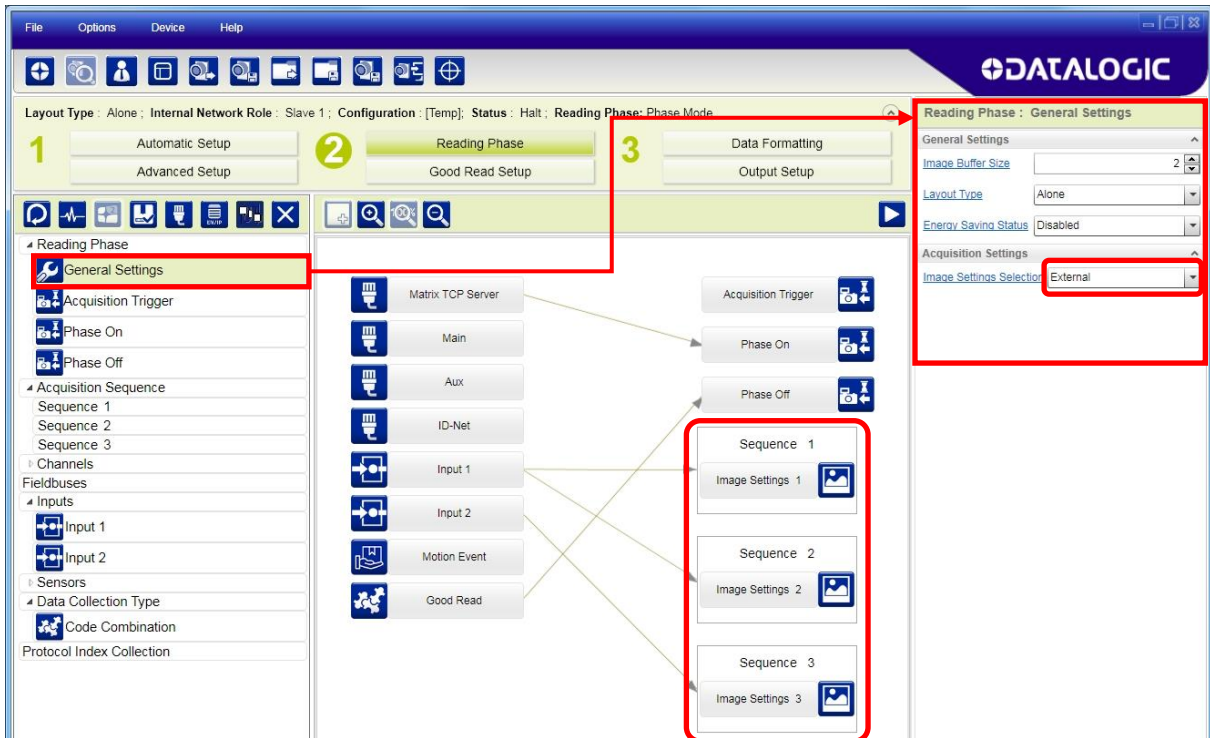

Each **Acquisition Sequence** can be activated exclusively by a single event, either through a string from an available communication channel or by a digital input.

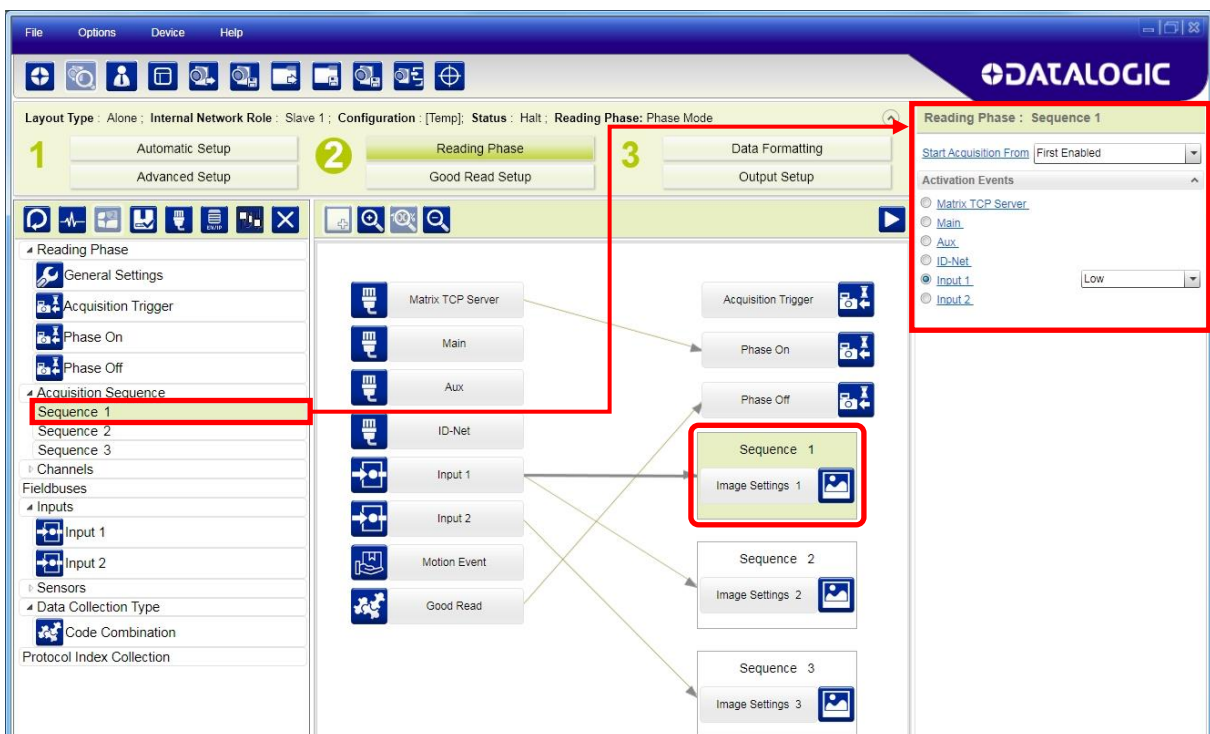

Alternatively a hybrid configuration can be made where more than one **Image Setting** can be grouped into an Acquisition Sequence by dragging it into the desired Sequence box. Select the empty Sequence box and delete it with the delete key.

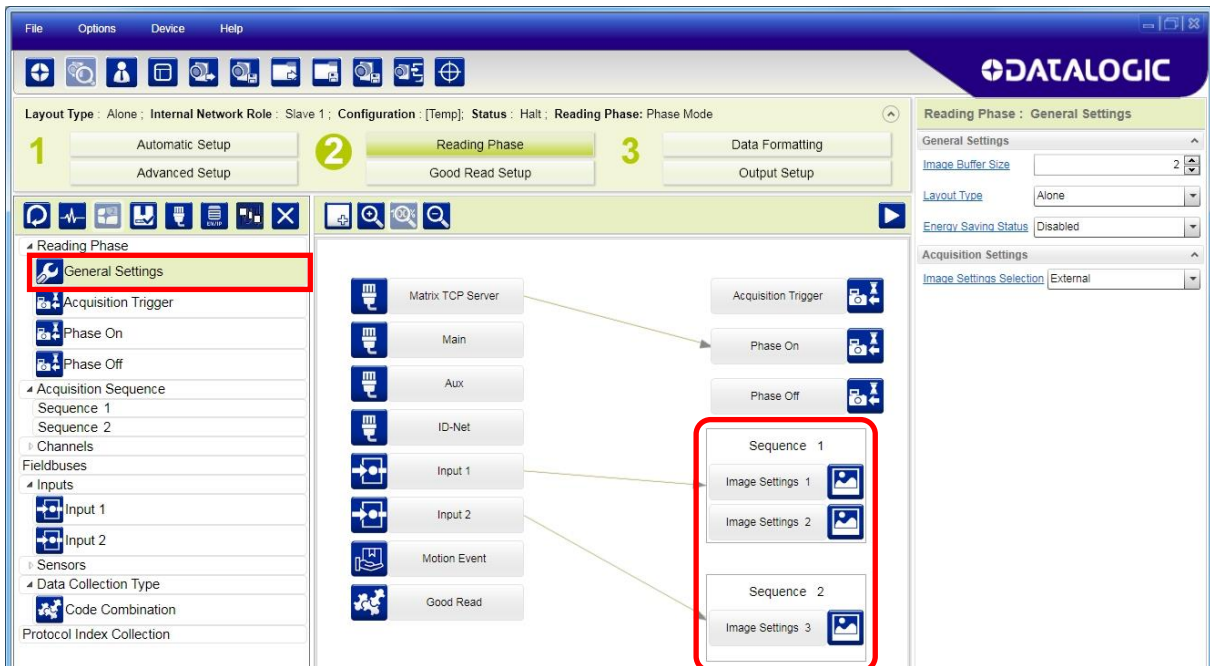

Each **Acquisition Sequence** can be activated exclusively by a single event, either through a string from an available communication channel or by a digital input.

In this case the **Start Acquisition From** parameter can improve the read rate for that Sequence. It has no meaning for a Sequence containing only one Image Setting.

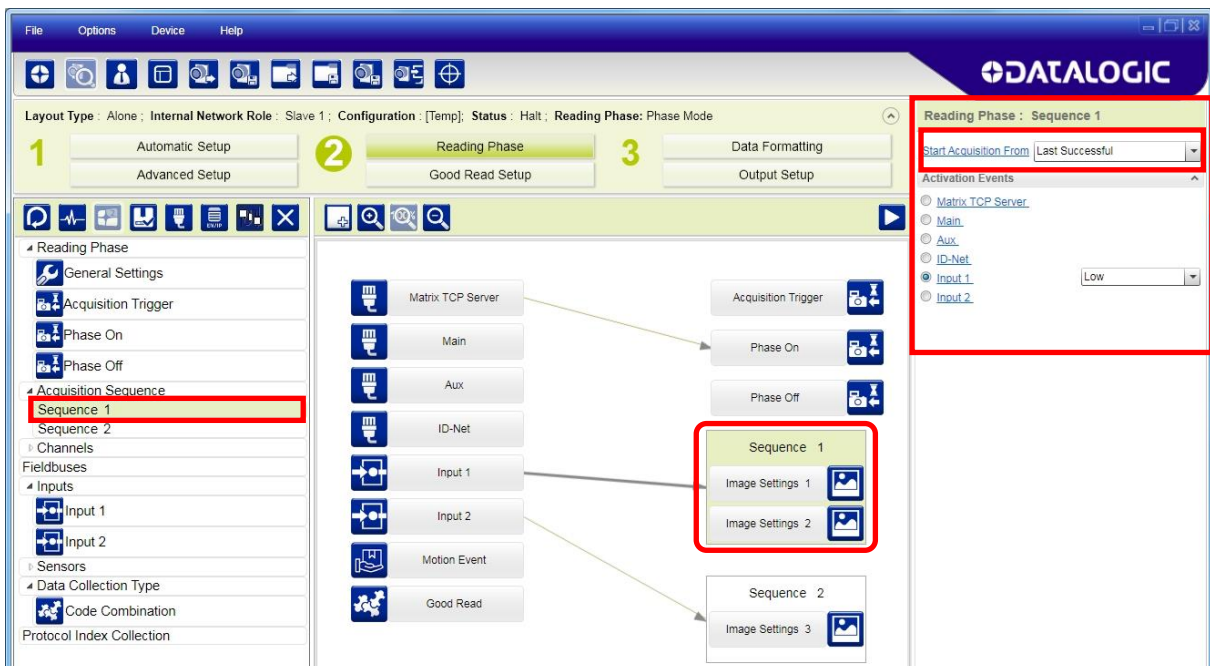

## 7.2.4 Image Cropping

In some applications, the Image Cropping feature in DL.CODE can help to increase decoding and result performance. Image cropping is performed from the Advanced Setup tab by clicking on the Add Cropping Region icon as shown below.

In Matrix 210N the frame rate is dependent on the number of rows and columns in the defined window. Image cropping allows reducing the Image processing area from the full FoV to a smaller area where codes are present. By excluding portions of the FoV, processing time is reduced.

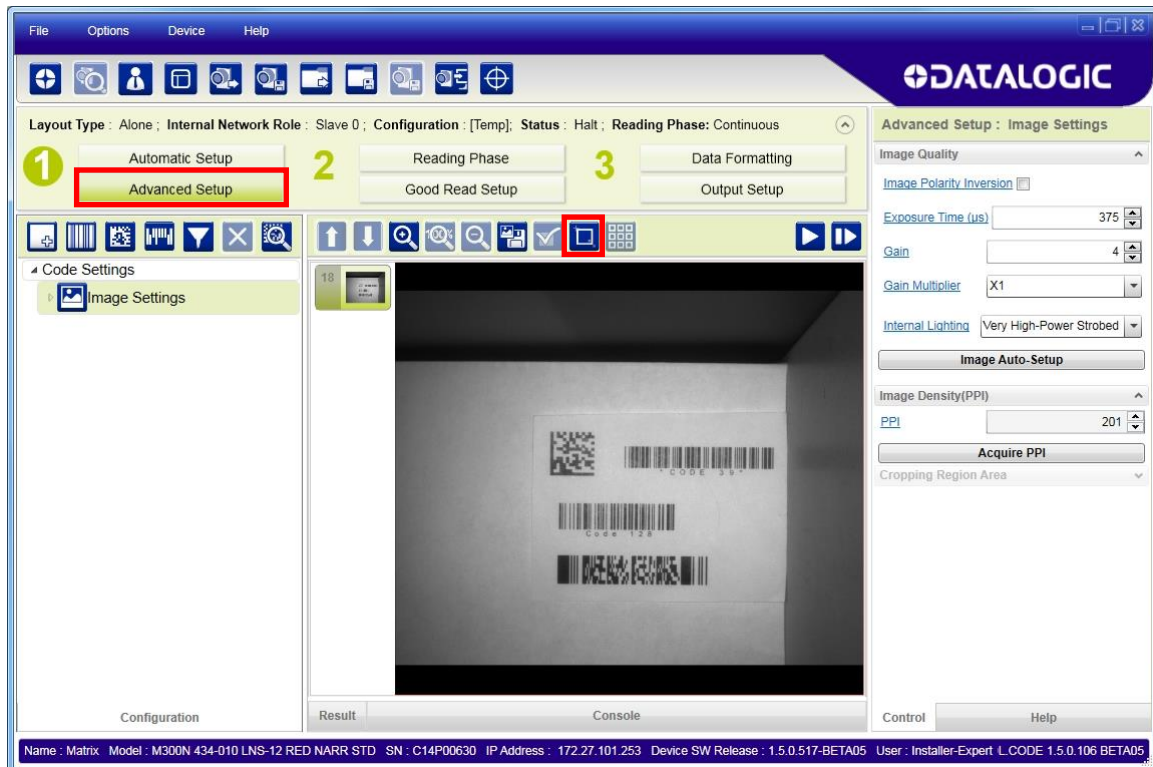

After clicking the Add Cropping Region icon, a blue border appears which by default is equal to the FoV.

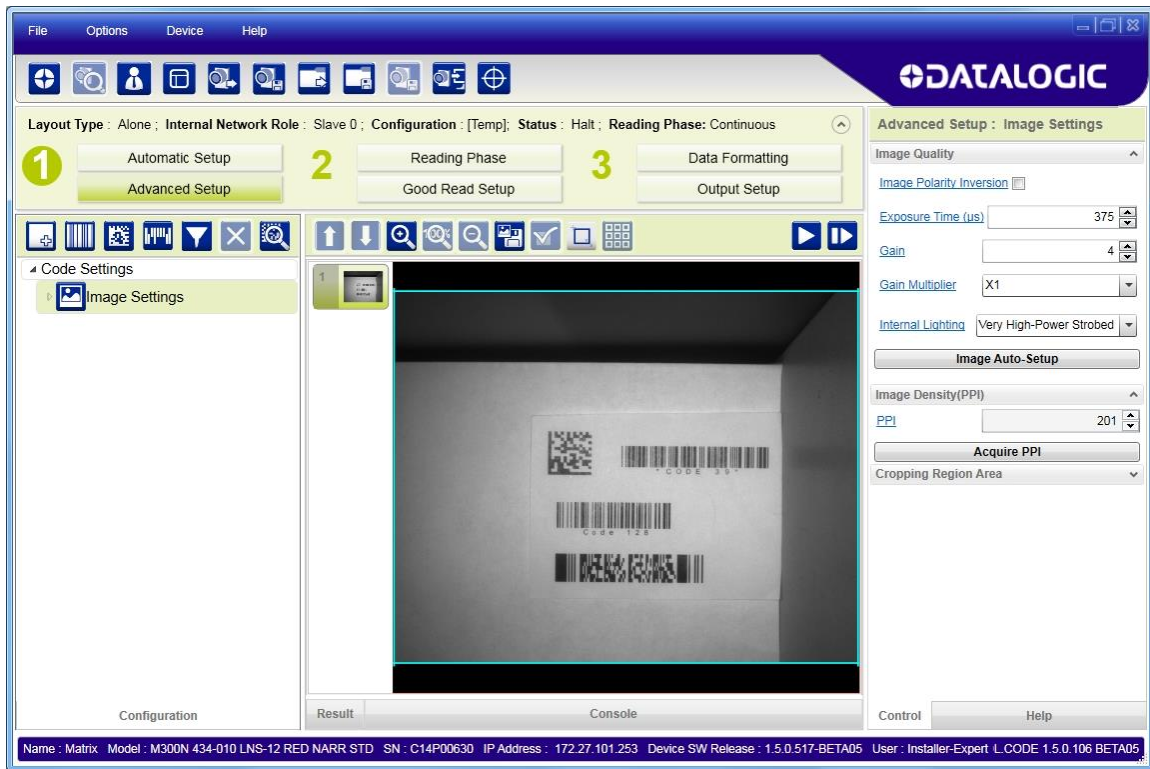

By dragging the edges with the mouse (resizing) you can crop the image to a specific location where codes are present. The numbers in the blue boxes refer to pixel references.

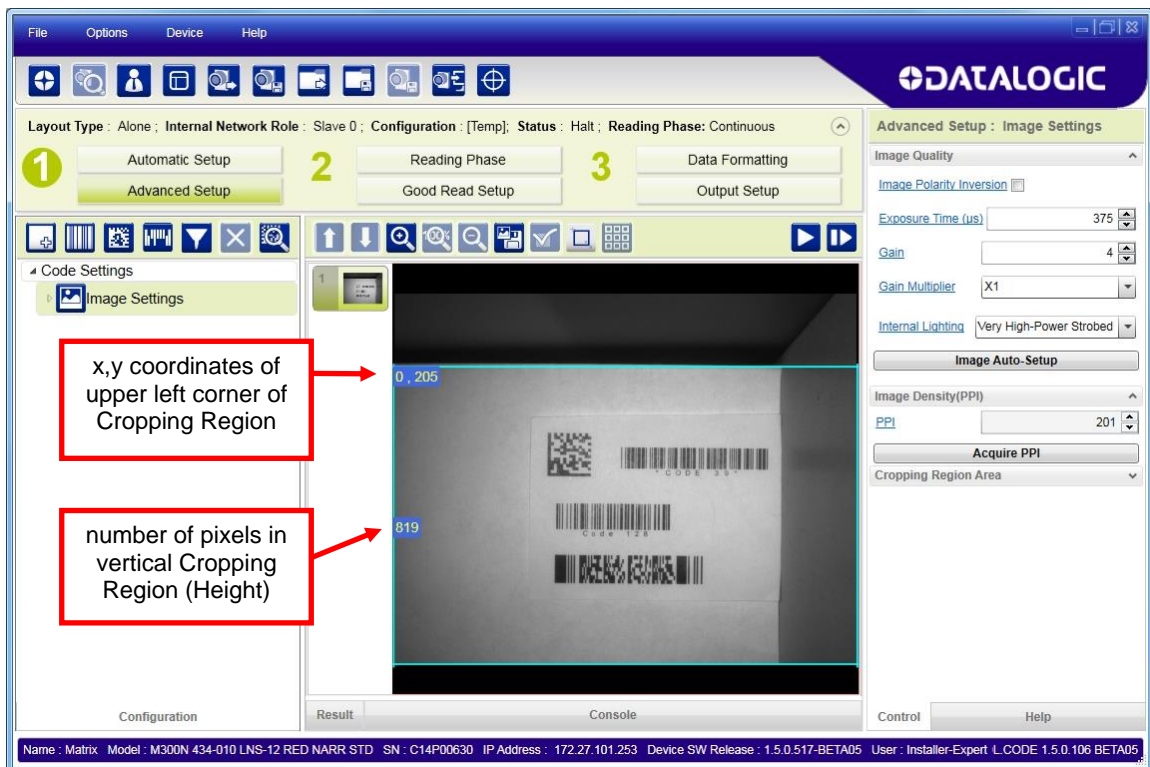

The cropped area can be moved by dragging the center.

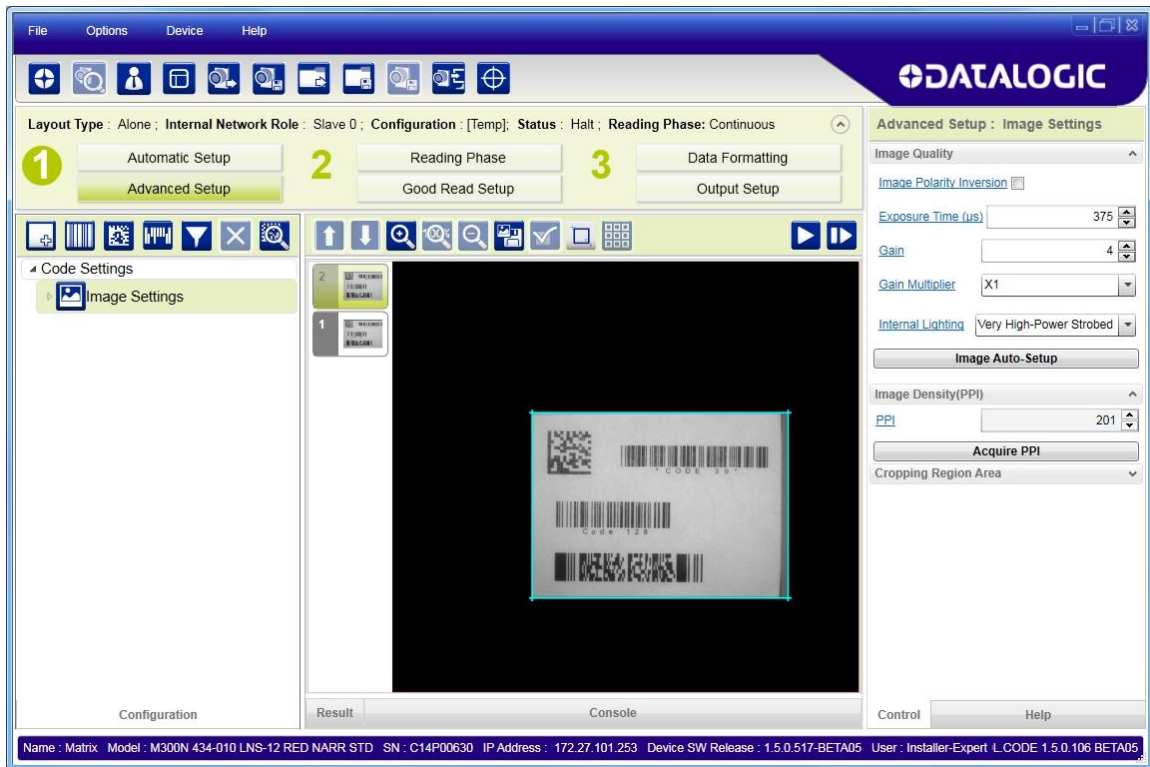

You can also set the cropped image size and position through the Cropping Region Area group of parameters; size = **Width** and **Height**, position = **Left**, **Top** (x,y) coordinates.

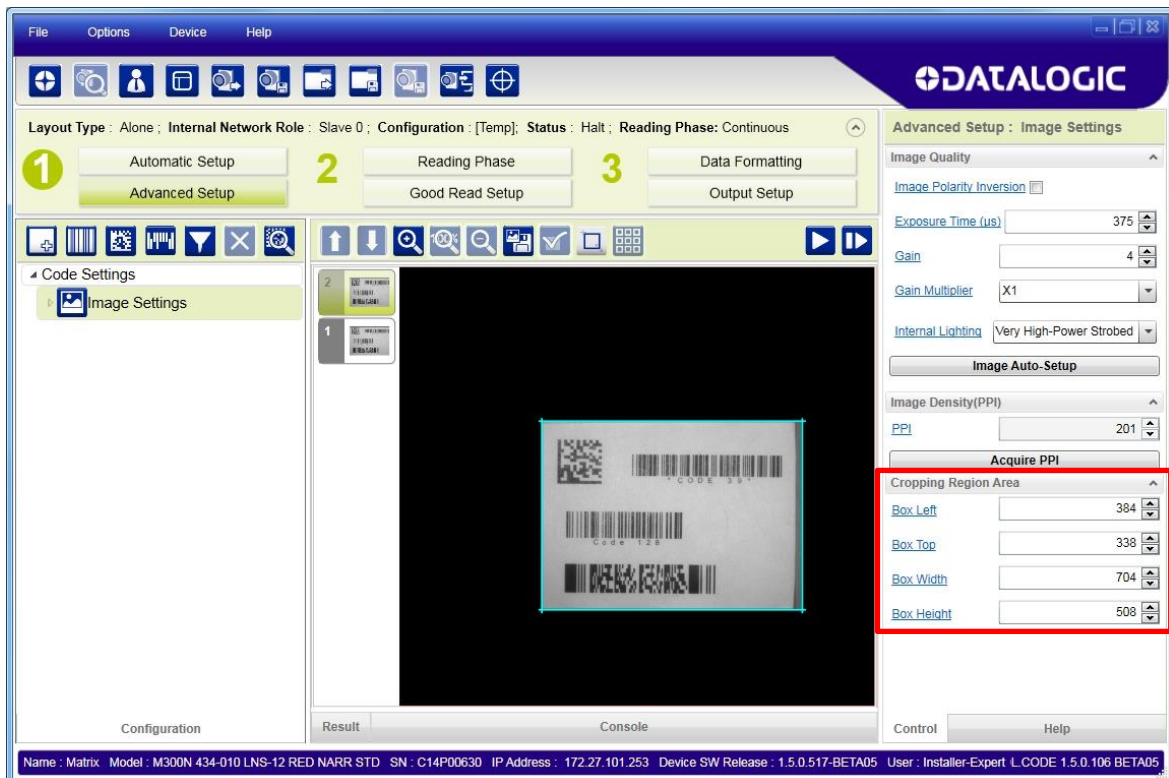



## 7.2.5 Direct Part Marking Applications

For **Data Matrix** family codes the **Decoding Complexity** parameter is available when Processing Mode is set to Standard and selects the decoding algorithm according to the printing/marking technique used to create the symbol and on the overall printing/marking quality.

The possible selections progress from Low to Very High where Low can improve decoding time for good print/mark quality and/or relatively normal size codes. This is the default setting. Very High can improve the decode rate for low print/mark quality and/or small size codes. This algorithm is much more aggressive but in general it may have longer decoding times than the lower complexity algorithms. **To minimize decoding time it is better to select the lowest value that still guarantees good decoding.**

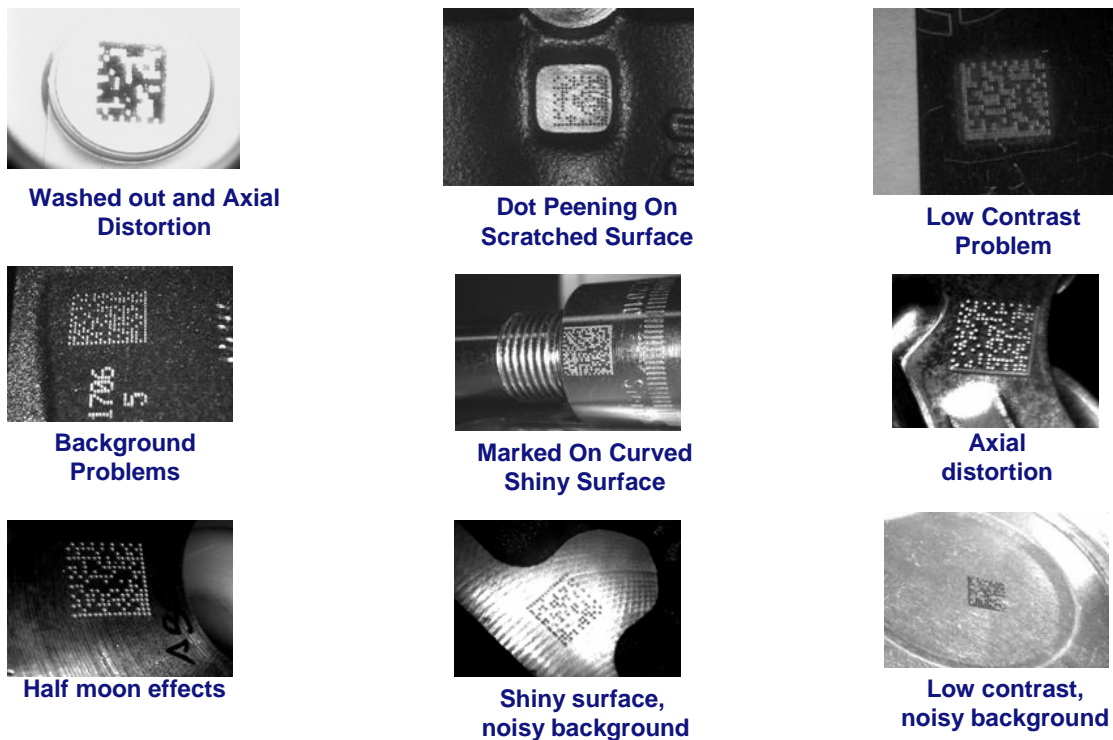

Figure 82 – Problematic Direct Part Marking Examples

For **QR** code the **Decoding Method** parameter allows the Dot Peen Decoding algorithm to be selected which improves the decode rate for low quality Direct Part Mark codes and in general for Direct Part Mark codes with dot peening type module shapes.

## Image Filter

Sets the filter to be applied to the image before being processed. This parameter can be used to successfully decode particular ink-spread printed codes (ex. direct part mark codes).

Different filters can be applied to a single code or group of codes in one or more **Image Settings**. See the DL.CODE User's Manual for examples of Image Filter application.

The **Erode** Filter enlarges the image dark zones to increase readability.

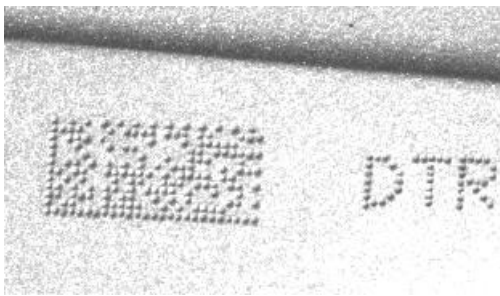

Before - No Read



After - Readable

### Erode

The **Dilate** Filter enlarges the image white zones to increase readability.



Before - No Read



After - Readable

### Dilate

The **Close** filter eliminates dark areas (defects) in the white zones of the image.

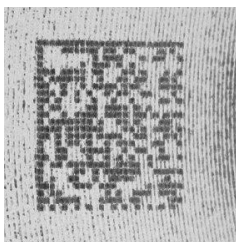

Before - No Read

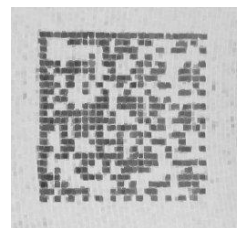

After - Readable

### Close

The **Open** filter eliminates white areas (defects) in the dark zones of the image.

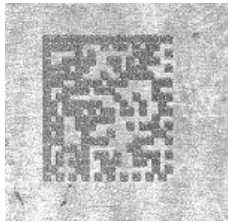

Before - No Read

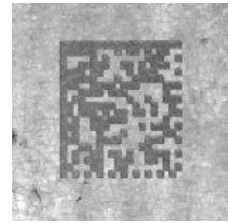

After - Readable

### Open

The **Contrast Stretching** filter maximizes image contrast.

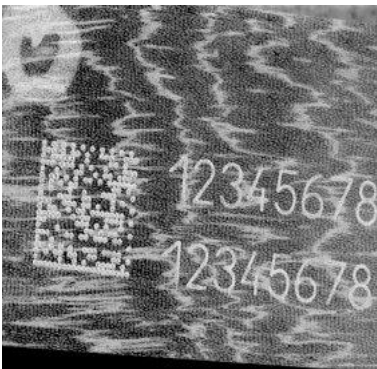

Before - No Read

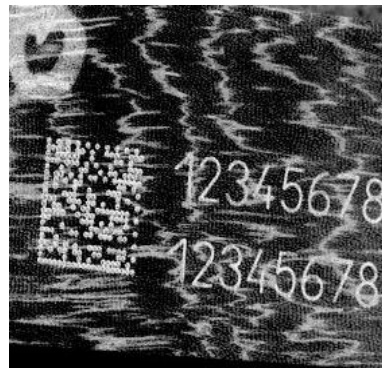

After - Readable

### Contrast Stretching

The ***Histogram Equalization*** filter makes the gray level distribution uniform.



Before - No Read



After - Readable

### Histogram Equalization

The ***Smoothing*** filter deletes small (insignificant) details in the center of the image.

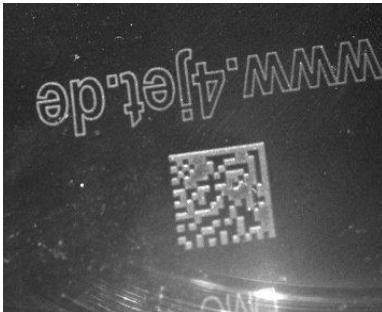

Before - No Read



After - Readable

### Smoothing

The ***Sharpening*** filter improves out of focus images.

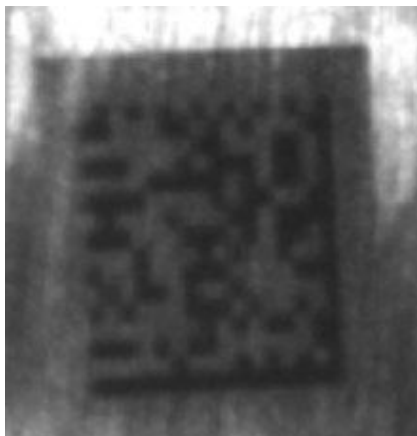

Before - No Read

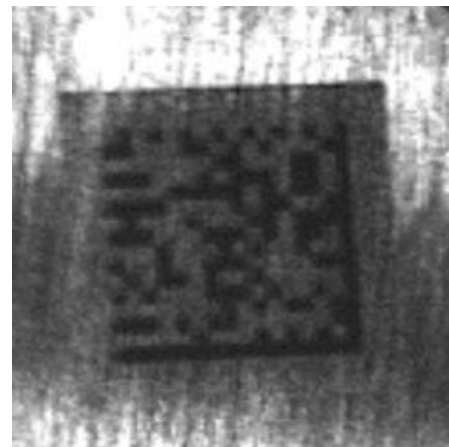

After - Readable

### Sharpening

The **Deblurring** filter improves blurred images.

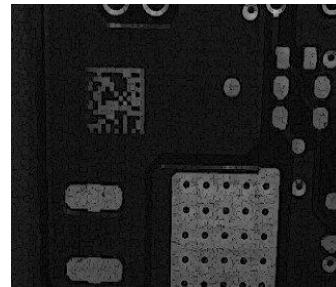
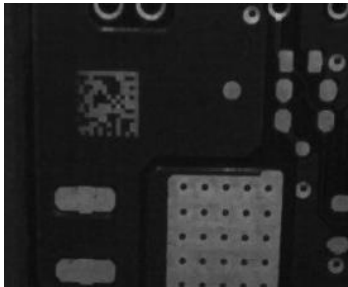
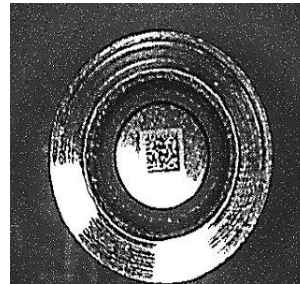
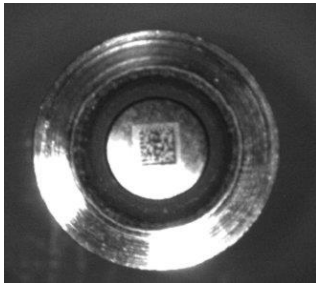

Before - No Read

After - Readable

### Deblurring

The **Black Enhancement** filter produces a nonlinear increase in the black level for light images.

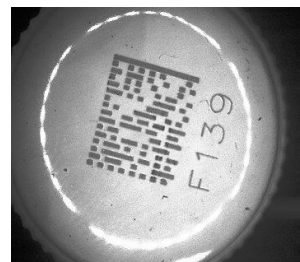
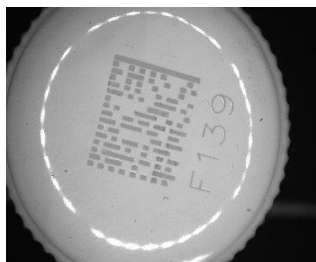

Before - No Read

After - Readable

### Black Enhancement

The **White Enhancement** filter produces a nonlinear increase in the white level for dark images.

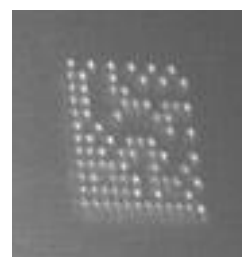

Before - No Read

After - Readable

### White Enhancement

## 7.3 PASS-THROUGH CONFIGURATIONS

Starting from software version 1.3.0, DL.CODE and Matrix N family readers support pass-through multi device configurations.

The pass-through configuration allows individually working devices (Alone), to collect data from other devices (also working Alone), and pass this data to a third device through a different communication channel. See the figure below as an example.

The following screenshots show the pass-through configuration settings for the three devices in the example in par. 5.4.

Layout Type : Alone Internal Network Role : Slave 0 ; Configuration : Station 1; Status : Halt ; Reading Phase: Phase 3

Reader #1

Reading Phase Good Read Setup Data Formatting Output Setup

Output Data Format

- Output Messages
  - Message 1
  - Message 2
- Diagnostic Messages
- Channels
  - Matrix TCP Server 1
  - Matrix TCP Server 2
  - Main
  - Aux
- Fieldbuses
- Images Saving Conditions
- Passthrough Configuration
  - Passthrough

Passthrough Field

Output Data Channels

- Good Read
- Message 1
- No Read
- Message 2
- Matrix TCP Server 2

Matrix TCP Server 1

Matrix TCP Server 2

Main

Aux

Data Formatting : Passthrough

Header <STX>

Terminator <CR><LF>

Passthrough Input Data

Header <STX>

Terminator <CR><LF>

Input Channel Matrix TCP Server 2

Passthrough Content Field

Output Channels

- Matrix TCP Server 1
- Matrix TCP Server 2
- Main
- Aux

Layout Type : Alone Internal Network Role : Slave 0 ; Configuration : Station 2; Status : Halt ; Reading Phase: Phase 3

Reader #2

Reading Phase Good Read Setup Data Formatting Output Setup

Output Data Format

- Output Messages
  - Message 1
  - Message 2
- Diagnostic Messages
- Channels
  - Matrix TCP Server 1
  - Matrix TCP Server 2
  - Main
  - Aux
- Fieldbuses
- Images Saving Conditions
- Passthrough Configuration
  - Passthrough 1
  - Passthrough 2

Passthrough 2 Field

Output Data Channels

- Good Read
- Message 1
- No Read
- Message 2
- Main
- Aux

Matrix TCP Server 1

Matrix TCP Server 2

Main

Aux

Data Formatting : Passthrough 2

Header <STX>

Terminator <CR><LF>

Passthrough Input Data

Header <STX>

Terminator <CR><LF>

Input Channel Aux

Passthrough Content Field

Output Channels

- Matrix TCP Server 1
- Matrix TCP Server 2
- Main
- Aux

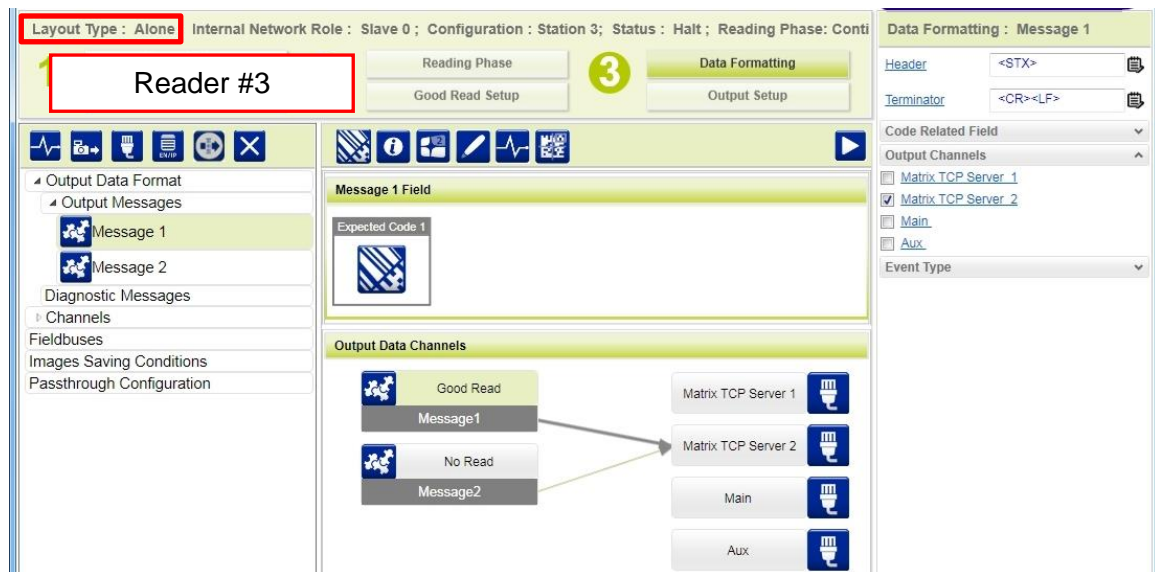

## 7.4 INTERNAL NETWORK CONFIGURATIONS

Internal Network configurations (also called Master/Slave configurations), are designed to collect data from several devices connected together in an ID-NET™ network and send data output to the Host system.

DL.CODE has a Net Autoselect feature for the Internal ID-NET Network which automatically recognizes and assigns addresses to all connected Slave readers.

In order to automatically recognize the ID-NET Slaves, all devices must be physically installed and electrically connected (including ID-NET network wiring).

The general procedure (also detailed in the following paragraphs) is to:

1. Mount all the readers mechanically (refer to par. 3.2 and 3.3) and electrically (refer to par. 4.3) with factory default settings (Layout Type = Alone, Internal Network Role = Slave).

In order to automatically recognize the ID-NET Slaves, all devices must be physically installed and electrically connected (including ID-NET network wiring). Run DL.CODE and verify that all the devices are discovered and shown in the device list area.

2. Connect to the designated Master device in DL.CODE and open the **Setup Internal Network Configuration**. You will be prompted to change the device to Master. Click OK. The Slave units will automatically be recognized. See par. 7.4.1.
3. Depending on the application, select Multidata, Synchronized Phase Mode or Synchronized PackTrack Configuration.
4. Connect to each Slave reader via Ethernet and set the Slave specific parameters depending on the application type. Save each Slave specific configuration. See par. 7.4.2 or 7.4.3.
5. For Synchronized networks Verify/Test network performance. See par. 7.4.4.
6. Perform the **Backup current Internal Network configurations** procedure. See par. 7.5.1.

## 7.4.1 Master Configuration



**NOTE:** The following paragraphs demonstrate example network configurations using a Matrix 300N device. For Matrix 210N readers, Packtrack operating mode is not available.

First start with the desired device to assign as ID-NET Master (current default setting is Slave). Click on Setup Internal Network Configuration from the Task area.

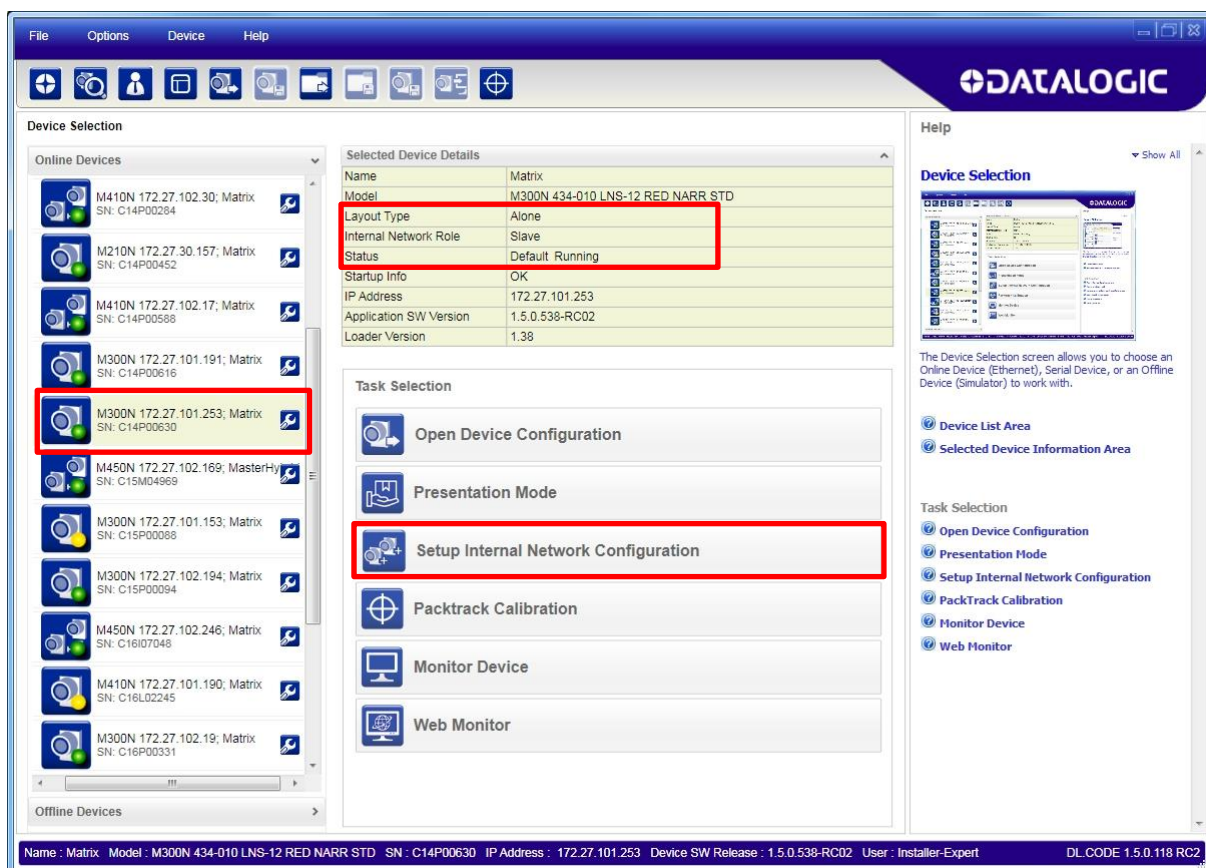

You will be advised that the device role will be changed to Master.

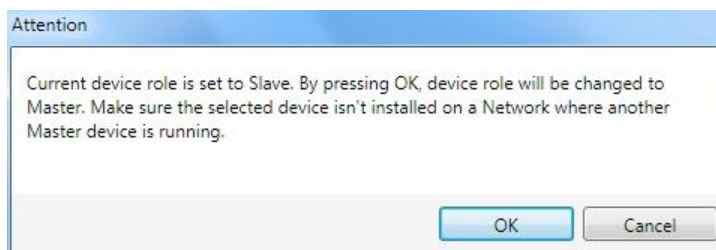

Click OK. The Net Autoset feature automatically starts to find Slave devices connected to the ID-NET network of the Master.



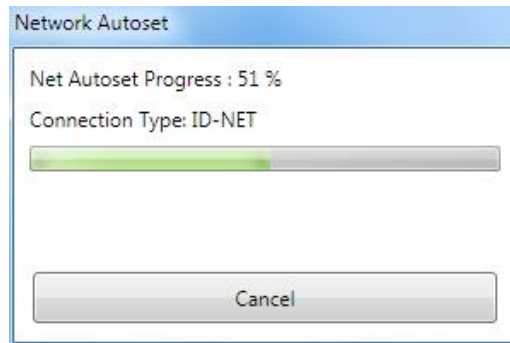

When finished, all the Slaves should have been correctly recognized. If not, verify all device connections and power and then repeat the operation by clicking on the Start Net Autoset button.

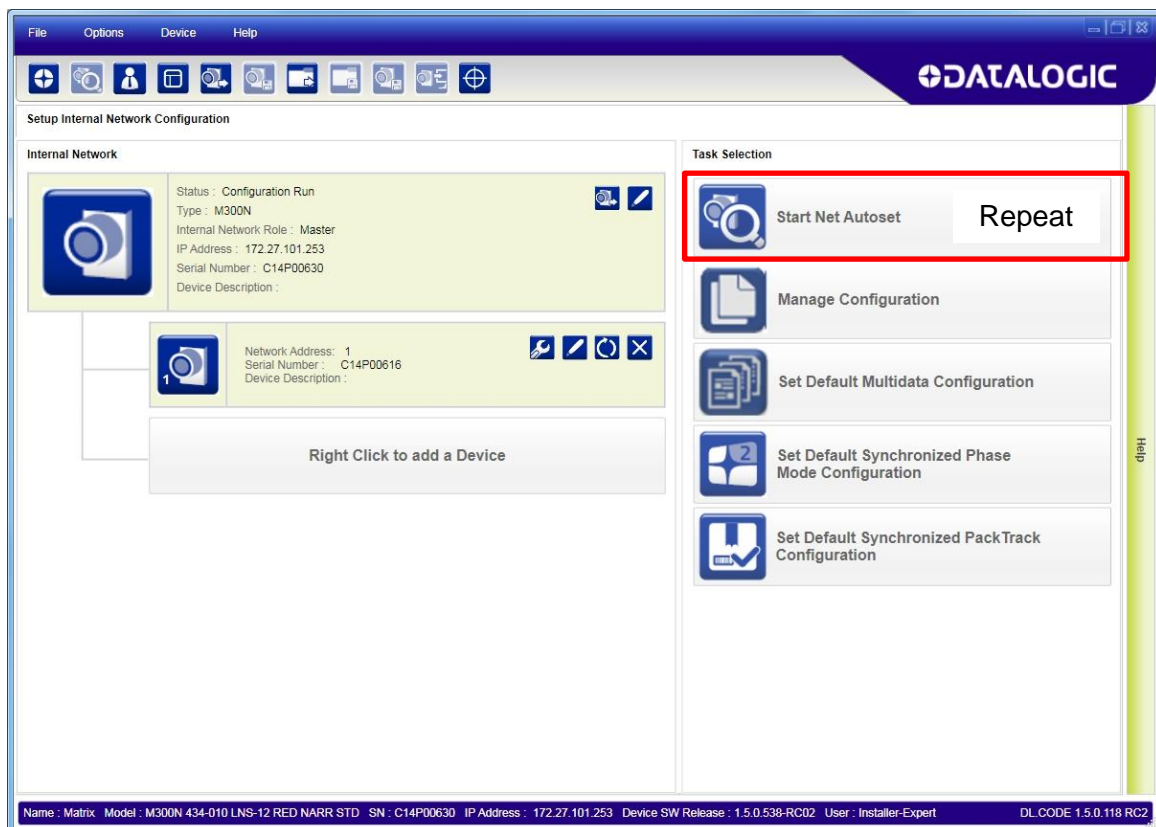

Depending on the application, select one of the Default Internal Network Configurations: **Multidata**, or **Synchronized Phase Mode**.

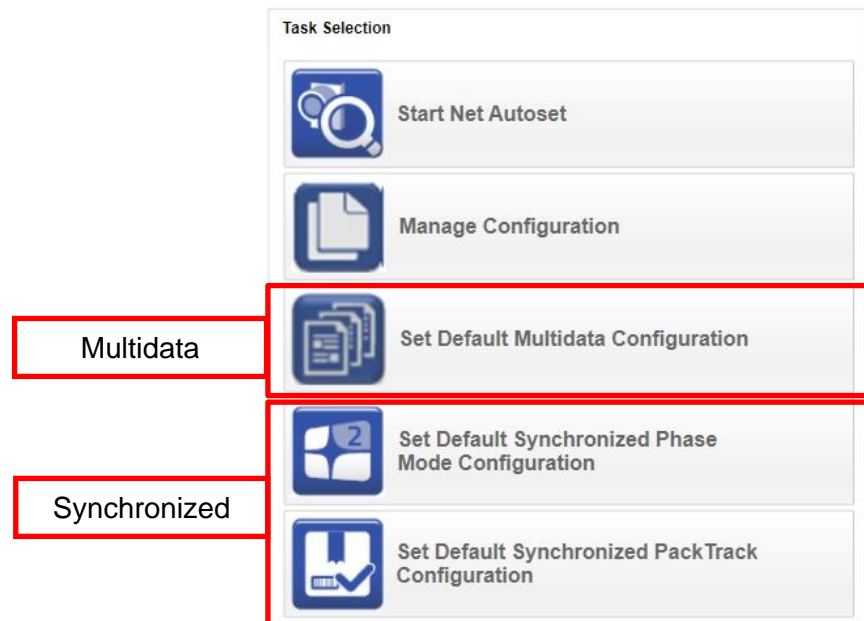

This selection will open a pre-configured job for the Master reader according to the selection. Follow the specific application instructions in the following paragraphs.

## 7.4.2 Multidata ID-NET Network Configurations

The Multidata ID-NET network communications between Master and Slave are managed by the application job (configuration) using the pass-through feature. A pre-configured job is loaded with the correct pass-through settings for both the Master and Slaves when the Default Multidata Configuration is selected from the Internal Network Setting feature.

1. Complete the configuration of all the application parameters (including Image Settings) and save them to the Master with an application specific name. Optionally, checking the **Save on Slave Device** box can be helpful to save all the current individual Slave configurations with the new configuration *name*. This does not clone any parameters. If not checked, Slave configurations will remain as *Temp* configurations and you will be warned that changes to the Master have not been saved to the Cluster. For Multidata configurations, the option to **Clone Master configuration on Slaves** **must not be checked**.

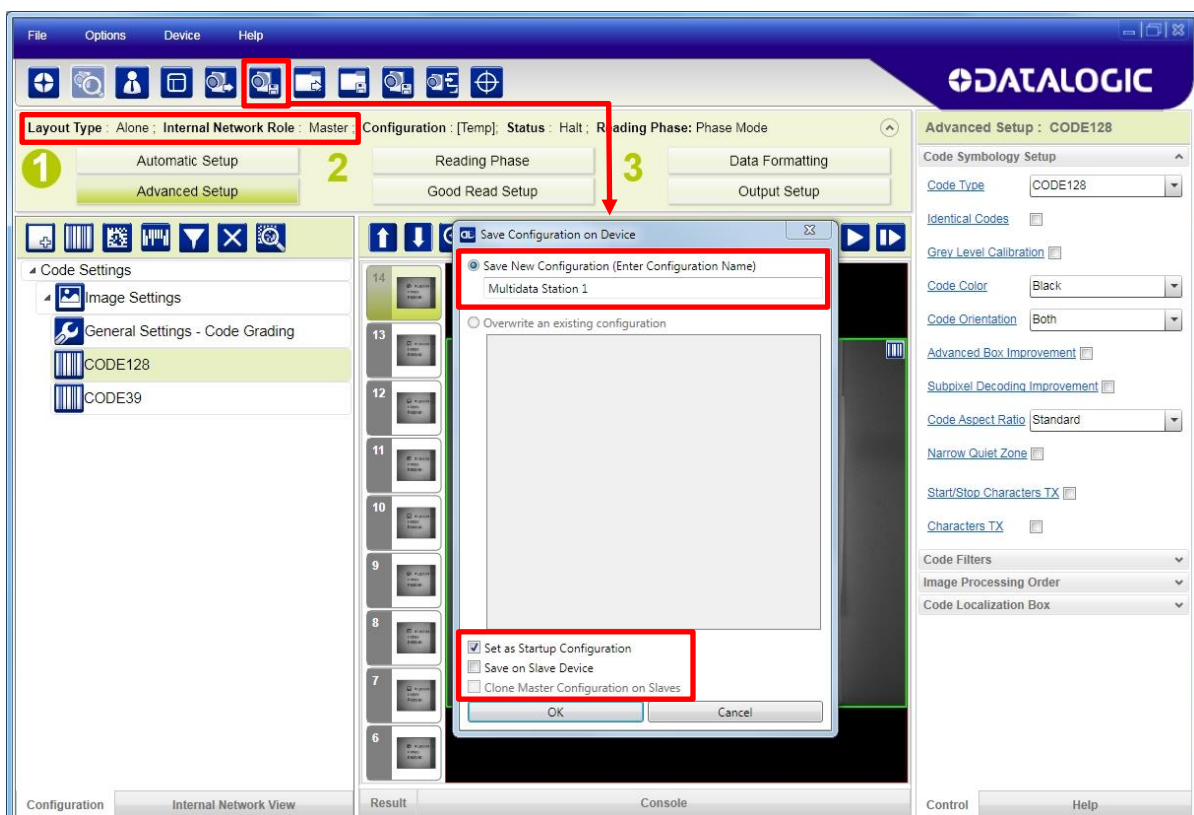

Figure 83 – Saving Multidata Configuration to Master

The jobs must not be cloned because the Master and Slaves have different input/output communication channels. The readers are also working independently from each other, often on separate stations with different code reading requirements, different operating modes, etc.

2. Connect to each Slave reader via Ethernet (see note below), and set all the configuration parameters of each Slave device.



**NOTE:** If necessary, Slave device photometric (Image Settings) parameters must be configured separately through DL.CODE. This is preferably done through each device's Ethernet TCP/IP channel. If Slave devices are not connected to Ethernet you must temporarily (manually) connect them one by one to perform Image Settings.

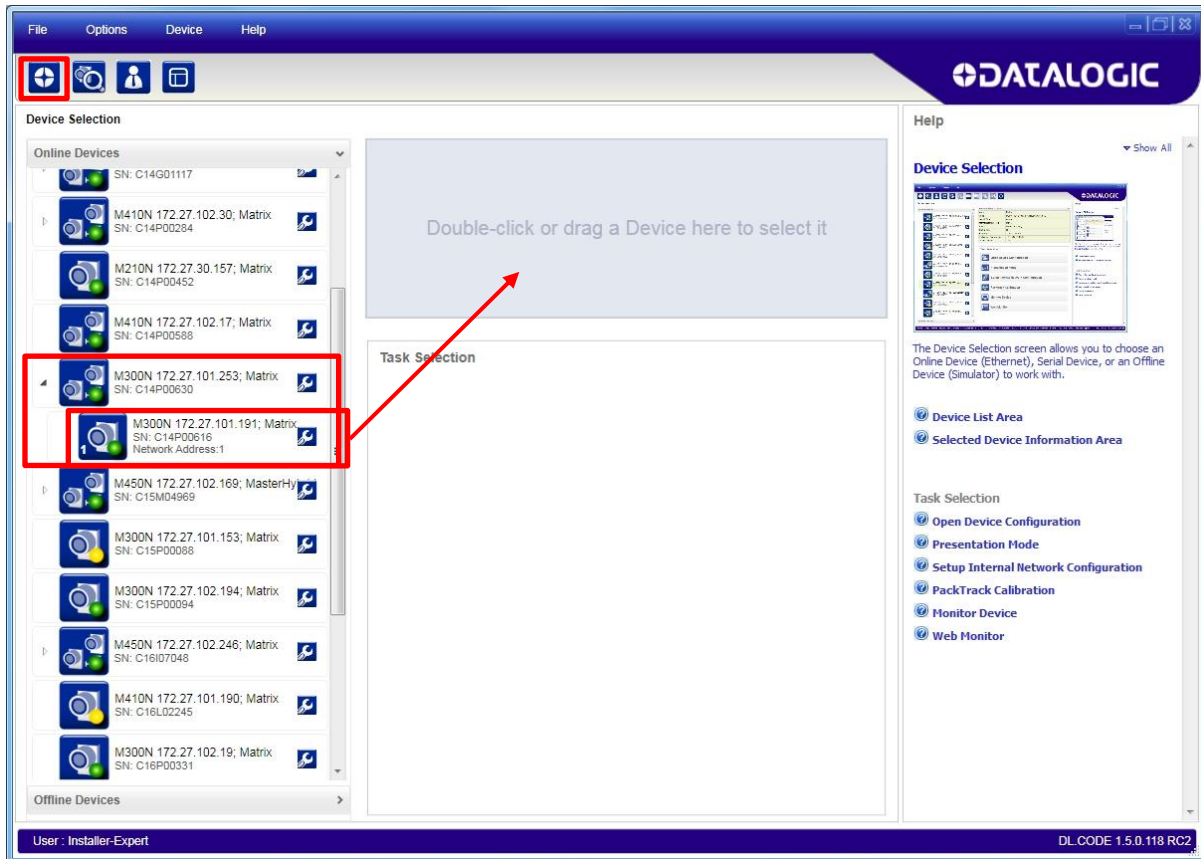

Open the **Slave specific application** job, (it will either have the new name saved from the Master or Temp depending on the **Save on Slave Device** selection).

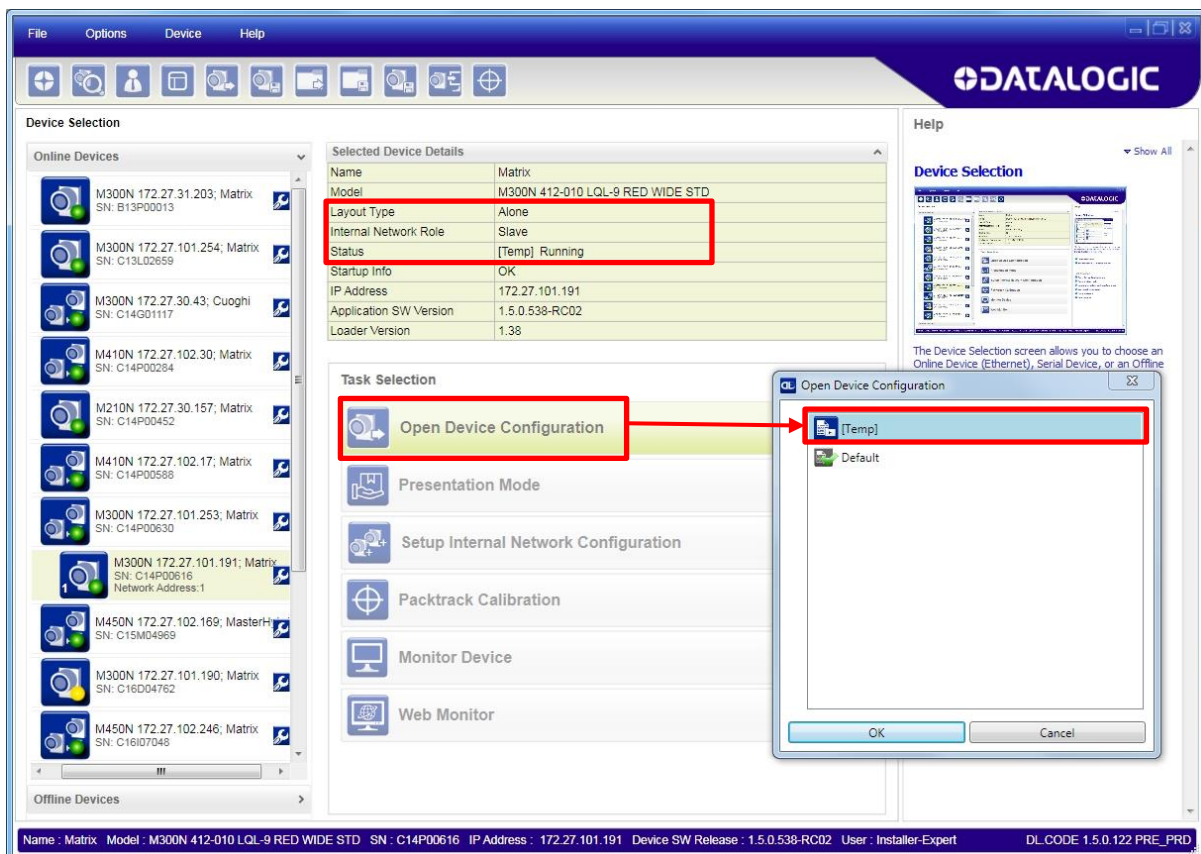

When the configuration opens, pause run mode and set all the application specific configuration parameters (including Image Settings).

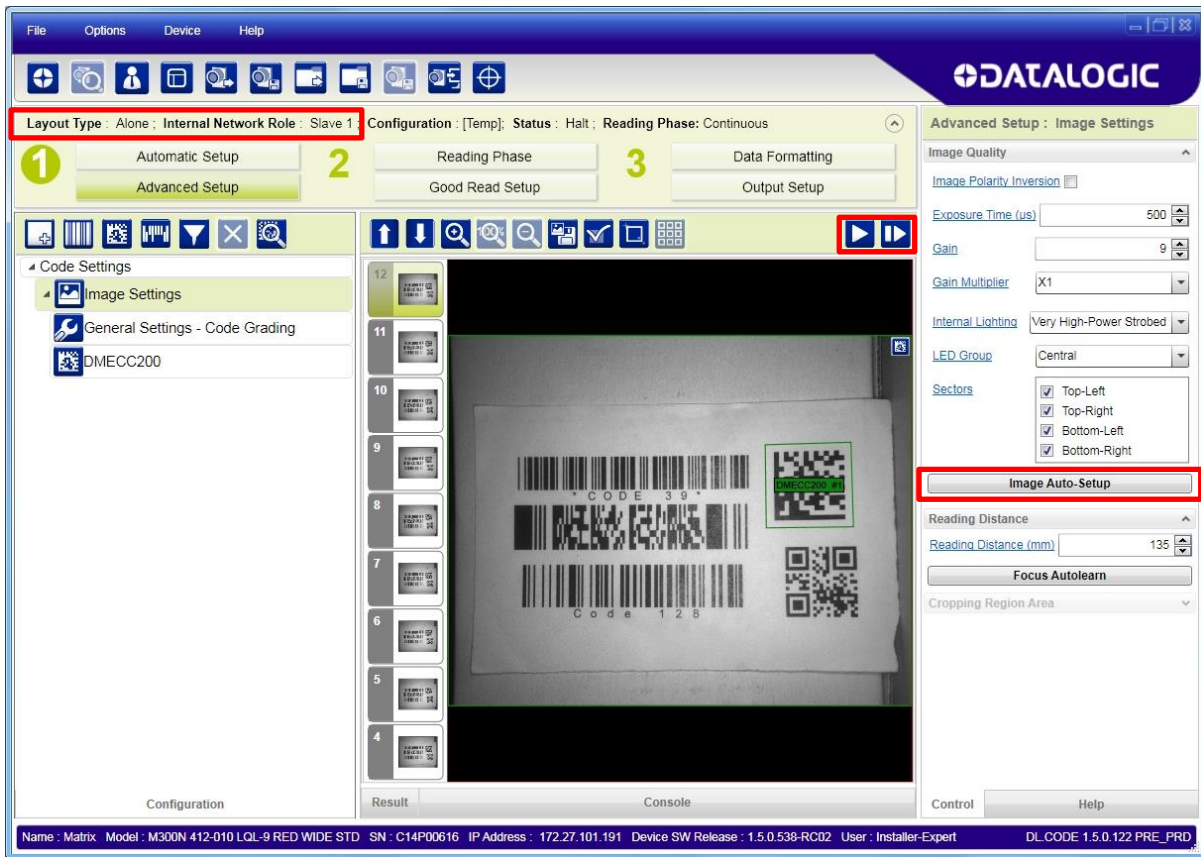

Verify the focus and decoding with the capture image .

2. Now save them to a new Slave specific application job<sup>5</sup>.

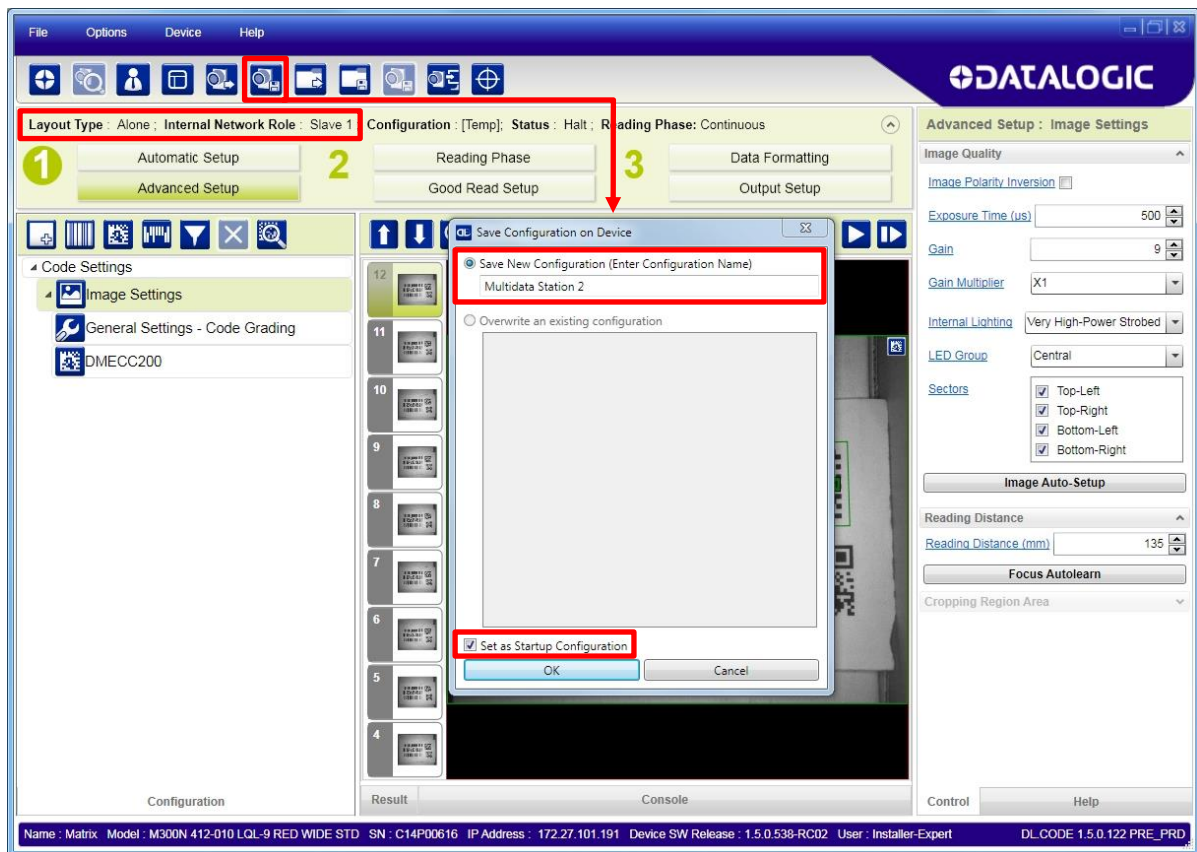

Figure 84 – Saving Multidata Configuration to Slave 1

Repeat this procedure for each Slave device until the entire network is configured.

The following screenshots show the pass-through configuration settings for the three devices in the example in par. 5.5.

<sup>5</sup> If **Save on Slave Device** was selected when saving the Master configuration, an application job with the same name (but with all Slave specific configuration parameters), has been saved to the Slaves. No parameters have been cloned from the Master. There are no common parameters managed by the Master for Multidata configurations.

Layout Type : Alone ; Internal Network Role : Master Configuration : [Temp]; Status : Halt ; Reading Phase: Phase M

**ID-NET Master**

Reading Phase 3 Data Formatting  
Good Read Setup Output Setup

Data Formatting : Passthrough 2  
Header <STX>  
Terminator <CR><LF>  
Passthrough Input Data  
Header <STX>  
Terminator <CR><LF>  
Input Channel: ID-Net  
Passthrough Content Field  
Output Channels  
 Matrix TCP Server  
 Main  
 Aux

Output Data Format  
Output Messages  
Message 1  
Message 2  
Diagnostic Messages  
Channels  
Matrix TCP Server  
Main  
Aux  
ID-Net  
Fieldbuses  
Images Saving Conditions  
Passthrough Configuration  
Passthrough 1  
Passthrough 2

Passthrough 2 Field

Output Data Channels  
Good Read  
Message1  
No Read  
Message2  
Main  
Passthrough1  
ID-Net  
Passthrough2

Matrix TCP Server  
Main  
Aux

Layout Type : Alone ; Internal Network Role : Slave 1 Configuration : [Temp]; Status : Halt ; Reading Phase: Phase I

**ID-NET Slave #1**

Reading Phase 3 Data Formatting  
Good Read Setup Output Setup

Data Formatting : Passthrough  
Header <STX>  
Terminator <CR><LF>  
Passthrough Input Data  
Header <STX>  
Terminator <CR><LF>  
Input Channel: Aux  
Passthrough Content Field  
Output Channels  
 Matrix TCP Server  
 Main  
 Aux  
 ID-Net

Output Data Format  
Output Messages  
Message 1  
Message 2  
Diagnostic Messages  
Channels  
Matrix TCP Server  
Main  
Aux  
ID-Net  
Fieldbuses  
Images Saving Conditions  
Passthrough Configuration  
Passthrough

Passthrough Field

Output Data Channels  
Good Read  
Message1  
No Read  
Message2  
Aux  
Passthrough

Matrix TCP Server  
Main  
Aux  
ID-Net

Layout Type : Alone ; Internal Network Role : Slave 2 Configuration : [Temp]; Status : Halt ; Reading Phase: Contin

**ID-NET Slave #2**

Reading Phase 3 Data Formatting  
Good Read Setup Output Setup

Data Formatting : Message 1  
Header <STX>  
Terminator <CR><LF>  
Code Related Field  
Output Channels  
 Matrix TCP Server  
 Main  
 Aux  
 ID-Net  
Event Type

Output Data Format  
Output Messages  
Message 1  
Message 2  
Diagnostic Messages  
Channels  
Fieldbuses  
Images Saving Conditions  
Passthrough Configuration

Message 1 Field  
Expected Code 1

Output Data Channels  
Good Read  
Message1  
No Read  
Message2

Matrix TCP Server  
Main  
Aux  
ID-Net

### 7.4.3 Synchronized ID-NET Network Configurations

The Synchronized ID-NET network communications between Master and Slave are internally managed by the application software. A pre-configured job is loaded with the Synchronized Layout Type and the correct Operating Mode for both the Master and Slaves when either the Phase Mode or PackTrack Configuration is selected from the Internal Network Setting feature.

1. Complete the configuration of all the application parameters (including Image Setup) and save them to the Master with an application relative name and **with the option to Clone Master configuration on Slaves**.

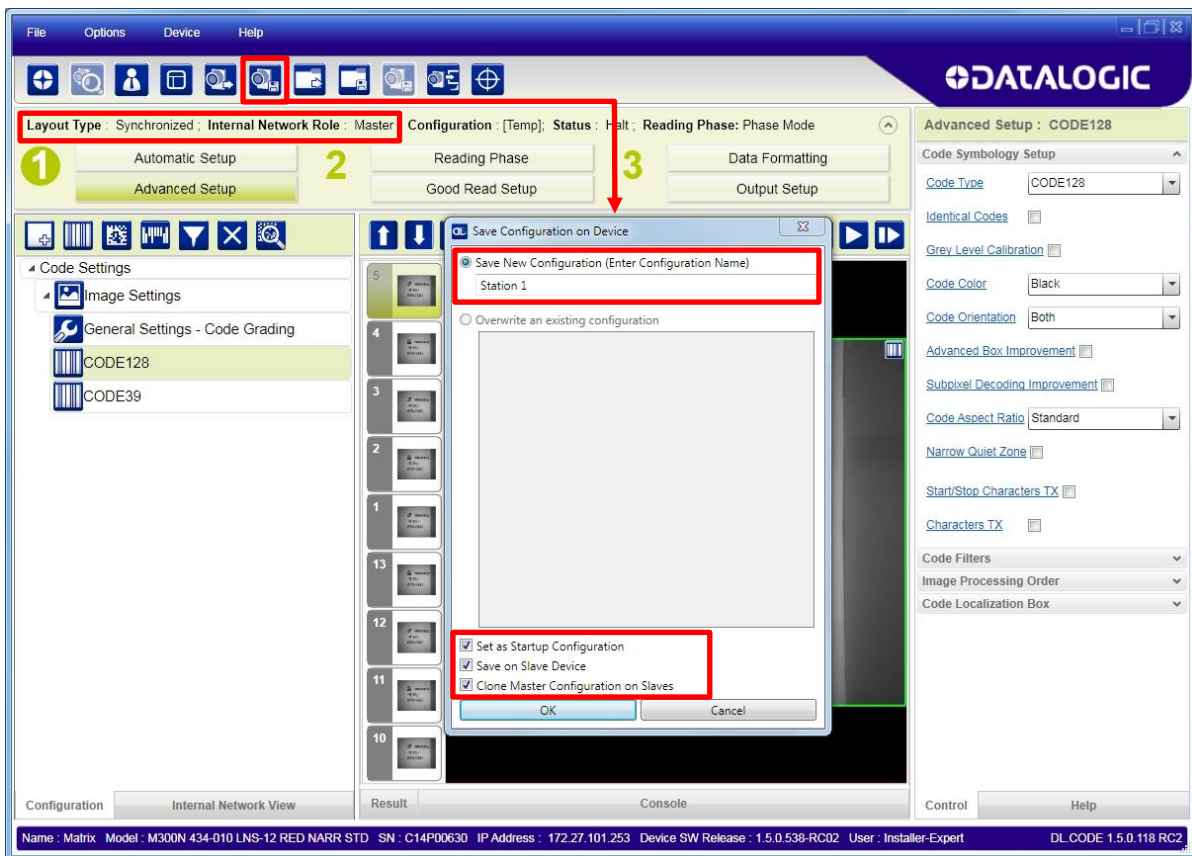

Figure 85 – Saving Synchronized Phase Mode Configuration to Master

2. Connect to each Slave reader via Ethernet (see note below), and set the Slave specific parameters.



**NOTE:** If necessary, Slave device photometric (Image Settings) parameters must be configured separately through DL.CODE. This is preferably done through each device's Ethernet TCP/IP channel. If Slave devices are not connected to Ethernet you must temporarily (manually) connect them one by one to perform Image Settings.



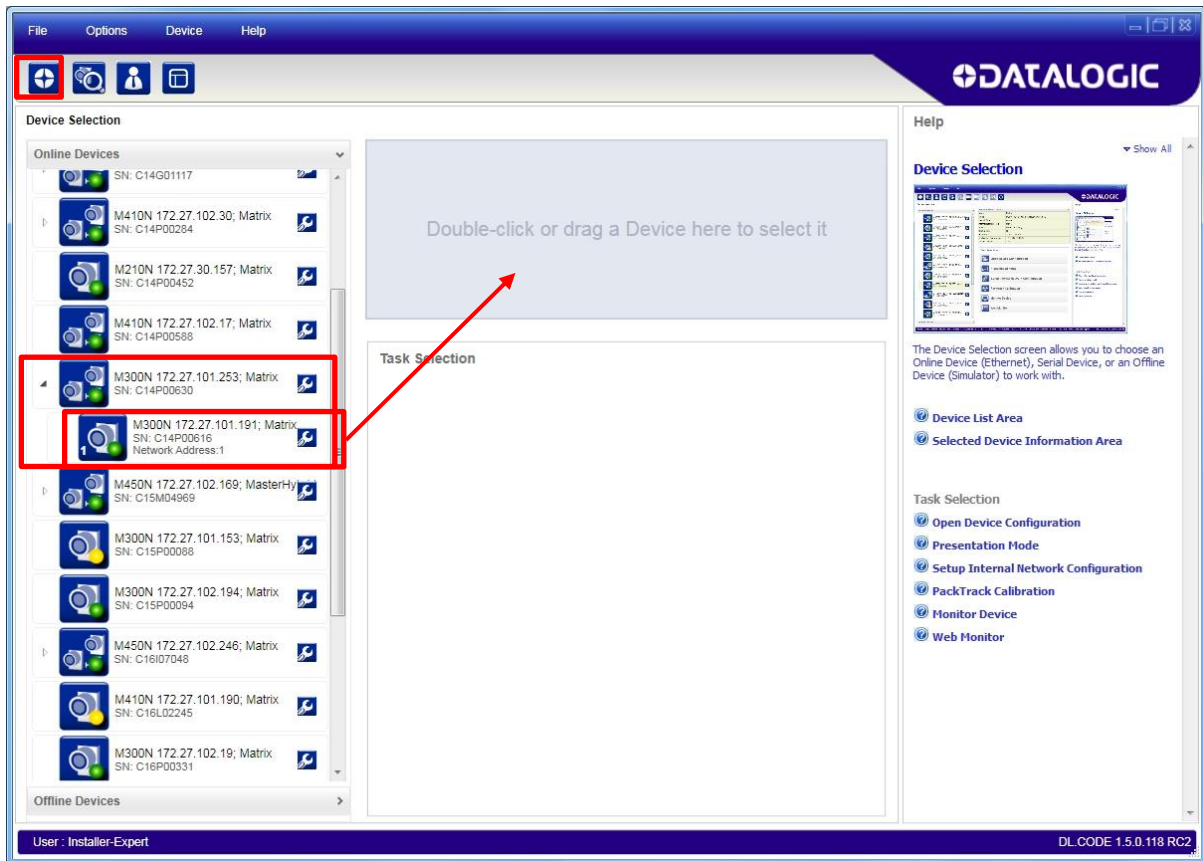

Open the cloned application job.

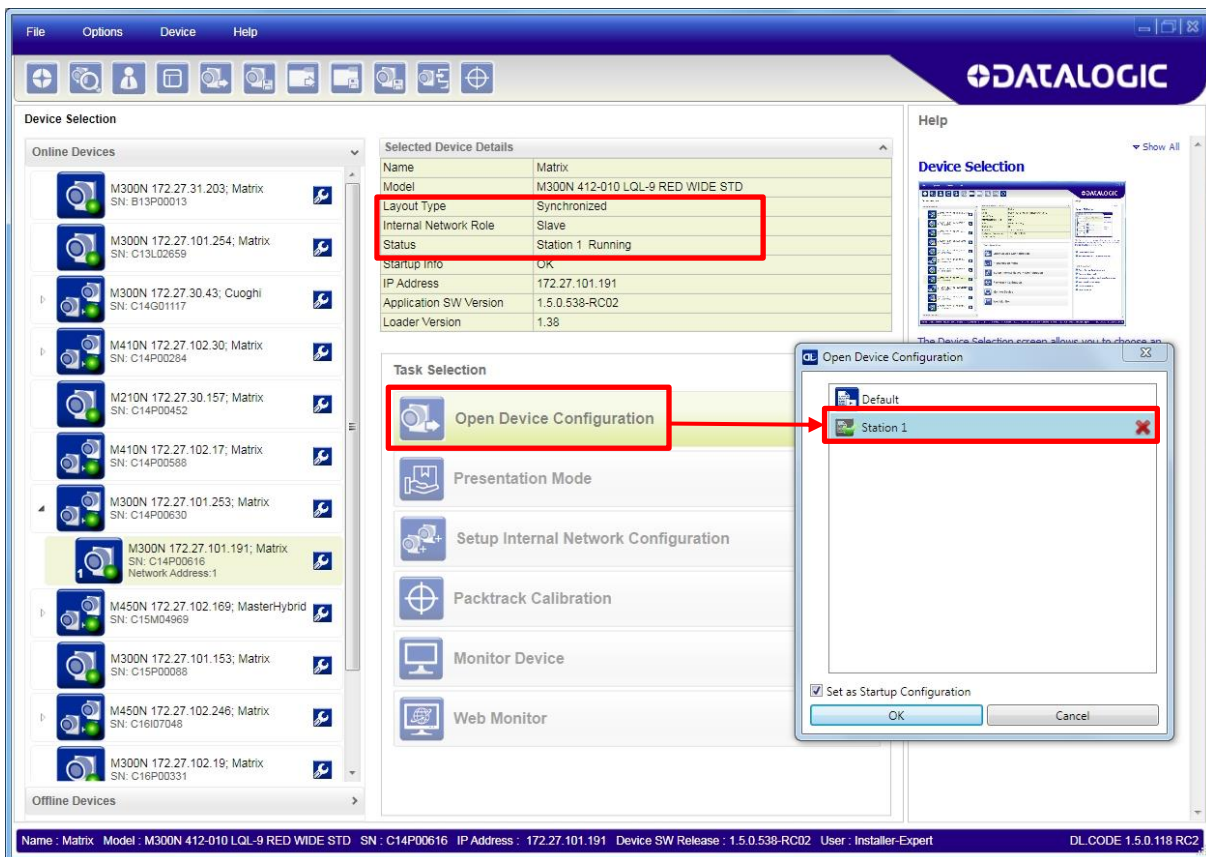

When the job opens, pause run mode and configure the Slave specific parameters. These depend on the application and include the following:

- photometric parameters (Image Auto-Setup feature in the Advanced Setup – Image Settings step)
- Acquisition Trigger Delays necessary to avoid lighting interference between adjacent or oppositely positioned readers (Reading Phase step)
- Images Saving if used (Data Formatting step)
- Encoder Sensor: if used, (for all Slaves, the Encoder Type must be set to **Internal**)

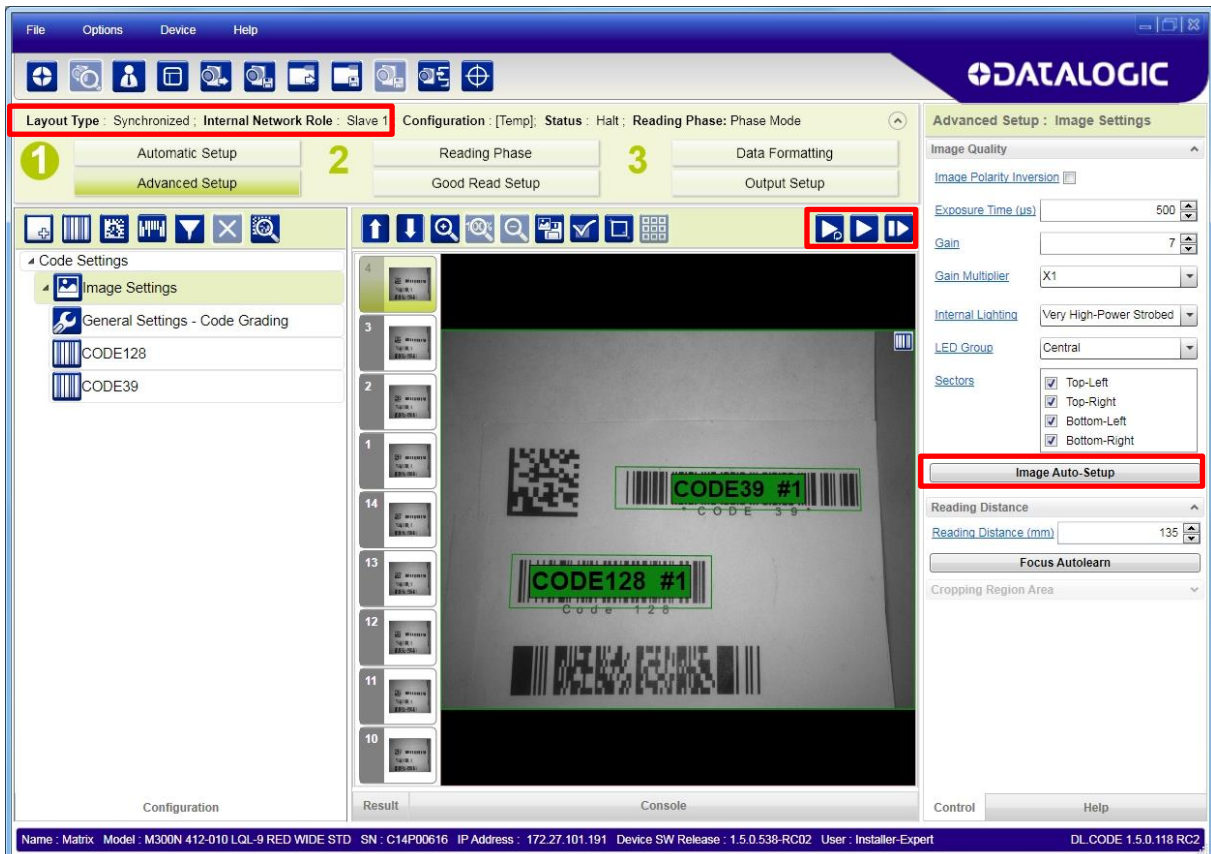

Verify the focus and decoding with the capture image .

3. Now save them, overwriting the cloned application job<sup>6</sup>.

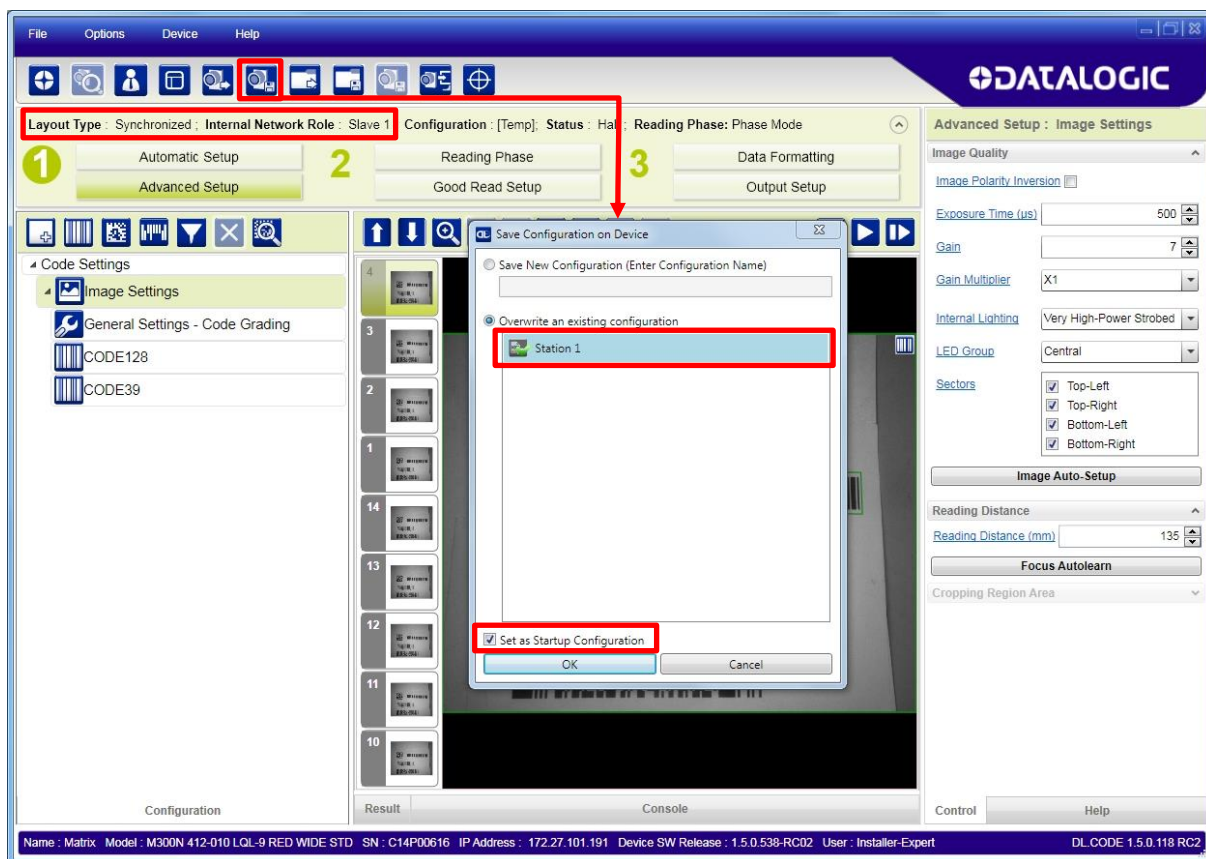

**Figure 86 – Saving Synchronized Phase Mode Configuration to Slave**

Repeat this procedure for each Slave device until the entire network is configured.

See par. 5.6 for an example Synchronized ID-NET configuration.

<sup>6</sup> An application job with the same name as the Master's has been cloned to the Slaves. Each Slave can have its own Image Settings parameters saved in its own copy of the application job. Common parameters managed by the Master such as Operating Mode cannot be modified in the Slave jobs and are shown in dark grey.

### 7.4.4 Verify Master/Slave Synchronized Configuration

From the Master configuration, run the application and monitor the output data from the DL.CODE Console or a configured channel terminal.

If necessary, as a troubleshooting tip, you can temporarily apply the **Reading Mask** field in place of each Code Content field to verify if all devices are reading. To do this:

1. Connect to the Master device via Ethernet and from the Data Formatting step, change each Expected Code Field Type from Code Content to Reading Mask.

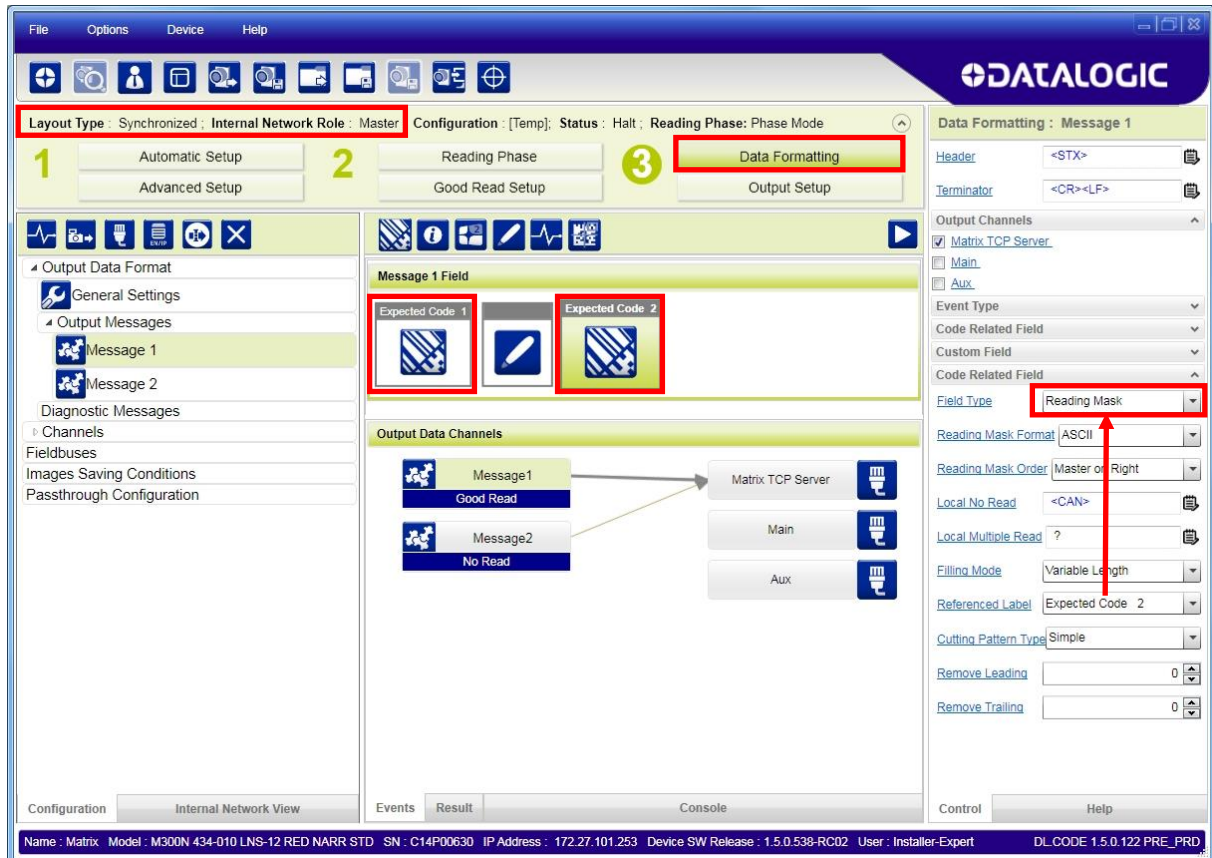



To view the connected Slave configurations:

1. Click on the Internal Network View tab at the bottom of the screen.
2. Open the Master branch by clicking on the arrow to the left of the Master icon.
3. Select any slave. Wait for the configuration to load.
4. Click The Configuration tab at the bottom of the screen.

By selecting the various configuration steps above you can visualize the slave configuration.

The screenshot shows the Datalogic software interface. At the top, there are menu options: File, Options, Device, Help. Below the menu is a toolbar with various icons. The main area is divided into several sections:

- Top Bar:** Layout Type: Synchronized, Internal Network Role: Slave 1, Configuration: Station 1, Status: Halt, Reading Phase: Phase Mode.
- Navigation Buttons:** 1. Automatic Setup, 2. Reading Phase, 3. Data Formatting, Advanced Setup, Good Read Setup, Output Setup.
- Internal Network View:** Shows a list of devices. The first device is highlighted with a red box and an arrow pointing to its left arrow icon. The device details are: M300N 434-010 172.27.101.253 Matrix Master, Network Address: 1, SN: C14P00616, Device Description: .
- Image Setup Table:**

Image Name	Phase Id	Size	PPI	Image Processing Time (ms)	Field Of View	Exposure (µs)	Gain
Image Setup	95	1280x1024	201	27	161x129	500	7
- Code Settings Table:**

Name	Symbology	Data	Number of Characters	Position (pix)	Angle (deg)
CODE39 #1	CODE39	CODE 39	7	811x302	1
- Advanced Setup:** CODE39, Code Symbology Setup, Code Type: CODE39, Identical Codes, Grey Level Calibration, Code Color: Black, Code Orientation: Both, Advanced Box Improvement, Subpixel Decoding Improvement, Code Aspect Ratio: Standard, Narrow Quiet Zone, Character Set: Standard, Code 32 Decoding, Check Digit Status, Code Filters, Image Processing Order, Code Localization Box.
- Bottom Bar:** Configuration, Internal Network View, Control, Help.
- Status Bar:** Name: Matrix, Model: M300N 434-010 LNS-12 RED NARR ST, SN: C14P00630, IP Address: 172.27.101.253, Device SW Release: 1.5.0.538-RC02, User: Installer-Expert, DL\_CODE 1.5.0.122 PRE\_PRD.



**NOTE:** You can modify some Slave Synchronized parameters from this view but you cannot save them here.

To save changed slave parameters here, you must click on the Master and Save the configuration overwriting it, making sure to select **Save on Slave Device** but **without Clone Master Configuration on Slaves**, otherwise all the Slave configuration parameters will be overwritten by the Master configuration.

## 7.5 BACKUP AND RESTORE THROUGH DL.CODE

DL.CODE allows Backup and Restore to be performed to/from the configuration PC via file or to an external storage device such as BM100/BM150.

DL.CODE provides complete backup and restore functions (Configuration and Environmental parameters) with the following difference:

For Single Readers or individual ID-NET Slaves:

- Backup and Restore functions provide parameter storage including all configuration jobs present on the reader.

For Master Readers in ID-NET Master/Slave networks:

- Backup and Restore functions provide parameter storage of only the Startup Configuration for the Master and all Slaves present in the network.



**CAUTION:** For Master/Slave networks any other configurations (jobs) stored in the device memory will not be backed up. Therefore upon a restore, all jobs other than the startup configuration will be overwritten (erased). It is strongly recommended to save all configurations to backup files.

**The Slaves must always be configured with the same network baudrate as the Master for correct functioning including performing Backup and Restore procedures.**

When performing Backup and Restore to/from file, device firmware can be included.

Regardless of the reader's network configuration, Backup to and Restore from external device is supported by DL.CODE for any reading device when connected to:

- CBX + BM100
- QLM-Series Gateways



**NOTE:** Before executing a Backup to a BM100 backup module make sure the Write Protection switch is set to Unlocked.

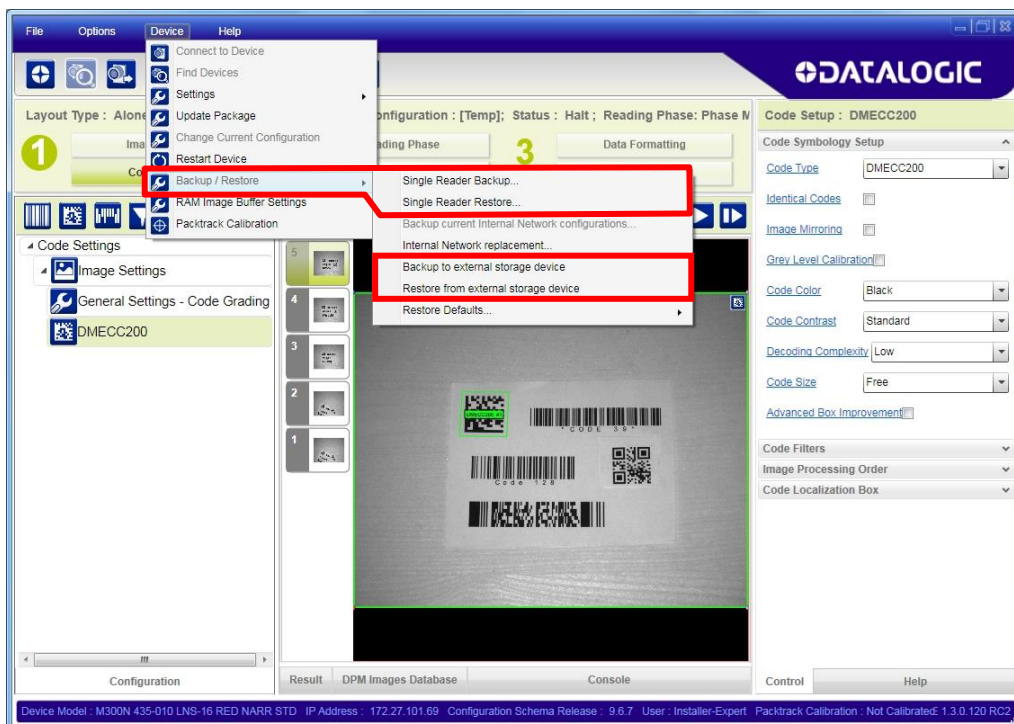

## 7.5.1 Backup

To perform a **Backup**:

1. From the DL.CODE Device menu, select either **Single Reader Backup** (to file on PC); or **Backup to external storage device**.



**NOTE:** For ID-NET network Backup (Master only), select the **Backup current Internal Network configurations** selection.

You will be reminded that configuration in temporary memory will not be saved so you should save the configuration to the reader before performing Backup.

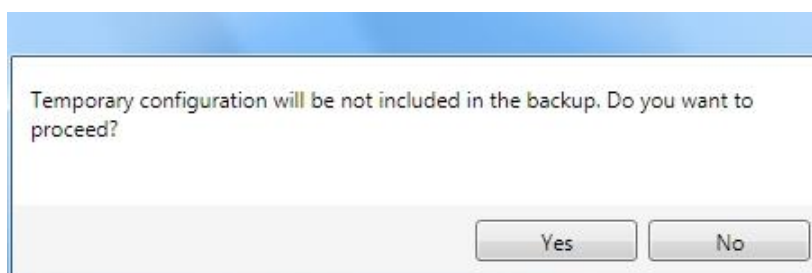

If you are performing a backup to a file you will be asked whether to include the firmware or not.

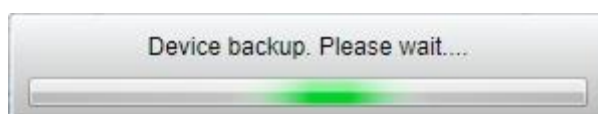
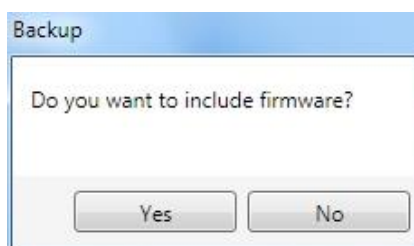

At the end of the backup, DL.CODE shows a message indicating successful completion.

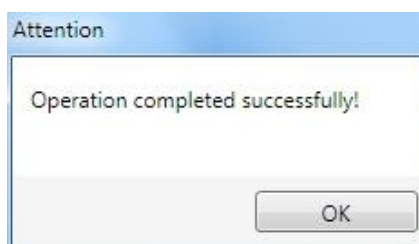



## 7.5.2 Restore

To perform a **Restore**:

1. From the DL.CODE Device menu, select either **Single Reader Restore** (from file on PC); or **Restore from external storage device**.



**NOTE:** For ID-NET network Restore (Master only), select the **Internal Network replacement** selection.

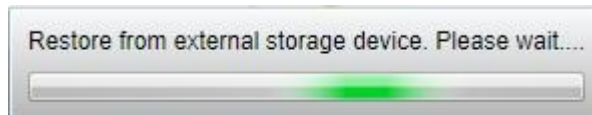

If restoring an ID-NET network through the Master, this may take a few minutes.

At the end of the restore, DL.CODE shows a message indicating successful completion.



## 7.5.3 Replacement



**CAUTION:** The replacement device **must be the exact same model** as the device it is replacing.

The **Restore** function also provides easy and secure Single Device Replacement:

1. Remove the device to be replaced.
2. Connect the new device (make sure the new device has been previously set to factory default).
3. Run the Restore procedure by selecting either **Single Reader Restore** (from file on PC) or **Restore from external storage device** item (see: Restore procedure).



**NOTE:** In case of Backup or Restore operation failures, error messages will be displayed in the Monitor Diagnostic page.

## 7.6 RESTORE DEFAULTS

The device parameters are divided into two main classes, Configuration and Environment which are affected differently by the Restore Defaults commands.

- The Configuration parameters are the ones set in the various steps of the configuration process and are specific to each application. When multiple configurations (jobs) are saved on a single device, these parameters can be different from one configuration to the next.
- Environment parameters regard the device Identity and Position in a Network (Ethernet, ID-NET, etc.) and are not influenced by the Default (or any other) Configuration present in memory.

### 7.6.1 Restore Default Startup Configuration

The Default configuration is always present on the reader and in fact it is not modifiable and cannot be deleted. It can always be restored by simply selecting it from the Open from Device configuration list.

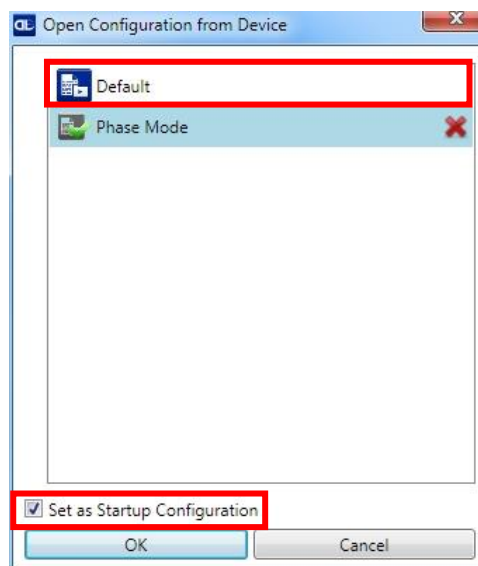

The same action can be performed from the Device menu >Backup/Restore > Restore Defaults > **Restore Default Startup Configuration**. The Default Configuration will be set to run at startup and the reader will be reset.

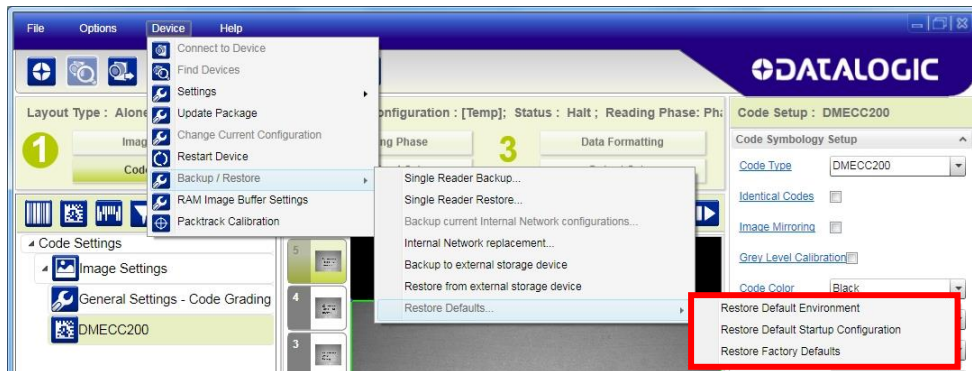

Any previously saved configurations on the device will remain in memory, but the Default configuration is set as the startup configuration.

## 7.6.2 Restore Default Environment

**Restore Default Environment** returns all Environment parameters to their factory default settings. The default IP address will be restored as well as all the parameters managed in the Device Environment Configuration window.

The Factory Default static IP address for all Matrix N Family readers is:

**IP Address = 192.168.3.100**

Any previously saved configurations on the device will remain in memory, but the Default configuration is set as the startup configuration.

### 7.6.3 Restore Factory Defaults

In order to return a device to its absolute Factory default parameters (for example device replacement) it is necessary to use the **Restore Factory Defaults** command. You will be prompted to confirm.

All Environment parameters will be restored to Factory default values **and any existing configurations stored on the device will be erased**. The device will be reset and therefore start in run mode with the factory default configuration.

## 7.7 DIAGNOSTIC ALARMS

By using the **DL.CODE Monitor** functions from the File menu (or Monitor icon), you can get information about the state of the ID-NET network.

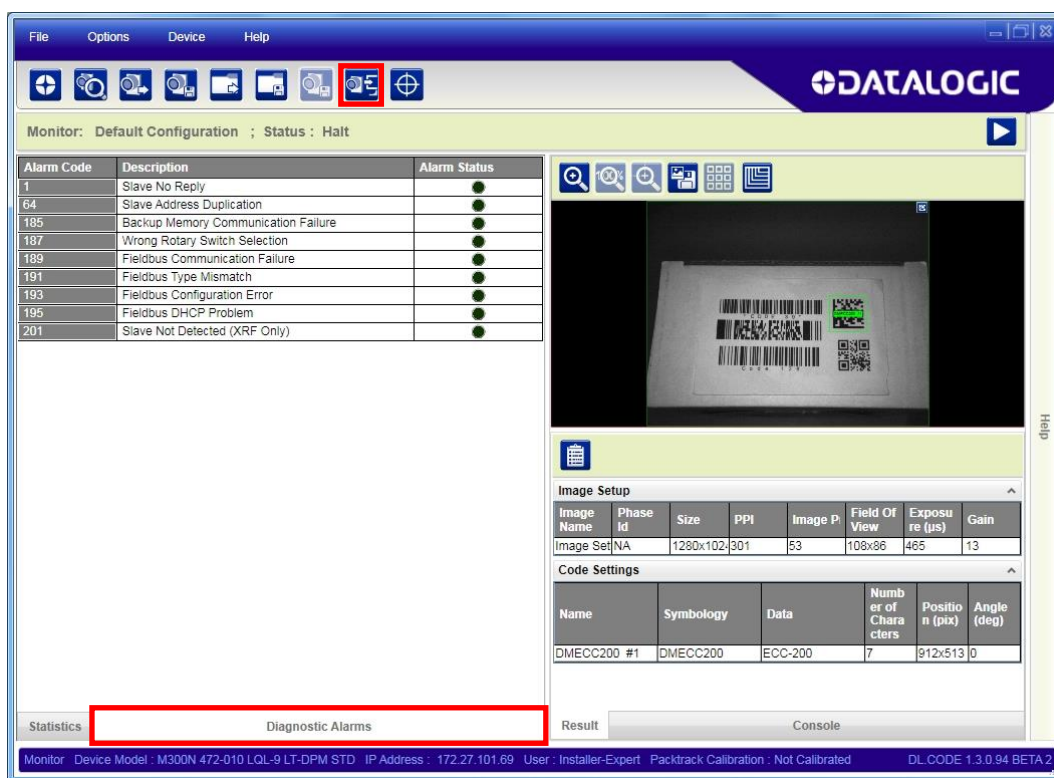

Figure 87 - Diagnostic Alarms

## 7.8 STATISTICS

Statistics on the reading performance can be viewed by enabling the Statistics panel from the **DL.CODE Monitor** item selected from the File menu (or Monitor icon).



Figure 88 - Reading Statistics

The enabled Statistical Counters can be selected from the Device>Settings>Configuration Settings menu.

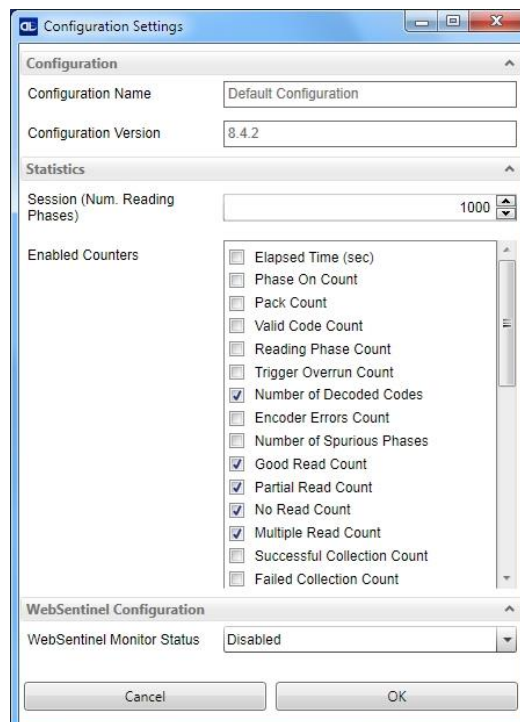

## 7.9 BM150 DISPLAY MODULE CONFIGURATION AND MESSAGES

The BM150 display module is an optional accessory for the CBX500 connection box. Although independent, it is an extension of the reader's HMI Interface, so through its keypad it provides execution of HMI features such as Test, Focus/Locate, Calibration and Code Setting. It also displays device status information, reading results, diagnostic and network messages. Since it connects through the BM100 backup memory module, it provides access to Backup and Restore features through its Extended menu.

### 7.9.1 Configuration Through DL.CODE

BM150 must be detected through the BM100 backup memory module at power-up/reset and this is done through a command setting in DL.CODE. By connecting the reader to DL.CODE the following parameters can be managed.

In the Device>Settings>Settings>Maintenance window:

- **Enable BM100 Detection**

Checked (Enabled): the BM100 backup memory module will be detected on power-up/reset; therefore the BM150 display module (if present), will also be enabled.

Unchecked (Disabled): the BM100 backup memory module will **not** be detected on power-up/reset; therefore the BM150 display module (if present), will also **not** be enabled.

- **BM150 Display Layout (Master Only)**

Reading Mask Only: the Reading Mask screen is sent to the BM150 display.

Reading Mask/Device State: the Reading Mask/Device State screen is sent to the BM150 display.

### 7.9.2 Accessing the HMI Interface Through Keypad and Display Menu

Through its keypad and display, the BM150 provides a remote extension of the reader's HMI Interface. The HMI default menu items can be accessed as well as the View menu for Master devices and the Extended menu for Backup and Restore functions.

To enter the Main Menu press the **Up** and **Down** buttons simultaneously.

The menu structure is shown below.



**Up   Enter   Down**

**Figure 89 – BM150 Keypad**

#### Main Menu:

1. **[Exit]** (exits HMI Interface menu)
2. **Test Mode** (performs Test mode)
3. **Focus/Locate** (performs Focus function: turns on Blue Diamonds and laser pointers)
4. **Calibration** (performs Setup function)
5. **Code Setting** (performs Learn function)
6. **Match Code Tra...**(Training: allows reading a code and storing it as the Match code)

## 7. View Menu (Master Only):

1. **[Exit]** (returns to Main menu)
2. **Standard** (displays the Standard Reading Results screen during run mode)
3. **Reading Mask** (displays the Reading Mask or Reading Mask/Device State screen during run mode) depends on the selection in DL.CODE see par. 7.9.1.
4. **Network State** (displays the Network State screen during run mode)

## 8. Extended Menu:

1. **[Exit]** (returns to Main menu)
2. **Backup** (performs Backup - uninterruptible)
3. **Restore** (performs Restore - uninterruptible)
4. **Erase** (erases the backup configuration in external memory - uninterruptible)

To move through the list press and release the **Up** or **Down** key.

To select an item or enter a submenu, press and release the **Enter** key. After executing an HMI function the display shows a result message and then automatically exits from the menu structure.

To exit a menu manually, press and release the **Enter** key at the [Exit] item or press the **Up** and **Down** buttons simultaneously.

To exit from a running HMI function, press the **Up** and **Down** buttons simultaneously. These functions will also exit upon their configured timeout.



**NOTE:** When the HMI Interface is entered from either the Local Device (reader) or Remote Device (BM150), the key(s) on the other device are disabled.



**NOTE:** When the reader is connected to DL.CODE, access to the BM150 HMI Interface is disabled.



**NOTE:** The "Reset Reader to Factory Default Environment" function of the HMI Interface is only available on the local device (reader), and not on the BM150.

### 7.9.3 Display Messages

The following examples of Remote Display messages are given to help interpret the information reported. The content of these messages depends on the connected reader.

#### Welcome Message:

```
M M M M M M M M M M M M M
K K K V V V V V V V V V R R R N N N
S N D D D D D D D D D
E T H A A A . A A A . A A A . A A A
```

M = scanner model

K = software – STD=Standard, SS =Special

V = software version

R = Device Network Type – MUL=Multidata, SYN=Synchronized, ALN=Alone

N = Device Network Setting – M00=ID-NET Network Master, Sxx= ID-NET Network Slave address, Null string= Alone (no network)

D = device serial number

A = Ethernet IP Address

#### Test Mode Results:

```
A A A % Z Z Z Z Z Z Z Z Z Z Z Z Z Z Z Z Z Z Z
Z Z Z Z Z Z Z Z Z Z Z Z Z Z Z Z Z Z Z Z Z Z
Z Z Z Z Z Z Z Z Z Z Z Z Z Z Z Z Z Z Z Z Z Z
```

A = reading percentage from 000 to 100%.

Z = code content.

#### Calibration (Setup) Results:

```
E x p = X X X X
G a i n = G G
C a l i b r a t i o n
O K ( p e r m a n e n t )
```

X = exposure value (in  $\mu$ s).

G = gain value

#### Code Setting (Learn) Results:

```
X X X X X X X X X
C o d e S e t t i n g
O K ( p e r m a n e n t )
```

X = recognized code symbology.



**Diagnostic Alarms:**

Diagnostic error messages are sent to the BM150 display as numeric Alarm Codes, (even if Failure Messages are selected for data transmission the numeric Alarm Code is sent to the display).

```

A l e r t      :
F a i l u r e      # X X X

R R R      N N N

```

X = numeric Alarm Code (see below for the list of Alarm Codes)

R = Device Network Type – MUL=Multidata, SYN=Synchronized, ALN=Alone

N = Device Network Setting – M00=ID-NET Network Master, Sxx= ID-NET Network Slave address, Null string= Alone (no network)

Alarm Code	Description
1	Slave No Reply
64	Slave Address Duplication
171	Protocol Index Failure
185	Backup Memory Communication Failure
187	Wrong Rotary Switch Selection
189	Fieldbus Communication Failure
191	Fieldbus Type Mismatch
193	Fieldbus Configuration Error
195	Fieldbus DHCP Problem
201	No XRF Slave(s) Detected

**Slave Node Alarms (Master only):**

```

A l e r t      : I D - N E T
N o d e # X X      M i s s i n g

R R R      M 0 0

```

X = slave node number (1-31)

R = Device Network Type – MUL=Multidata, SYN=Synchronized

**Network State (Master only):**

```

0      N e t w o r k      1 5
M S S S S S S S S S S S S S S
1 6      N e t w o r k      3 1
S S S S S S S S S S S S S S S

```

M = Master diagnostic condition; S = Slave diagnostic condition:

\* = scanner OK

- =scanner not detected at startup

? =scanner detected at startup but not responding to diagnostic polling

! = scanner diagnostic error

**Standard Reading Results:**

A	A	A	A	A	A	A	A	A	A	A	A	A	A	A	A	A	A	A	A
X	X	X	X	X	X	X	X	X	X	X	X	X	X	X	X	X	X	X	X
X	X	X	X	X	X	X	X	X	X	X	X	X	X	X	X	X	X	X	X
Y	Y	C	o	d	e	s													

A = reading result – Good Read, Partial Read, Multiple Read  
 X = code content  
 Y = number of codes read

**Reading Mask Only (Master Only):**

X	X	X	X	X	X	X	X	X	X	X	X	X	X	X	X	X	X	X	X
G	Y	Y	Y	%	N	Y	Y	Y	%	M	Y	Y	Y	%	P	Y	Y	Y	%
S	S	S	S	S	S	S	S	S	S	S	S	S	S	S	S	S	S	S	S
T	T	T	T	T	T	T	T	T	T	T	T	T	T	T	T	T	T	T	T

X = code content (or "No Read" or "Multiple Read")  
 Y = Good Read, No Read, Multiple Read and Partial Read counters on the last 100 codes read (%)  
 S = Reading Mask for Stand Alone or Master plus Slave readers 1 - 15  
 (0 = No Read, 1 = Good Read, M = Multiple Read)  
 T = Reading Mask for Slave readers 16 - 31  
 (0 = No Read, 1 = Good Read, M = Multiple Read)

**Reading Mask/Device State (Master Only):**

X	X	X	X	X	X	X	X	X	X	X	X	X	X	X	X	X	X	X	X	
P	=	Y	Y	Y	Y	Y	Y	Y	Y		G	R	=	Z	Z	Z	.	Z	Z	%
S	S	S	S	S	S	S	S	S	S	S	S	S	S	S	S	S	S	S	S	S
U	U	U	U	U	U	U	U	U	U	U	U	U	U	U	U	U	U	U	U	U

X = Recognized code label data (or "No Read" or "Multiple Read")  
 Y = Phase Counter (range: 0000000 to 9999999)  
 Z = Good Read or Multiple Read counters (%)  
 S = Reading Mask for Stand Alone or Master plus Slave readers 1 - 15  
 (0 = No Read, 1 = Good Read, M = Multiple Read)  
 U = Diagnostic condition for Stand Alone or Master plus Slave readers 1 - 15:  
 \* = reader OK  
 - = reader not detected at startup  
 ? = reader detected at startup but not responding to diagnostic polling  
 ! = reader diagnostic error

### 7.9.4 BM150 Backup and Restore Procedure

The Backup and Restore functions are valid for any application layout type (point-to-point, network, etc.) using CBX500 connection boxes through the BM100 Backup module (required accessory for BM150 installation).

The Backup and Restore functions are managed through the BM150 display and keypad and therefore are disabled at the BM100 Backup/Restore button.

If it ever becomes necessary to replace the reading device it can be quickly configured through the restore procedure.

BM150 provides complete backup and restore functions (Configuration and Environmental parameters) with the following difference:

For Single Readers or individual ID-NET Slaves:

- Backup and Restore functions provide parameter storage including all configuration jobs present on the reader.

For Master Readers in ID-NET Master/Slave networks:

- Backup and Restore functions provide parameter storage of only the Startup Configuration for the Master and all Slaves present in the network.



**CAUTION:** For Master/Slave networks any other configurations (jobs) stored in the device memory will not be backed up. Therefore upon a restore, all jobs other than the startup configuration will be overwritten (erased). It is strongly recommended to save all configurations to backup files.

**The Slaves must always be configured with the same network baudrate as the Master for correct functioning including performing Backup and Restore procedures.**

Backup and Restore functions cannot be interrupted once started.

To perform **Backup**:

1. Make sure the Write Protection switch on the BM100 is unlocked.
2. Select the **Backup** item from the Extended menu and press the Enter key.
3. When the procedure is complete a message appears on the display showing the results (**Backup OK 1 File Saved** or an error message).
4. Set the Write Protection switch to locked.

To perform **Restore**:

1. Select the **Restore** item from the Extended menu and press the Enter key.
2. When the procedure is complete a message appears on the display showing the results (**Restore OK 1 File Restored** or an error message).

## **8 MAINTENANCE**

---

### **8.1 CLEANING**

Clean the reading window (see Figure A) periodically for continued correct operation of the reader.

Dust, dirt, etc. on the window may alter the reading performance.

Repeat the operation frequently in particularly dirty environments.

Use soft material and alcohol to clean the window and avoid any abrasive substances.

## 9 TROUBLESHOOTING

### 9.1 GENERAL GUIDELINES

- When wiring the device, pay careful attention to the signal name (acronym) on the CBX100/500 spring clamp connectors (chp. 4). If you are connecting directly to the Matrix 210N 25-pin male D-sub connector pay attention to the pin number of the signals (Appendix A).
- If you need information about a certain reader parameter you can refer to the DL.CODE help on line. Connect the device and click on the link to the parameter you're interested.
- If you're unable to fix the problem and you're going to contact your local Datalogic office or Datalogic Partner or ARC, we suggest providing (if possible): Application Program version, Parameter Configuration file, Serial Number and Order Number of your reader. You can get most of this information while DL.CODE is connected to the reader.

TROUBLESHOOTING GUIDE	
Problem	Suggestion
<b>DL.CODE Installation:</b> Autorun or Start.hta doesn't run	<ul style="list-style-type: none"> <li>• Check Windows settings to see if Autorun is disabled.</li> <li>• Associate the file type .hta with the Microsoft HTML Application host <b>mshta.exe</b> in Windows\System32.</li> </ul>
<b>Power ON:</b> the "POWER" LED is not lit.	<ul style="list-style-type: none"> <li>• Is power connected?</li> <li>• If using a power adapter (like PG6000), is it connected to wall outlet?</li> <li>• If using rail power, does rail have power?</li> <li>• If using CBX, does it have power (check switch and LED)?</li> <li>• Check if you are referring to the 25-pin connector or to the CBX spring clamp connectors.</li> <li>• Measure Voltage either at pin <b>13</b> and pin <b>25</b> (for 25-pin connector) or at spring clamp <b>Vdc</b> and <b>GND</b> (for CBX).</li> </ul>
<b>One Shot or Phase Mode using the Input 1 (External Trigger) or Input 2:</b> the "TRIGGER" LED is not blinking while the External Trigger is switching.	<ul style="list-style-type: none"> <li>• Check if you are referring to the 25-pin connector or to the CBX spring clamp connectors.</li> <li>• Is the sensor connected to the Input 1 or Input 2?</li> <li>• Is power supplied to the photo sensor?</li> <li>• For NPN configuration, is power supplied to one of the two I1 or I2 signals (A or B)?</li> <li>• For PNP configuration, is one of the two I1 or I2 signals grounded (A or B)?</li> <li>• Are the photo sensor LEDS (if any) working correctly?</li> <li>• Is the sensor/reflector system aligned (if present)?</li> <li>• On the Reading Phase step check the Input 1 or Input 2 <b>Debounce Filter</b> parameter setting.</li> <li>• On the Reading Phase step check the settings for <b>Acquisition Trigger</b>, <b>Reading Phase-ON</b>, and <b>Reading Phase-OFF</b> parameters.</li> </ul>

TROUBLESHOOTING GUIDE	
Problem	Suggestion
<b>One Shot or Phase Mode using serial trigger source:</b> the "TRIGGER" LED is not blinking.	<ul style="list-style-type: none"> <li>• On the Reading Phase step check the settings for <b>Acquisition Trigger</b>, <b>Reading Phase-ON</b>, and <b>Reading Phase-OFF</b> parameters.</li> <li>• Are the COM port parameters (<b>Baud Rate</b>, <b>Parity</b>, <b>Data Bits</b>, <b>Stop Bits</b>) correctly assigned?</li> <li>• On the Reading Phase step check the settings of <b>Acquisition Trigger String</b>, <b>Reading Phase-ON String</b>, and <b>Reading Phase-OFF String</b> parameters.</li> <li>• Is the serial trigger source correctly connected?</li> </ul>
<b>Phase Mode:</b> the "TRIGGER" LED is correctly blinking but no image is displayed in the DL.CODE window.	<ul style="list-style-type: none"> <li>• Is the Phase frequency lower than the maximum frame rate?</li> </ul>
<b>Continuous Mode:</b> the "TRIGGER" LED is not blinking.	<ul style="list-style-type: none"> <li>• Verify the correct software configuration settings.</li> </ul>
<b>Any Operating Mode:</b> the "TRIGGER" LED is correctly blinking but no result is transmitted by the reader at the end of the reading phase collection.	<ul style="list-style-type: none"> <li>• Check the Code Collection parameters on the Reading Phase step and the Data Formatting parameters on the Data Formatting step.</li> </ul>
<b>Image not clear:</b>	<ul style="list-style-type: none"> <li>• Verify the Focus procedure.</li> </ul>
<b>Image focused but not decoded:</b>	<ul style="list-style-type: none"> <li>• Verify the Image Auto-Setup procedure.</li> </ul>
<b>Reading:</b> the reader always transmits the <b>No Read Message</b>	<ul style="list-style-type: none"> <li>• Run the Rapid Configuration procedure in chapter 1.</li> <li>• Position the reader as described in par. 3.3 and through DL.CODE: <ul style="list-style-type: none"> <li>– Tune the Acquisition Delay on Trigger, if the moving code is out of the reader field of view;</li> <li>– Set the Continuous Operating Mode if no external trigger source is available;</li> <li>– Fine tune the Image Setup to improve the code image quality;</li> <li>– Check the code parameter settings in the Code Setup step: 2D Codes, 1D Codes, and Postal Codes;</li> <li>– View the full resolution code image to check the printing or marking quality.</li> </ul> </li> </ul>
<b>Communication:</b> reader is not transmitting anything to the host.	<ul style="list-style-type: none"> <li>• Is the serial cable wiring correct?</li> <li>• If using CBX, be sure the RS422 termination switch is OFF.</li> <li>• Are the host serial port settings the same as the reader serial port settings?</li> <li>• In DL.CODE Device menu &gt; Settings &gt; Settings &gt; LED Configuration, the COM LED Function can be configured to indicate Main Serial Port TX or Main Serial Port RX.</li> </ul>

<b>TROUBLESHOOTING GUIDE</b>	
<b>Problem</b>	<b>Suggestion</b>
<p><b>Communication:</b> data transferred to the host are incorrect, corrupted or incomplete.</p>	<ul style="list-style-type: none"> <li>• Are the host serial port settings the same as the reader serial port settings?</li> <li>• In the DL.CODE Data Formatting step check the settings of Header and Terminator String parameters.</li> <li>• In the DL.CODE Data Formatting step check the various Message Field parameter settings.</li> </ul>
<p><b>Configuration:</b> cannot access environment parameters in DL.CODE (Device&gt;Settings&gt;Settings menu item is grey)</p>	<ul style="list-style-type: none"> <li>• Are you using the Installer - Expert User level? If not change it in the Options&gt;Change User menu.</li> </ul>
<p><b>How do I obtain my reader Serial Number?</b></p>	<ul style="list-style-type: none"> <li>• The reader Serial Number consists of 9 characters: one letter, 2 numbers, another letter followed by 5 numbers.</li> <li>• The reader Serial Number is printed on a label that is affixed on the case.</li> <li>• The Serial Number is also visible from the DL.CODE Device List Area.</li> </ul>
<p><b>How do I obtain my reader Order Number?</b></p>	<ul style="list-style-type: none"> <li>• The reader Order Number consists of 9 numbers.</li> <li>• The reader Order Number can be obtained by comparing the Device Model (in DL.CODE Device Menu &gt; Settings &gt; Settings &gt; About Device) with the product models page on the Datalogic website.</li> </ul>

## 10 TECHNICAL FEATURES

ELECTRICAL FEATURES	Matrix 210N Serial	Matrix 210N Ethernet	Matrix 210N USB
<b>Power</b> Supply Voltage Consumption	10 to 30 Vdc 0.35 to 0.13 A, 3.9 W max.; 0.16 A @ 24 V	10 to 30 Vdc 0.4 to 0.15 A, 4.5 W max.; 0.18 A @ 24 V	5 Vdc 0.5 A, 2.5 W max
<b>Communication Interfaces</b> Main - RS232 - RS422 full-duplex Auxiliary - RS232 ID-NET Ethernet (Built-in) <sup>7</sup>	2400 to 115200 bit/s 2400 to 115200 bit/s 2400 to 115200 bit/s Up to 1MBaud	2400 to 115200 bit/s 2400 to 115200 bit/s 2400 to 115200 bit/s Up to 1MBaud 10/100 Mbit/s	USB 2.0 up to 921600 bit/s
<b>Inputs:</b> Input 1 (External Trigger) and Input 2 Max. Voltage Max. Input Current	Opto-coupled and polarity insensitive 30 Vdc 10 mA	Opto-coupled and polarity insensitive 30 Vdc 10 mA	
<b>Outputs</b> <sup>8</sup> Output 1 and Output 2 $V_{OUT}$ ( $I_{LOAD} = 0$ mA) Max. $V_{OUT}$ ( $I_{LOAD} = 10$ mA) Max. $P_D = V_{OUT} \times I_{LOAD}$ Max.	Opto-coupled 30 Vdc 1.8 Vdc 170 mW	Opto-coupled 30 Vdc 1.8 Vdc 170 mW	
<b>OPTICAL FEATURES</b>			
Image Sensor	CMOS sensor with Global Shutter		
Image Format	WVGA (752x480)		
Frame Rate	up to 60 frames/sec. @ full window size		
Pitch	± 35°		
Tilt	0° - 360°		
Lighting System	Internal LED Illuminator to EN 62471		
Aiming System	Blue Ring; for liquid lens models only: Laser Pointers IEC 60825-1 2007		
	See chapter 6 for other optical features		
<b>ENVIRONMENTAL FEATURES</b>			
Operating Temperature <sup>9</sup>	0 to 50 °C (32 to 122 °F) for liquid lens models only: 0 to 45 °C (32 to 113 °F)		
Storage Temperature	-20 to 70 °C (-4 to 158 °F)		
Max. Humidity	90% non condensing		
Vibration Resistance EN 60068-2-6	14 mm @ 2 to 10 Hz; 1.5 mm @ 13 to 55 Hz; 2 g @ 70 to 500 Hz; 2 hours on each axis		
Bump Resistance EN 60068-2-29	30g; 6 ms; 5000 shocks on each axis		
Shock Resistance EN 60068-2-27	30g; 11 ms; 3 shocks on each axis		
Protection Class <sup>10</sup> EN 60529	IP65		

<sup>7</sup> for Ethernet models only; supports application protocols: TCP/IP, EtherNet/IP, PROFINET-IO, Modbus TCP

<sup>8</sup> when connected to the CBX connection boxes the electrical features for Output 1 and 2 become the following:  
Opto-isolated;  $V_{CE} = 30$  Vdc max.;  $I_{CE} = 40$  mA continuous max.; 130 mA pulsed max.;  
 $V_{CE}$  saturation = 1 Vdc max. @ 10 mA;  $P_D = 90$  mW Max. @ 50 °C ambient temp.

<sup>9</sup> high ambient temperature applications should use metal mounting bracket for heat dissipation.

<sup>10</sup> IP54 for ESD models



<b>PHYSICAL FEATURES</b>		<b>M210N straight (0°)</b>	<b>M210N (90°)</b>	<b>M210N LQL</b>
Dimensions		50 x 25 x 45 mm (2 x 1 x 1.8 in)	54 x 32 x 45 mm (2.1 x 1.3 x 1.8 in)	61 x 25 x 45 mm (2.4 x 1 x 1.8 in)
Weight (with cable)		204 g. (7.2 oz.)	190 g. (6.7 oz.)	237 g. (8.4 oz.)
Material		ZAMA	Aluminium	ZAMA / Nickel finish
<b>SOFTWARE FEATURES</b>				
<b>Readable Code Symbologies</b>				
<b>1-D and stacked</b>		<b>2-D</b>		<b>POSTAL</b>
<ul style="list-style-type: none"> <li>• PDF417 Standard and Micro PDF417</li> <li>• Code 128 (GS1-128)</li> <li>• Code 39 (Standard and Full ASCII)</li> <li>• Code 32</li> <li>• MSI</li> <li>• Standard 2 of 5</li> <li>• Matrix 2 of 5</li> <li>• Interleaved 2 of 5</li> <li>• Codabar</li> <li>• Code 93</li> <li>• Pharmacode</li> <li>• EAN-8/13 - UPC-A/E (including Addon 2 and Addon 5)</li> <li>• GS1 DataBar Family</li> <li>• Composite Symbologies</li> </ul>		<ul style="list-style-type: none"> <li>• Data Matrix ECC 200 (Standard, GS1 and Direct Marking)</li> <li>• QR Code (Standard and Direct Marking)</li> <li>• Micro QR Code</li> <li>• MAXICODE</li> <li>• Aztec Code</li> </ul>		<ul style="list-style-type: none"> <li>• Australia Post</li> <li>• Royal Mail 4 State Customer</li> <li>• Kix Code</li> <li>• Japan Post</li> <li>• PLANET</li> <li>• POSTNET</li> <li>• POSTNET (+BB)</li> <li>• Intelligent Mail</li> <li>• Swedish Post</li> </ul>
<b>Operating Mode</b>		CONTINUOUS, ONE SHOT, PHASE MODE		
<b>Configuration Methods</b>		<ul style="list-style-type: none"> <li>• X-PRESS Human Machine Interface</li> <li>• Windows-based SW (DL.CODE) via Ethernet or Serial Interface</li> <li>• Host Mode Programming sequences sent over Serial or Ethernet TCP interfaces</li> </ul>		
<b>Parameter Storage</b>		Permanent memory (Flash)		
<b>CODE QUALITY METRICS</b>				
<b>Standard</b>		<b>Supported Symbologies</b>		
ISO/IEC 16022		Data Matrix ECC 200		
ISO/IEC 18004		QR Code		
AIM DPM		Data Matrix ECC 200, QR Code		
ISO/IEC 15416		Code 128, Code 39, Interleaved 2 of 5, Codabar, Code 93, EAN-8/13, UPC-A/E		
<b>USER INTERFACE</b>				
LED Indicators	Power, Ready, Good, Trigger, Com, Status, (Ethernet Network), (Green Spot)			
Keypad Button	Configurable via DL.CODE			
Beeper	Configurable via DL.CODE			

## A ALTERNATIVE CONNECTIONS

The connector pinouts and notes given in this appendix are for custom cabling applications.

### POWER COM AND I/O CONNECTOR

The Matrix 210N reader is equipped with a 25-pin male D-sub connector for connection to the power supply, serial interfaces and input/output signals. The details of the connector pins are indicated in the following table:

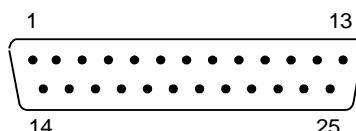

Figure 90 - 25-pin Male D-sub Connector

Power, COM and I/O Connector Pinout			
Pin	Name	Function	
13, 9	Vdc	Power supply input voltage +	
25, 7	GND	Power supply input voltage -	
1	CHASSIS	Cable shield connected to chassis	
18	I1A	External Trigger A (polarity insensitive)	
19	I1B	External Trigger B (polarity insensitive)	
6	I2A	Input 2 A (polarity insensitive)	
10	I2B	Input 2 B (polarity insensitive)	
8	O1+	Output 1 +	
22	O1-	Output 1 -	
11	O2+	Output 2 +	
12	O2-	Output 2 -	
20	RX	Auxiliary RS232 RX	
21	TX	Auxiliary RS232 TX	
23	ID+	ID-NET network +	
24	ID-	ID-NET network -	
14, 15, 16, 17	NC	Not Connected	
Pin	Name	RS232	RS422 Full-Duplex
2	MAIN INTERFACE (SW SELECTABLE)	TX	TX+
3		RX	*RX+
4		-	TX-
5		-	*RX-

\* Do not leave floating, see par. 4.2.2 for connection details.

In order to meet EMC requirements:

- connect the reader chassis to the plant earth ground by means of a flat copper braid shorter than 100 mm;
- for direct connections, connect the main interface cable shield to pin 1 of the 25-pin connector.

## ON-BOARD ETHERNET CONNECTOR

A Standard M12 D-Coded connector is provided for the on-board Ethernet connection. This interface is IEEE 802.3 10 BaseT and IEEE 802.3u 100 BaseTx compliant.

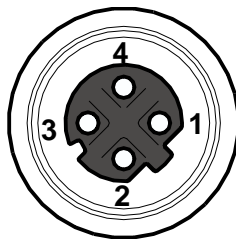

Figure 91 - M12 D-Coded Female Ethernet Network Connector

On-Board Ethernet Network Connector Pinout		
Pin	Name	Function
1	TX +	Transmitted data (+)
2	RX +	Received data (+)
3	TX -	Transmitted data (-)
4	RX -	Received data (-)

## ID-NET NETWORK TERMINATION

The network must be properly terminated by a 120 Ohm resistor at the first and last reader of the network.

## INPUTS

There are two opto-coupled polarity insensitive inputs available on the 25-pin connector of the reader: Input 1 (External Trigger) and Input 2, a generic input. See par. 4.5 for more details.

The electrical features of both inputs are:

$$V_{AB} = 30 \text{ Vdc max.}$$

$$I_{IN} = 10 \text{ mA max.}$$

The relative pins on the 25-pin connector are:

Pin	Name	Function
9	Vdc	Power Supply input voltage +
18	I1A	External Trigger A (polarity insensitive)
19	I1B	External Trigger B (polarity insensitive)
6	I2A	Input 2 A (polarity insensitive)
10	I2B	Input 2 B (polarity insensitive)
7	GND	Power Supply input voltage -

## OUTPUTS

Two opto-coupled general purpose outputs are available on the 25-pin connector. See par. 4.6 for more details.

The pinout is the following:

Pin	Name	Function
9	Vdc	Power Supply input voltage +
8	O1+	Configurable digital output 1 - positive pin
22	O1-	Configurable digital output 1 - negative pin
11	O2+	Configurable digital output 2 - positive pin
12	O2-	Configurable digital output 2 - negative pin
7	GND	Power Supply input voltage -

The electrical features of the two outputs are the following:

$$V_{\text{Out}} (I_{\text{Load}} = 0 \text{ mA}) \text{ max} = 30 \text{ Vdc.}$$

$$V_{\text{Out}} (I_{\text{Load}} = 10 \text{ mA}) \text{ max} = 1.8 \text{ Vdc}$$

$$I_{\text{Load}} \text{ max} = 40 \text{ mA continuous; } 130 \text{ mA pulsed}$$

$$P_{\text{D}} = V_{\text{Out}} \times I_{\text{Load}} \text{ max} = 170 \text{ mW}$$

The output signals are fully programmable being determined by the configured Activation/Deactivation events, Deactivation Timeout or a combination of the two. For further details refer to the Help On Line page for the Output Setup step in DL.CODE.

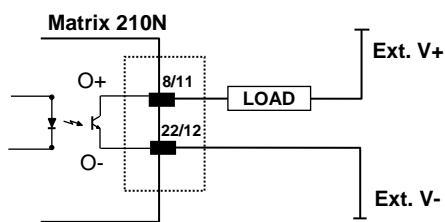

Figure 92 – Isolated Current Sinking Output Connection

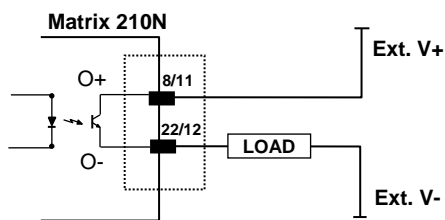

Figure 93 – Isolated Current Sourcing Output Connection

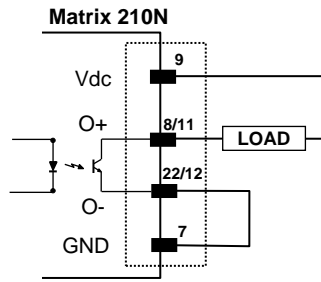

Figure 94 – Non-Isolated Current Sinking Output Connection

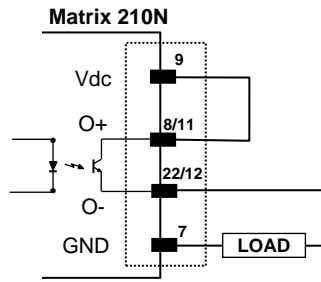
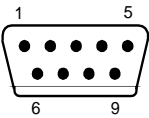
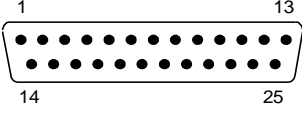

Figure 95 – Non-Isolated Current Sourcing Output Connection

## USER INTERFACE – SERIAL HOST

RS232 PC-side connections			
 <p>9-pin male connector</p>		 <p>25-pin male connector</p>	
Pin	Name	Pin	Name
2	RX	3	RX
3	TX	2	TX
5	GND	7	GND

### How To Build A Simple Interface Test Cable:

The following wiring diagram shows a simple test cable including power, external (push-button) trigger and PC RS232 COM port connections.

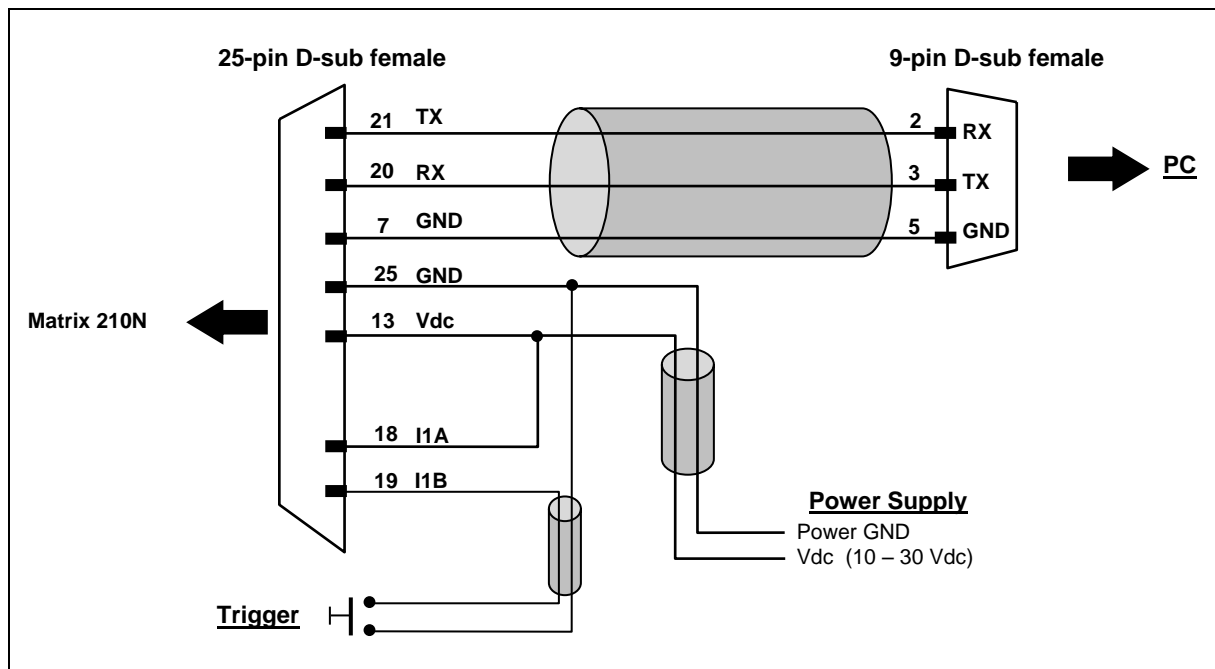

Figure 96- Test Cable for Matrix 210N

# GLOSSARY

---

## **AIM**

(Association for Automatic Identification and Mobility): AIM Global is the international trade association representing automatic identification and mobility technology solution providers.

## **AIM DPM Quality Guideline**

Standard applicable to the symbol quality assessment of direct part marking (DPM) performed in using two-dimensional bar code symbols. It defines modifications to the measurement and grading of several symbol quality parameters.

## **Barcodes (1D Codes)**

A pattern of variable-width bars and spaces which represents numeric or alphanumeric data in machine-readable form. The general format of a barcode symbol consists of a leading margin, start character, data or message character, check character (if any), stop character, and trailing margin. Within this framework, each recognizable symbology uses its own unique format.

## **BIOS**

Basic Input Output System. A collection of ROM-based code with a standard API used to interface with standard PC hardware.

## **Bit**

Binary digit. One bit is the basic unit of binary information. Generally, eight consecutive bits compose one byte of data. The pattern of 0 and 1 values within the byte determines its meaning.

## **Bits per Second (bps)**

Number of bits transmitted or received per second.

## **Byte**

On an addressable boundary, eight adjacent binary digits (0 and 1) combined in a pattern to represent a specific character or numeric value. Bits are numbered from the right, 0 through 7, with bit 0 the low-order bit. One byte in memory can be used to store one ASCII character.

## **Composite Symbologies**

Consist of a linear component, which encodes the item's primary data, and an adjacent 2D composite component, which encodes supplementary data to the linear component.

## **Dark Field Illumination**

Lighting of surfaces at low angles used to avoid direct reflection of the light in the reader's lens.

## **Decode**

To recognize a barcode symbology (e.g., Codabar, Code 128, Code 3 of 9, UPC/EAN, etc.) and analyze the content of the barcode scanned.

**Depth of Field**

The difference between the minimum and the maximum distance of the object in the field of view that appears to be in focus.

**Diffused Illumination**

Distributed soft lighting from a wide variety of angles used to eliminate shadows and direct reflection effects from highly reflective surfaces.

**Direct Part Mark (DPM)**

A symbol marked on an object using specific techniques like dot peening, laser etching, chemical etching, etc.

**EEPROM**

Electrically Erasable Programmable Read-Only Memory. An on-board non-volatile memory chip.

**Element**

The basic unit of data encoding in a 1D or 2D symbol. A single bar, space, cell, dot.

**Exposure Time**

For digital cameras based on image sensors equipped with an electronic shutter, it defines the time during which the image will be exposed to the sensor to be acquired.

**Flash**

Non-volatile memory for storing application and configuration files.

**Host**

A computer that serves other terminals in a network, providing services such as network control, database access, special programs, supervisory programs, or programming languages.

**Image Processing**

Any form of information processing for which the input is an image and the output is for instance a set of features of the image.

**Image Resolution**

The number of rows and columns of pixels in an image. The total number of pixels of an image sensor.

**Image Sensor**

Device converting a visual image to an electric signal. It is usually an array of CCD (Charge Coupled Devices) or CMOS (Complementary Metal Oxide Semiconductor) pixel sensors.

**IEC**

(International Electrotechnical Commission): Global organization that publishes international standards for electrical, electronic, and other technologies.

**IP Address**

The terminal's network address. Networks use IP addresses to determine where to send data that is being transmitted over a network. An IP address is a 32-bit number referred to as a series of 8-bit numbers in decimal dot notation (e.g., 130.24.34.03). The highest 8-bit number you can use is 254.



**ISO**

(International Organization for Standardization): A network of the national standards institutes of several countries producing world-wide industrial and commercial standards.

**LED (Light Emitting Diode)**

A low power electronic light source commonly used as an indicator light. It uses less power than an incandescent light bulb but more than a Liquid Crystal Display (LCD).

**LED Illuminator**

LED technology used as an extended lighting source in which extra optics added to the chip allow it to emit a complex radiated light pattern.

**Matrix Symbologies (2D Codes)**

An arrangement of regular polygon shaped cells where the center-to-center distance of adjacent elements is uniform. Matrix symbols may include recognition patterns which do not follow the same rules as the other elements within the symbol.

**Multi-row (or Stacked) Symbologies**

Symbologies where a long symbol is broken into sections and stacked one upon another similar to sentences in a paragraph.

**RAM**

Random Access Memory. Data in RAM can be accessed in random order, and quickly written and read.

**Symbol Verification**

The act of processing a code to determine whether or not it meets specific requirements.

**Transmission Control Protocol/Internet Protocol (TCP/IP)**

A suite of standard network protocols that were originally used in UNIX environments but are now used in many others. The TCP governs sequenced data; the IP governs packet forwarding. TCP/IP is the primary protocol that defines the Internet.

# INDEX

---

## A

Accessories, 51  
Alternative Connections, 150  
Application Examples, 52  
Auto Calibration, 98  
Auxiliary RS232 Interface, 71

## B

Backup and Restore, 131

## C

CBX Electrical Connections, 62  
Compliance, vii

## D

Diagnostic Alarms, 136  
Diagnostic Indication, 49  
Direct Part Marking Applications, 109

## E

Ethernet Connection, 81  
External Lighting Systems, 54

## F

Fieldbus Connection, 84  
FOV Calculation, 92

## G

General View, xi  
Glossary, 155

## H

Handling, ix

## I

ID-NET Cables, 66  
ID-NET Interface, 66  
ID-NET Multidata Network, 86  
ID-NET Network Termination, 67, 151  
ID-NET Response Time, 67  
ID-NET Synchronized Network, 87  
Inputs, 72, 151  
Internal Network Configurations, 115

## L

Layouts, 81

## M

Main Serial Interface, 63  
Maintenance, 144  
Manual Calibration, 99  
Mechanical Dimensions, 56  
Model Description, 50  
Mounting and Positioning Matrix 210N, 59  
Multi Image Acquisition Settings, 102  
Multidata ID-NET Network Configurations, 119

## O

On-Board Ethernet Connector, 151  
On-Board Ethernet Interface, 80  
Outputs, 77, 152

## P

Package Contents, 55  
Pass-through, 85  
Pass-through Configurations, 114  
Patents, vi  
Power Com and I/O Connector, 150  
Power Supply, vii, 63

## R

Rapid Configuration, 1  
Reader Configuration, 97  
Reading Features, 91  
References, vi  
Restore Defaults, 134  
RS232 Interface, 64  
RS422 Full-Duplex, 65

## S

Serial Connection, 83  
Software Configuration, 97  
Statistics, 137  
Support Through The Website, vi  
Synchronized ID-NET Network Configurations,  
124

## T

Technical Features, 148  
Troubleshooting, 145



 **DATALOGIC**

---

[www.datalogic.com](http://www.datalogic.com)